

# **COMBINATORY REDUCTION SYSTEMS**

# COMBINATORY REDUCTION SYSTEMS

PROEFSCHRIFT

TER VERKRIJGING VAN DE GRAAD VAN  
DOCTOR IN DE WISKUNDE EN NATUURWETENSCHAPPEN  
AAN DE RIJKSUNIVERSITEIT TE UTRECHT,  
OP GEZAG VAN DE RECTOR MAGNIFICUS  
PROF. DR. A. VERHOEFF,  
VOLGENS BESLUIT VAN HET COLLEGE VAN DECANEN  
IN HET OPENBAAR TE VERDEDIGEN  
OP WOENSDAG 11 JUNI 1980 DES NAMIDDAGS TE 2.45 UUR

DOOR

**JAN WILLEM KLOP**

GEBOREN OP 19 DECEMBER 1945

TE GORINCHEM

1980

MATHEMATISCH CENTRUM, AMSTERDAM

PROMOTOR: PROF.DR. D. VAN DALEN

Dit proefschrift kwam tot stand mede onder leiding van Dr. H.P. BARENDRECT.

*voor mijn ouders  
voor Marianne en Maartje*



CONTENTS

1

CONTENTS	1
ACKNOWLEDGEMENTS	iii
INTRODUCTION AND SUMMARY	v
INTERDEPENDENCE OF THE SECTIONS	xiii
CHAPTER I. $\lambda\beta$ -CALCULUS AND DEFINABLE EXTENSIONS	1
1. Lambda terms	1
2. Combinators	11
3. Labels and descendants	17
4. Finite Developments	30
5. Abstract Reduction Systems	44
6. The Church-Rosser Theorem	57
7. Church's Theorem	72
8. Strong Normalization of labeled $\lambda$ -calculi (via $\lambda I$ -calculus)	75
9. Standardization	84
10. Standardization and equivalence of reductions	93
11. Normalization	113
12. Cofinal reductions	115
CHAPTER II. REGULAR COMBINATORY REDUCTION SYSTEMS	119
1. Combinatory Reduction Systems	120
2. Descendants and labels for combinatory reductions	137
3. The Church-Rosser Theorem for regular combinatory reductions	141
4. Reductions with memory	151
5. Non-erasing reductions	164
6. Decreasing labelings and Strong Normalization	175
CHAPTER III. IRREGULAR COMBINATORY REDUCTION SYSTEMS	195
1. Counterexamples to the Church-Rosser property	195
2. Intermezzo. An intuitive explanation via Böhm trees	216
3. Additional properties of $\lambda(\text{CL}) \oplus \mathcal{D}_h, \mathcal{D}_s, \mathcal{D}_k, \text{SP}$	220
4. Some positive CR-results for non-left-linear CRS's	232
5. The 'black box' lemma	240

CHAPTER IV. $\lambda\beta\eta$ -CALCULUS	249
1. The Church-Rosser Theorem for $\lambda\beta\eta$ -calculus	249
2. Residuals	252
3. Tracing in diagrams	257
4. Standardization of $\beta\eta$ -reductions	263
5. The Normalization Theorem for $\lambda\beta\eta$ -calculus	279
6. Cofinal $\beta\eta$ -reductions	293
REFERENCES	298
LIST OF NOTATIONS	304
INDEX	313
SAMENVATTING	318
CURRICULUM VITAE	323

## ACKNOWLEDGEMENTS

This thesis was written while I was employed half by the Mathematical Institute and half by the 'Centrale Interfaculteit' of the University of Utrecht, from 1975 to 1979. It was a privilege to be a promovendus in the Logic department of Professor Dirk van Dalen, and those years will remain a dear memory because of the enjoyable and stimulating working conditions he created there. Apart from that, it is my pleasure to express my deep gratitude to him for the general guidance of my work and for the numerous detailed improvements that he suggested in an earlier draft of the text.

Henk Barendregt ~~taught~~ me the subject of this thesis and supervised its development. I am very grateful to him for the close co-operation that we often had, and for his admirable enthusiasm. At almost every moment, day or night, he was willing to discuss  $\lambda$ -calculus and to listen to my proofs, including a sequence of false ones. I owe him a great debt.

In my pre-doctoral year ('74-'75) Henk Barendregt, Jan Bergstra (now at the University of Leiden), Henri Volken (then at the E.T.H. Zürich) and I had a research-seminar on  $\lambda$ -calculus which was of special value to me, since it provided a basis for the present work and since it was my first encounter with mathematical research. I want to thank my fellow-members of this seminar, and Jan Bergstra moreover for some joint work afterwards which is related to this thesis.

I also want to thank my ' $\lambda$ -calculus colleagues' Roger Hindley, Jean-Jacques Lévy and Gerd Mitschke, for several useful discussions and encouraging correspondence; and Jeff Zucker and David Isles for their stimulating interest. And my room-mate at the Mathematical Institute, Albert Visser, for numerous discussions on (e.g.)  $\lambda$ -calculus.

I am very grateful to Professor Baayen who accepted this thesis for publication as EMC Tract, and to Mr. Barning and Mr. Zwarst of the Mathematical Centre in Amsterdam; the latter for the multiplication of this thesis. I am especially thankful to Mrs. Ria Riechelmann who typed the whole manuscript with impressive speed and skill.

Finally, I thank my wife Marianne (even though she does not want it); without her the work on this thesis would neither have been started nor have been finished.





## INTRODUCTION AND SUMMARY

*Title of this thesis.* In the present work we are exclusively concerned with the study of syntactical properties of  $\lambda$ -calculus ( $\lambda$ , for short), Combinatory Logic (CL), Recursive Program Schemes, and in general, Term Rewriting Systems with bound variables; especially those syntactical properties which concern *reductions*. Hence the title of this thesis; Combinatory Reduction Systems (CRS's) is the name by which we refer to Term Rewriting Systems plus bound variables. The word 'combinatory' seems justified to us since it captures the essential feature of these reduction systems: subterms in a CRS-term are manipulated in a 'combinatory way'.

*Motivation.* There is ample motivation for the (in our case syntactical) investigation of CRS's. The importance of the paradigms of CRS's,  $\lambda$  and CL, is well-known in Mathematical Logic (see also our historical remarks below). Moreover,  $\lambda$  and CL play an important role in the semantics of programming languages; we refer to the work of Scott. One can consider  $\lambda$ -calculus as the prototype of a programming language; see MORRIS [68]. Furthermore, in theoretical Computer Science, certain simple CRS's, Recursive Program Schemes, and more general, CRS's without substitution known as Term Rewriting Systems are studied. Then there is the AUTOMATH-project of de Bruijn, at the borderline of Computer Science and Foundations of Mathematics, which has as one of its aims the computer verification of mathematical proofs. Here  $\lambda$ -calculus plays an important role, too; we refer to the recent work of VAN DAALEN [80].

In Proof Theory one is often interested in certain extensions of (typed)  $\lambda$ -calculus, such as  $\lambda^T$   $\oplus$  recursor  $R$ , iterator  $J$ , Pairing operators, etc. All these extensions are covered by the concept of a CRS. It is interesting that one encounters in Proof Theory also CRS's which have a variable-binding mechanism other than the usual one in  $\lambda$ -calculus: namely, in the normalization of Natural Deduction proofs. Finally, let us mention that there are recent foundational studies by Feferman in which certain syntactical properties of extensions of  $\lambda$ -calculus are relevant.

We conclude that CRS's arise in a variety of fields and that the study of their syntactical properties is worth-while.

*Restriction to syntax.* Our restriction to syntactical investigations, as opposed to semantical considerations, is born solely from limitation and is not by principle. Recently, D. Scott, G. Plotkin and others have originated a model theory for the  $\lambda$ -calculus and extensions thereof; by means of this one can obtain in a fast and elegant way some results which require much labour in a syntactical treatment. E.g. the consistency of  $\lambda\eta \oplus$  Surjective Pairing.

We do not feel however that the availability of the powerful modeltheoretic methods lessens the usefulness of Church-Rosser proofs and related syntactical theorems. The reason is the well-known fact that the (sometimes) tedious work of syntactical investigations yields longer proofs, but also more information. We mention a typical example above: model theory yields a beautiful proof of the consistency of  $\lambda\eta \oplus$  S.P., but the much longer proof which will appear in DE VRIJER [80] yields not only consistency, but also conservativity of  $\lambda\eta \oplus$  S.P. over  $\lambda\eta$ . (Another reason is that the models of Plotkin and Scott, only bear on extensions of  $\lambda$ -calculus and not on several other Combinatory Reduction Systems.)

Although we have occasionally allowed ourselves a digression for completeness sake, this thesis certainly does not aim to give a survey of the syntax of  $\lambda$ -calculus and extensions. For such a survey we refer to Barendregt's forthcoming monograph '*The lambda calculus, its syntax and semantics*'.

*Some history.* We will now give a short sketch of the history of the subject; for a more extensive historical introduction we refer to the introduction in BARENDREGT [80], to the short historical survey in SCOTT [79] and to the many historical comments in CURRY-FEYS [58].

Combinatory Logic starts in 1924 with SCHÖNFINKEL [24]: '*Über die Bausteine der Mathematischen Logik*'. Schönfinkel tries to reduce the number of primitive concepts in (higher order predicate) logic; in particular, his aim is to eliminate bound variables. His motivation: asserting e.g. that  $\forall p, q \neg p \vee (p \vee q)$  for propositions, does not say anything about  $p, q$  but only about  $\neg$  and  $\vee$ . To obtain his aim he introduces '*combinators*'  $I, K, S, B, C$ , '*defined*' by  $Ix = x$ ,  $Kxy = x$ ,  $Sxyz = xz(yz)$ ,  $Cxyz = xzy$  and  $Bxyz = x(yz)$ . ( $S$  and  $K$  alone are sufficient, as Schönfinkel remarks.) Schönfinkel then proves in an informal way that every formula  $A(x_1, \dots, x_n)$ , with free variables  $\subseteq \{x_1, \dots, x_n\}$ , in higher order predicate logic (where quantification over predicates and over predicates of predicates, and so on, is allowed)

can be rewritten as a term  $Mx_1 \dots x_n$  where  $M$  is built by application from the combinators and an 'incompatibility predicate'  $U$  defined by  $UPQ \equiv \forall x (\neg P(x) \vee \neg Q(x))$ .

*Example:* Let  $P(g,y,f)$  be the formula  $\forall x \neg (fx \wedge gxy)$ . Then  $P(g,y,f) = UF(Cgy) = CU(Cgy)f = \beta CU(Cg)yf = \beta(\beta(CU))Cgyf$ . Hence every closed formula  $A$  can be rewritten as a term  $M$  built from combinators and  $U$ ; it can even be written as a term  $NU$  where  $N$  contains only combinators (not  $U$ ). So, omitting  $U$ , every sentence in Schönfinkel's higher order predicate logic can be represented by a term built from the basic combinators alone.

Around 1928 the combinators were rediscovered by H.B. Curry, who tried by means of a 'Combinatory Logic' to investigate the foundations of mathematics. The aim of Curry's program is to use CL to give an *analysis of substitution and the use of variables*; and to attack the paradoxes like the one of Russell. CL in Curry's program is also referred to as *Illative Combinatory Logic*, where the word 'illative' denotes the presence of inference rules as in predicate logic. Curry's program does meet certain obstacles; Schönfinkel's naive system was inconsistent (as demonstrated by 'Curry's paradox'), and some later proposed alternative systems also suffered from inconsistency. The foundational claims of Curry's program are not undisputed, cf. SCOTT [79].

With a different motivation, a variant of CL was developed at about the time of Curry's rediscovery of CL, namely ' $\lambda$ -calculus', by Church, Kleene, Rosser. Kleene was led by the study of  $\lambda$ -terms to his First Recursion Theorem and other fundamental recursion theoretic results;  $\lambda$ -definability of functions was studied and discovered to be equivalent to various other definitions of 'effective computable' functions (e.g. the one via Turing machines). (See Kleene's eye-witness account of this period in CROSLY [75].) Rosser demonstrated the close connection between  $\lambda$ -calculus and CL, and established, together with Church, the consistency of  $\lambda$ -calculus and CL by a syntactical argument. (The Church-Rosser Theorem for  $\lambda$ -calculus and CL.)

The Church-Rosser theorem yields the existence of *term models* of  $\lambda$ -calculus and CL. Term models of several versions of  $\lambda$  and CL were studied in BARENDREGT [71]. In the last ten years there has been a break-through in the 'model theory' of  $\lambda$ -calculus and CL, starting with the models  $D_\infty$  and  $P_\omega$  of Scott and Plotkin. These models are of great importance in the semantics

of programming languages.

*Main results.* As the main results of this thesis we consider

- (I) the introduction of the concept CRS and the development of the basic syntactical theorems for CRS's; notably the Church-Rosser theorem (CR), the Lemma of Parallel Moves (PM) and the theorem of Finite Developments (FD), and
- (II) simultaneously, the generalization of a method due to R. Nederpelt which enables one to reduce Strong Normalization proofs for certain CRS's to Weak Normalization proofs. This device is not only interesting in itself, but enabled us also to obtain the theorems FD, CR, etc.;
- (III) the negative result that CR fails for certain non-left-linear CRS's, e.g.

$\lambda(n) \oplus$  Surjective Pairing  $\not\models$  CR

$\lambda, \text{CL} \oplus$  DMM  $\rightarrow$  M  $\not\models$  CR

$\lambda \oplus \left\{ \begin{array}{l} \text{if } \tau \text{ then } X \text{ else } Y \rightarrow X \\ \text{if } \perp \text{ then } X \text{ else } Y \rightarrow Y \\ \text{if } Z \text{ then } X \text{ else } X \rightarrow X \end{array} \right\} \not\models$  CR,

on the other hand, the positive result that e.g.

$\text{CL} \oplus \mathcal{D}(M, M) \rightarrow M \models$  CR

$\text{CL} \oplus$  if-then-else- as above  $\models$  CR.

(In the positive result, CL can be replaced by an arbitrary non-ambiguous and left-linear TRS; not so in the negative one.)

*Summary.* The first part of Chapter I ( $\lambda\beta$ -calculus and definable extensions, which include Recursive Program Schemes) is mainly devoted to the basic syntactical theorems of  $\lambda$ -calculus: the Lemma of Parallel Moves, the Theorem of Finite Developments and as a consequence, the Church-Rosser Theorem. In the proofs of these well-known theorems we make a systematic use of *labels*, and of *reduction diagrams*. Since it is convenient for some applications later on, as well as interesting for its own sake, we not only prove the fore-mentioned theorems for  $\lambda\beta$ -calculus but for a wider class of 'reduction systems', which we have called *definable extensions* of  $\lambda\beta$ -calculus. The results also hold for *substructures* of such extensions; e.g. Combinatory Logic is a substructure of a definable extension of  $\lambda\beta$ -calculus.

The method of proof of 'Finite Developments' was first used in BARENDREGT, BERGSTRA, KLOP, VOLKEN [76]; it lends itself easily to prove FD for other extensions of  $\lambda$ -calculus (see also BARENDREGT [80]). The use of

reduction diagrams is new; it was independently proposed in HINDLEY [78"]. The treatment via reduction diagrams is only a slight refinement of that in LÉVY [78]; it pays off especially in Chapter IV, where  $\lambda\beta\eta$ -calculus is considered.

Before proving the Church-Rosser theorem, we have collected in section I.5 several facts, mostly well-known, which hold for 'Abstract Reduction Systems' and which we need later on. Typical examples are the Lemma of Hindley-Rosen and (as we call it) Newman's Lemma. Also a preparation is made for a part of Chapter II, in the form of Nederpelt's Lemma and related propositions.

In I.7 we proceed to prove another classical  $\lambda$ -calculus theorem, which we have called 'Church's Theorem'. It plays a key role in a new proof (in I.8) of Strong Normalization for typed  $\lambda$ -calculus and some more general labeled  $\lambda$ -calculi, such as 'Lévy's  $\lambda$ -calculus'. Again the theorem is proved not only for  $\lambda I$ -calculus, but for 'definable extensions of  $\lambda I$ '.

Sections I.9 - I.10 contain two new proofs of the well-known Standardization Theorem. Compared to the known proofs (see e.g. MITSCHKE [79]) these new proofs yield a simpler algorithm to standardize a reduction. The first proof is used in Chapter IV to obtain as a new result standardization for  $\beta\eta$ -reductions, and the second proof is used at the end of Chapter II to obtain Standardization for some generalizations of the reduction systems in Chapter I (e.g. for  $\lambda \oplus$  recursor  $R$ , if one uses the 'left-normal' version of  $R$ ). Of all these results the strong versions are proved, in the sense of (Lévy-) equivalence  $\simeq_L$  of reductions. (E.g. for every finite reduction  $R$ , there is a unique standard reduction  $R_{st}$  which is equivalent to  $R$ . This strong version of the Standardization Theorem is due to J.J. Lévy.) Our second proof of the Standardization Theorem casts some light on the relation between standard reductions and equivalence of reductions. As a digression, using the concept 'meta-reduction' of reductions as in this second proof, we prove in I.10 some facts about equivalence classes of finite reductions. (E.g. in  $\lambda I$  the cardinality of the equivalence class  $\{R' \mid R' \simeq_L R\}$  can be any  $n \geq 1$ , but not be infinite.)

Chapter I is concluded by deriving in I.11 the well-known Normalization Theorem for  $\lambda\beta$  (and definable extensions thereof) and by considering in I.12 'cofinal' reductions; the main theorem about such reductions was proved independently by S. Micali and M. O'Donnell.

Chapter II introduces a very general kind of reduction systems, ranging from Term Rewriting Systems in Computer Science to Normalization procedures in Proof Theory. These reduction systems can be called 'Term Rewriting Systems with bound variables'; we refer to them as *Combinatory Reduction Systems*. In Chapter II we pose a severe restriction on such reduction systems: they have to satisfy the well-known conditions of being '*non-ambiguous and left-linear*', a phrase which we will abbreviate by '*regular*'. For such CRS's we have proved in Chapter II the main syntactical theorems, such as the ones mentioned above in the summary of Chapter I. (Normalization and Standardization only for a restricted class of regular CRS's, though.) Since the behaviour w.r.t. substitution of CRS's can be arbitrarily complicated (as contrasted to that of  $\lambda\beta$ ), it turned out to be non-trivial to prove the theorem of Finite Developments, a Strong Normalization result. This obstacle is overcome by a device of Nederpelt for the reduction of SN-proofs for regular CRS's to WN-proofs. Not only for that reason, but also since this method seems to have independent merits, we have generalized Nederpelt's method to the class of all regular CRS's. This is done by introducing '*reductions with memory*'; nothing is 'thrown away' in such reductions; they are *non-erasing*, like  $\lambda I$ -calculus is. In II.5 we generalize Church's Theorem for  $\lambda I$  to all regular non-erasing CRS's. Section II.6 contains a generalization of the Strong Normalization theorem for  $\lambda^L, \lambda^T, \lambda^{HW}$  in Chapter I.8, to regular CRS's for which a '*decreasing labeling*' can be found (like the types in a typed  $\lambda$ -calculus are decreasing labels). This generalization enables us in turn to extend Lévy's method of labeling to all regular CRS's, and to prove the corresponding SN-result (this is only executed for TRS's, i.e. CRS's without substitution, though). As a corollary we obtain Standardization and Normalization for some '*left-normal*' regular CRS's.

Whereas in Chapter I and II we considered only regular CRS's, we deal in Chapter III with some irregular ones, namely with some non-left-linear CRS's; i.e. in a reduction rule some metavariable in the LHS of a reduction rule occurs twice, as in  $\lambda XX \rightarrow X$ . (Except for the case of 'Surjective Pairing' we do not consider *ambiguous* rules; for results about ambiguous TRS's we refer to HUET [78] and HUET-OPPEN [80].)

Non-left-linearity (we will omit the word 'left' sometimes) of the reduction rules turns out to be an obstacle to the CR-property: *in a non-linear CRS which is 'strong enough', the CR-property fails*. This is proved for some non-linear extensions of  $\lambda$ -calculus (or Combinatory Logic), thus

answering some questions of C. Mann, R. Hindley and J. Staples negatively. Although the intuition behind these CR-counterexamples is easily grasped, the proof that they are indeed so requires several technicalities. In an Intermezzo we expand this intuition using the well-known 'Böhm-trees', a kind of infinite normal forms for terms.

In III.3 we have considered for these non-linear systems for which CR fails, other properties (which are otherwise corollaries of CR) such as Unicity of Normal forms (UN), Consistency, etc. Even though CR fails, UN does hold for the systems considered.

In III.4,5 we prove CR for some restricted classes of non-linear CRS's. Most notable is a positive answer to a question suggested in O'DONNELL [77] : Does CR hold when the non-linear trio of rules (\*)

if true then X else Y  $\rightarrow$  X

if false then X else Y  $\rightarrow$  Y

if X then Y else Y  $\rightarrow$  Y

is added to a regular TRS?

This is seemingly in contradiction with our earlier CR-counterexample for  $CL \oplus B$  where  $B$  is a constant representing the branching operation above, having the rules

$B\lambda XY \rightarrow X$ ,  $B\lambda XY \rightarrow Y$ ,  $B\lambda XY \rightarrow Y$ .

The explanation is that  $CL \oplus B \not\models CR$ , but  $CL \oplus B(-,-,-) \models CR$ , where the notation  $B(-,-,-)$  means that  $B$  has to have three arguments (i.e.  $B$  cannot occur alone). In the formulation of (\*) as above this is similar, and so O'Donnell's question can be answered positively.

Chapter IV, finally, is not related to Chapters II, III, but considers  $\lambda\beta\eta$ -calculus. Via a new concept of 'residual' for  $\beta\eta$ -reductions (for which the lemma of Parallel Moves holds, in contrast to the case of the ordinary residuals) we prove the Standardization and Normalization theorem for  $\lambda\beta\eta$ , thus solving some questions of Hindley. Here we profit from the concept of 'reduction diagram' and from our first proof of the Standardization Theorem for  $\lambda\beta$  in I.9. Also an extension of the result in I.12 about cofinal reductions is given.





## INTERDEPENDENCE OF THE SECTIONS

The interdependence of the sections is as suggested by the following tree.

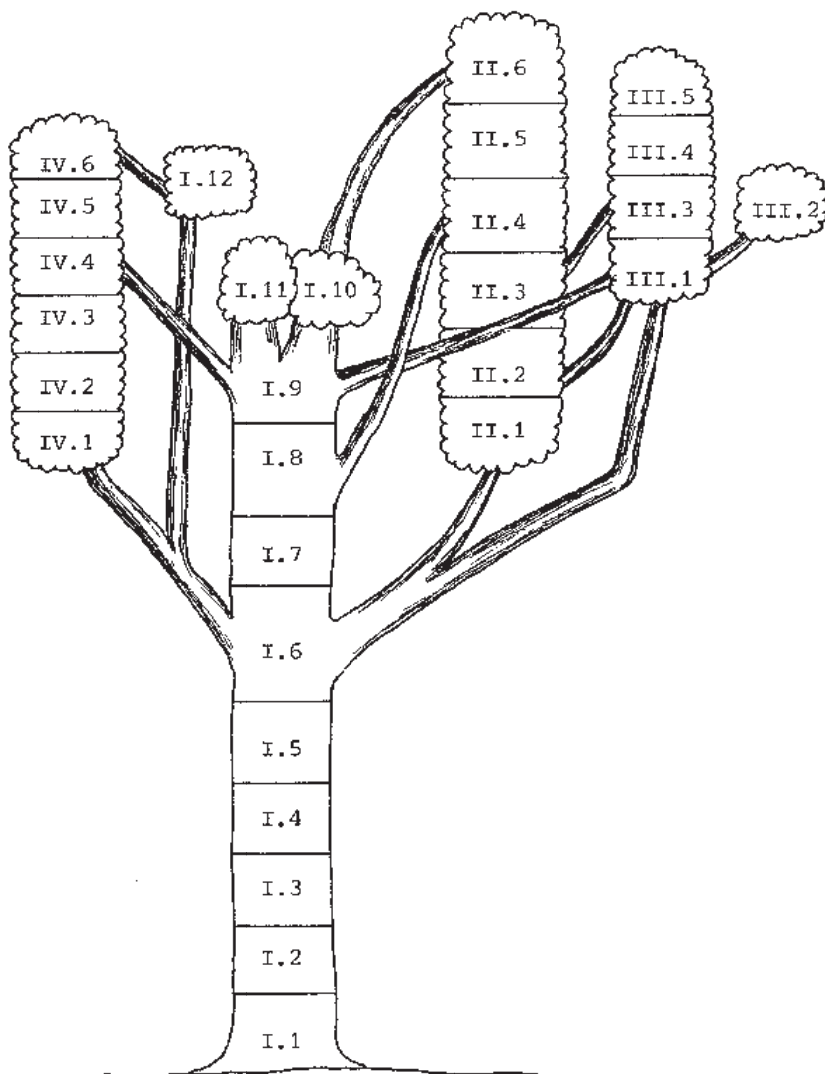



## CHAPTER I

 $\lambda$ B-CALCULUS AND DEFINABLE EXTENSIONS

## 1. LAMBDA TERMS

1.1. The *alphabet* of the  $\lambda$ -calculus consists of symbols  $v_i$ , for all  $i \in \mathbb{N}$ , brackets ( ) and  $\lambda$ . From this alphabet the set  $\text{Ter}(\lambda)$  of  $\lambda$ -terms is inductively defined as follows:

- (i)  $v_i \in \text{Ter}(\lambda)$  for all  $i \in \mathbb{N}$  (the variables)
- (ii)  $A, B \in \text{Ter}(\lambda) \Rightarrow (AB) \in \text{Ter}(\lambda)$  (application)
- (iii)  $A \in \text{Ter}(\lambda) \Rightarrow (\lambda v_i A) \in \text{Ter}(\lambda)$  for all  $i \in \mathbb{N}$ . ( $\lambda$ -abstraction)

If in (iii) the restriction is added: "if  $v_i$  occurs as a free variable in  $A$ " (see 1.3 below) we get the set  $\text{Ter}(\lambda I)$  of  $\lambda I$ -terms.

Sometimes we will consider  $\lambda$ -terms plus a set of *constants*  $C = \{\square, A, B, C, \dots\}$ . In that case we change  $\text{Ter}(\lambda)$  into  $\text{Ter}(\lambda C)$  in the above clauses and add

- (0)  $X \in \text{Ter}(\lambda C)$  for all  $X \in C$ .

1.2. Some *notational conventions* will be employed:

- (1) the outermost brackets of a term will be omitted;
- (2) we will use  $a, b, c, \dots, x, y, z$  as metavariables for  $v_0, v_1, \dots$ ;
- (3) instead of e.g.  $\lambda x(xx)$  we will also use the dot notation  $\lambda x.xx$ , and instead of  $\lambda xx$  or  $\lambda xy$  we write  $\lambda x.x$  resp.  $\lambda x.y$ ;
- (4) a number of brackets will be omitted under the convention of *association to the left*; that is if  $A_1, A_2, \dots, A_n \in \text{Ter}(\lambda)$  then  $A_1 A_2 \dots A_n$  abbreviates  $((\dots((A_1 A_2) A_3) A_4) \dots) A_n$ ;
- (5) for a multiple  $\lambda$ -abstraction  $\lambda x_1 (\lambda x_2 (\dots (\lambda x_n . A) \dots))$  we will write  $\lambda x_1 x_2 \dots x_n . A$ . (The  $x_i$  ( $i = 1, \dots, n$ ) will be in practice pairwise distinct, although e.g.  $\lambda xx.xx$  is a well-formed term. See 1.6.)

1.3. Let  $x$  be some variable and  $M \in \text{Ter}(\lambda)$ . Define  $\phi_x(M)$  by induction on the structure of  $M$  as follows:

- (i)  $\phi_x(x) = \underline{x}$  and  $\phi_x(y) = y$  for  $x \neq y$ .
- (ii)  $\phi_x(AB) = (\phi_x A)(\phi_x B)$
- (iii)  $\phi_x(\lambda x.A) = \lambda x.A$  and  $\phi_x(\lambda y.A) = \lambda y.\phi_x A$  for  $x \neq y$ .

EXAMPLE.  $\phi_x(\lambda y.xx((\lambda x.xx)(yx))) = \lambda y.\underline{xx}((\lambda x.xx)(\underline{yx}))$ . So  $\phi_x$  underlines some  $x$ 's in  $M$ ; namely the *free occurrences* of  $x$  in  $M$ . Let  $\Phi_x(M)$  be the set of those occurrences, and define the set of occurrences of free variables of  $M$ :

$$\text{FV}(M) = \bigcup_{x \in \text{VAR}} \Phi_x(M),$$

where VAR is the set of variables. An occurrence of  $x$  in  $M$  is called *bound* when it is  $\notin \text{FV}(M)$ .  $M$  is a *closed term* if  $\text{FV}(M) = \emptyset$ .

1.4. For every variable  $x$  and  $N \in \text{Ter}(\lambda)$  we have a *substitution operator*  $\sigma_x = [x := N]$ , a mapping from  $\text{Ter}(\lambda)$  to  $\text{Ter}(\lambda)$ , defined inductively as follows:

- (i)  $\sigma_x(x) = N$  and  $\sigma_x(y) = y$  for  $x \neq y$
- (ii)  $\sigma_x(AB) = (\sigma_x A)(\sigma_x B)$
- (iii)  $\sigma_x(\lambda x.A) = \lambda x.A$  and  $\sigma_x(\lambda y.A) = \lambda y.\sigma_x A$  for  $x \neq y$ .

So the mapping  $\sigma_x = [x := N]$  substitutes  $N$  for all the free occurrences of  $x$  in  $M$ , as is seen by looking at the parallel definition in 1.3.

Note that our substitution operator also yields 'dishonest' substitutions like

$$[x := yy](\lambda y.yx) = \lambda y.y(yy)$$

but that is intentional; see 1.5 below.

1.5. *Contexts.* Consider an extra constant  $\square$  and the set  $\text{Ter}(\lambda\{\square\})$  as defined in 1.1. The constant  $\square$  is intended to be a 'hole'; so a term  $\in \text{Ter}(\lambda\{\square\})$  is a  $\lambda$ -term containing some holes. We will only need  $\lambda$ -terms containing precisely one hole; they will be called *contexts*. We can also define them inductively as follows:

- (i)  $\square$  is a context (the trivial one)
- (ii) if  $A \in \text{Ter}(\lambda)$  and  $B$  is a context, then  $(AB)$  and  $(BA)$  are contexts
- (iii) if  $A$  is a context, then  $\lambda x.A$  is a context.

We use the notation  $\mathbb{C}[\ ]$  for a context. If  $M \in \text{Ter}(\lambda)$ , then  $\mathbb{C}[M] = [\square := M]$   $\mathbb{C}[\ ]$ , where it is obvious how to define  $[\square := M]$ . Here variables, free in  $M$ , may become bound in  $\mathbb{C}[M]$ .  $M$  is called a *subterm* of  $N \equiv \mathbb{C}[M]$ ; notation  $M \subseteq N$ . We will also write ' $s \in N$ ' for *symbols*  $s$  (i.e. variables or  $\lambda$  or brackets) occurring in  $N$ . Note that  $y \in \lambda x.y$  and  $y \subseteq \lambda x.y$ , but  $y \notin \lambda y.x$  and  $y \not\subseteq \lambda y.x$ .

1.6.  $\alpha$ -reduction. Expressions which result from each other by renaming bound variables should obviously be identified, for instance in calculus  $\int_0^1 x^2 dx = \int_0^1 y^3 dy$ , or in predicate logic  $\exists x.A(x) \equiv \exists y.A(y)$ . Therefore: let  $\lambda x.A \in \text{Ter}(\lambda)$  and  $y \notin \lambda x.A$ . Then we define  $\alpha$ -reduction  $\xrightarrow{\alpha}$  as follows:

$$\mathbb{C}[\lambda x.A] \xrightarrow{\alpha} \mathbb{C}[\lambda y.[x:=y]A] \text{ for every context } \mathbb{C}[\ ].$$

Let  $\equiv_{\alpha}$  denote the equivalence relation (' $\alpha$ -conversion') generated by  $\xrightarrow{\alpha}$ .

1.7. While  $\alpha$ -reduction is a mere technicality,  $\beta$ -reduction ( $\xrightarrow{\beta}$ ) which we are going to define now, is the basic concept of  $\lambda$ -calculus.

Terms of the form  $(\lambda x.A)B$  will be called  $\beta$ -redexes and in view of the intended interpretation of  $\lambda$ -terms we should like to replace such a  $\beta$ -redex by  $[x:=B]A$ . However, consider the following sequences of such reductions (i.e. replacements):

$$\begin{array}{c}
 (\lambda x.xx) (\lambda ab.ab) \\
 \downarrow \\
 (\lambda ab.ab) (\lambda ab.ab) \\
 \downarrow \\
 \lambda b. (\lambda ab.ab)b \equiv_{\alpha} \lambda b. (\lambda ac.ac)b \\
 \downarrow \quad \downarrow \\
 A \equiv \lambda b. (\lambda b.bb) \quad B \equiv \lambda b. (\lambda c.bc)
 \end{array}$$

Now, if our formalism used arrows, as in the example, to denote 'binding' of variables  $x$  by abstractors  $\lambda x$ , then the terms  $A, B$  (plus arrows) are syntactically equal and no harm is done in the step  $\xrightarrow{??}$ ; but it is implicit in the definition of 'free and bound' that a variable  $x$  is bound by the *nearest*  $\lambda x$ . Hence  $\lambda b. (\lambda b.bb)$  is to be interpreted as  $\lambda b. (\lambda b.bb)$  - and

so the step  $\xrightarrow{??}$  was erroneous.

This leads us to postulating a condition on  $\beta$ -redexes, for the moment only:

$(\lambda x.A)B$  is *unsafe* if some variable  $y (\neq x)$  is free in  $B$  and  $A$  has a sub-term  $\lambda y.C$  containing  $x$  as free variable.

Now we define *one-step  $\beta$ -reduction* by the clauses:

(i) if  $(\lambda x.A)B$  is a safe (i.e. not unsafe)  $\beta$ -redex and  $\mathbb{C}[\ ]$  a context, then

$$\mathbb{C}[(\lambda x.A)B] \xrightarrow{\beta} \mathbb{C}[x:=B]A$$

(ii) if  $M \equiv_{\alpha} M' \xrightarrow{\beta} N' \equiv_{\alpha} N$  for some  $M', N'$ , then  $M \xrightarrow{\beta} N$ .

There are several other ways to get around the  $\alpha$ -conversion problem; in BARENDREGT [71] an almost similar method is used; another way is to define  $[x:=N]$  such that  $\alpha$ -reduction is built in to prevent confusion of variables (but note that in  $[x:=N]$  we *intended* that variables could be 'captured!'); a third method is to work, in one way or another, with arrows like above (see also DE BRUIJN [72]).

Henceforth we will forget everything about  $\alpha$ -reduction. Instead of  $\equiv_{\alpha}$  we write just  $\equiv$  for *syntactical equality*.

Let  $R \equiv (\lambda x.A)B$  and  $R' \equiv [x:=B]A$ . Then the step  $\mathbb{C}[R] \xrightarrow{\beta} \mathbb{C}[R']$  is called a *contraction* of  $R$ , and  $R'$  is the *contractum equality*.

We will often omit the subscript  $\beta$  and write just  $M \rightarrow N$ . When we want to display the contracted redex  $R$  we will write  $M \xrightarrow{R} N$ .

The *transitive reflexive closure* of  $\rightarrow$  is denoted by  $\twoheadrightarrow$ . The equality (equivalence relation) generated by  $\rightarrow$  is called *convertibility* and written as  $\equiv_{\beta}$  or  $=$ .

Note that from the definition of  $\xrightarrow{\beta}$  it follows that for all terms  $A, B$ :

$$\begin{aligned} A \twoheadrightarrow B &\Rightarrow \mathbb{C}[A] \twoheadrightarrow \mathbb{C}[B] \\ A = B &\Rightarrow \mathbb{C}[A] = \mathbb{C}[B]. \end{aligned}$$

A *sequence of reduction steps* is mostly denoted by  $\mathcal{R}$  (plus subscripts etc.) e.g.

$$\mathcal{R} = M_0 \rightarrow M_1 \rightarrow \dots \rightarrow M_n.$$

Although it is a slight abuse of notation we sometimes write also

$$\mathcal{R} = M_0 \longrightarrow M_n.$$

1.7.1. REMARK. We will refer to the 'reduction system'  $\lambda\beta$ -calculus, consisting of the pair  $\langle \text{Ter}(\lambda), \xrightarrow{\beta} \rangle$ , also as  $\lambda$ -calculus or even  $\lambda$  without more. Likewise the reduction system  $\lambda I$ -calculus  $\langle \text{Ter}(\lambda I), \xrightarrow{\beta} \rangle$  will be referred to as  $\lambda I$ .

In section 5 we will consider 'abstract reduction systems'  $\langle A, \rightarrow \rangle$  where  $A$  is some set and  $\rightarrow$  a binary operation on  $A$ ; in Chapter II we introduce 'combinatory reduction systems', generalizing  $\lambda$ -calculus.

### 1.8. ADDITIONAL NOTATIONS

- (i) Instead of  $\lambda x_1 \dots x_n . A$  we use sometimes the vector notation  $\lambda \vec{x} . A$ ; likewise  $MN$  for  $MN_1 \dots N_n$ .
- (ii) In  $R \equiv (\lambda x . A)B$  we call  $\lambda x . A$  the *function part* of  $R$  and  $B$  the *argument* of  $R$ .
- (iii) *Simultaneous substitution.* Let  $\vec{x}$  be  $x_1, \dots, x_n$  and let no  $x_i$  be free in  $\vec{B} \equiv B_1, \dots, B_n$ . Then the result of the  $n$  reduction steps

$$(\lambda \vec{x} . A) \vec{B} \longrightarrow [x_n := B_n] \dots [x_1 := B_1] A \equiv C$$

can be seen as (and is in fact defined as) the *simultaneous substitution* of  $B_1, \dots, B_n$  for  $x_1, \dots, x_n$  in  $A$ . We will write

$$C \equiv [\vec{x} := \vec{B}]A \equiv [x_1, \dots, x_n := B_1, \dots, B_n]A.$$

Note the difference with the sequential substitution:

$$\lambda y_n . (--- (\lambda y_2 . (\lambda y_1 . A) B_1) B_2 ---) B_n \longrightarrow$$

$$[y_n := B_n] \dots [y_2 := B_2] [y_1 := B_1] A,$$

where  $y_{i+1}, \dots, y_n$  may be free in  $B_i$  ( $i = 1, \dots, n-1$ ).

- (iv) We often employ the usual convention of writing  $A(B_1, \dots, B_n)$  instead of  $[x_1, \dots, x_n := B_1, \dots, B_n]A$ , after a preceding declaration of the variables for which one has to substitute:



"Let  $A = A(x_1, \dots, x_n)$ ", or implicitly as in:

$$(\lambda xy. A(x, y))BC \longrightarrow A(B, C).$$

Note that such a declaration does not say anything about  $FV(A)$ , unless explicitly stated otherwise (as in 1.10).

## 1.9. NORMAL FORMS

1.9.1. DEFINITION. A  $\lambda$ -term  $M$  not containing redexes is called a *normal form*. (Or:  $M$  is in normal form.)

Notation:  $M \in NF$ .

Obviously, the goal of reducing a term is to reach a normal form, as a 'final answer' of the computation. However, not every term can be reduced to a normal form. The simplest example is the term  $\Omega \equiv \omega\omega$  where  $\omega \equiv \lambda x.xx$ ; then

$$\Omega \rightarrow \Omega \rightarrow \Omega \rightarrow \dots$$

and this is the only possible reduction. For other terms it depends on the chosen reduction whether or not the term 'normalizes'; e.g. abbreviating  $K \equiv \lambda xy.x$  and  $I \equiv \lambda x.x$  we have the infinite reduction

$$KI\Omega \rightarrow KI\Omega \rightarrow \dots$$

but also

$$KI\Omega \rightarrow I, \quad \text{a normal form.}$$

## 1.9.2. DEFINITION.

(i)  $M$  has a normal form  $\iff \exists N \in NF \ M \longrightarrow N$ .

Instead of 'M has a n.f.' we will also say:

$M$  is *weakly normalizing*. Notation:  $M \in WN$ .

(iii)  $M$  is *strongly normalizing*  $\iff$  every reduction of  $M$  must terminate eventually (in a normal form).

E.g.  $KI\Omega \in WN - SN$ .

Here the question arises whether a term can have two distinct normal forms. Fortunately this is not the case: if a term has a n.f., then that

nf. is unique, as we will prove later.

1.10. COMBINATORIAL COMPLETENESS. Let  $A(x_1, \dots, x_n) \in \text{Ter}(\lambda)$  be a term with free variables  $x_1, \dots, x_n$ . Then it is not hard to find an  $F \in \text{Ter}(\lambda)$  such that

$$F x_1 \dots x_n = A(x_1, \dots, x_n). \quad (I)$$

One simply takes  $F \equiv \lambda x_1 \dots x_n. A(x_1, \dots, x_n)$ ; then (I) holds (even with  $=$  replaced by  $\rightarrow$ ).

We say that  $\lambda$ -calculus satisfies the principle of '*combinatorial completeness*'. (In the system CL of the next section this principle is less trivial.)

1.11. FIXED POINTS. Surprisingly, every  $\lambda$ -term (when it is considered as a function  $\text{Ter}(\lambda)/\equiv \rightarrow \text{Ter}(\lambda)/\equiv$ ) has a *fixed point*:

$$\forall F \exists X \quad FX = X.$$

It is even possible to find such an  $X$  in a uniform way; that is, there is an  $Y \in \text{Ter}(\lambda)$  such that

$$\begin{aligned} \forall F \quad F(YF) &= YF, & \text{or equivalently,} \\ f(Yf) &= Yf & \text{for a variable } f. \end{aligned}$$

We will describe how to construct such an  $Y$ . Let us try to find a term  $\Omega_F$ , containing  $F$  as subterm, such that  $\Omega_F \rightarrow F\Omega_F$ . Suppose that  $\Omega_F \equiv \omega_F \omega_F$ , where the first  $\omega_F$  is meant to 'act' and the second  $\omega_F$  serves for the reconstruction of the original  $\omega_F$ . So  $\omega_F \omega_F \rightarrow F(\omega_F \omega_F)$ , which leads to requiring  $\omega_F x \rightarrow F(xx)$ .

Therefore, take:  $\omega_F \equiv \lambda x. F(xx)$ . Hence we can take

$$Y \equiv \lambda f. \omega_f \omega_f \equiv \lambda f. (\lambda x. f(xx)) (\lambda x. F(xx)).$$

The term  $Y$  is *Curry's fixed point combinator*. Using a slightly different construction we find *Turing's fixed point combinator*  $Y_T$  which has the technical advantage (not shared by  $Y$ ) that

$$\forall F \quad F(Y_T F) \leftarrow Y_T F$$

For, suppose as above  $Y_T \equiv \theta\theta$ . So  $\theta\theta F \longrightarrow F(\theta\theta F)$ ; hence we try to find  $\theta$  such that

$\theta xF \longrightarrow F(xxF)$ . Thus take  $\theta \equiv \lambda x f.f(xxF)$  and

$$Y_T \equiv (\lambda x f.f(xxF))(\lambda x f.f(xxF)).$$

In a similar way everybody can construct his own fixed point combinator  $\Gamma$ : by requiring  $\Gamma \equiv \gamma\gamma\dots\gamma$  ( $n \geq 2$  times) and proceeding as above, it is not hard to see that every choice

$$\gamma \equiv \lambda a_1 a_2 \dots a_{n-1} f.f(wf)$$

where  $w$  is an arbitrary word over the alphabet  $\{a_1, \dots, a_{n-1}\}$  of length  $n$ , yields a fixed point combinator  $\Gamma$ .

Sometimes it is convenient to have a *fixed point combinator with parameter(s)*  $\vec{P} \equiv P_1, \dots, P_m$ ; for example

$$Y_{\vec{P}} \equiv (\lambda x \vec{p} f.f(x\vec{p}f))(\lambda x \vec{p} f.f(x\vec{p}f)\vec{P}).$$

An amusing way of deriving new f.p. combinators from old ones is mentioned in BÖHM [66] (or see CURRY-HINDLEY-SELDIN [72], p.156): to find a solution  $Y$  for  $Yf = f(Yf)$ , or equivalently for  $Y = [\lambda y f.f(yf)]Y$ , amounts to the same thing as finding a fixed point of  $\lambda y f.f(yf)$ .

Hence: if  $Y'$  is a f.p. combinator, then  $Y'' \equiv Y'\lambda y f.f(yf)$  is a f.p. combinator. In this way one gets starting with (say) Curry's  $Y$ , an infinite sequence of f.p. combinators. Notice that  $Y_T$  is the second one in the sequence. (One can prove that they are pairwise invertible.)

The main application of fixed point combinators is that we can "define" a term  $X$  in an impredicative way, i.e. in terms of  $X$  itself; that is, every equation in  $X$  of the form  $X = A(X)$ , has a solution, namely  $X \equiv Y\lambda x.A(x)$ .

And if  $Y_T$  is used one has even:  $X \longrightarrow A(X)$ .

An example of a simple application: let  $P$  and  $H$  be such that  $P \longrightarrow \lambda x.P(xF)$  and  $H \longrightarrow \lambda y.H$ . Then  $PH \longrightarrow P(HF) \longrightarrow PH \longrightarrow \dots$  ( $P$  produces food  $F$  for the hungry  $H$ .)

Finally, let us mention that it is straightforward to generalize this to the case of  $n$  'equations' in  $X_1, \dots, X_n$  as follows:

$$\begin{cases} X_1 \longrightarrow A_1(X_1, \dots, X_n) \\ X_n \longrightarrow A_n(X_1, \dots, X_n). \end{cases}$$

(Multiple fixed point theorem)

PROOF. For  $n = 2$ : define  $\langle M \rangle := \lambda z.zM$  and the pairing  $\langle M, N \rangle := \lambda z.zMN$ , where  $z$  is not free in  $M, N$ . Then  $\langle K \rangle$  and  $\langle KI \rangle$ , where  $K \equiv \lambda xy.y$  and  $I \equiv \lambda x.x$ , are the corresponding unpairing operators (write  $\langle K \rangle A =: A_0$  and  $\langle KI \rangle A =: A_1$ ):

$$\langle M, N \rangle_0 \longrightarrow \langle M, N \rangle K \longrightarrow KMN \longrightarrow M$$

$$\langle M, N \rangle_1 \longrightarrow \langle M, N \rangle (KI) \longrightarrow KIMN \longrightarrow N.$$

Now to solve

$$\begin{cases} X \longrightarrow A(X, Y) \\ Y \longrightarrow B(X, Y) \end{cases}$$

it suffices to find a  $Z$  such that  $Z \longrightarrow \langle A(Z_0, Z_1), B(Z_0, Z_1) \rangle$ , which can easily be done: take  $Z \equiv Y_T \lambda z. \langle A(z_0, z_1), B(z_0, z_1) \rangle$ . Finally, take  $X \equiv Z_0$  and  $Y \equiv Z_1$ .  $\square$

REMARK. For another proof, working also for  $\lambda I$ -calculus (in contrast to this proof), see BARENDREGT [76].

REMARK. The multiple fixed point theorem also holds for an *infinite* system  $\Sigma$  of reduction 'equations' if  $\Sigma$  is recursively given. This requires the deeper result of the *representability of recursive functions* in the  $\lambda$ -calculus. See BARENDREGT [71].

## 1.12. DEFINABLE EXTENSIONS

1.12.1. DEFINITION. (i) Let the alphabet of  $\lambda$ -calculus be extended by a set  $P = \{P_i \mid i \in I\}$  of new constants and let  $\text{Ter}(\lambda P)$  be the set of ' $\lambda P$ -terms' as defined in Definition 1.1.

Furthermore, let  $J \subseteq I$  and let for all  $i \in J$  a reduction rule be given of the following form:

$$P_i X_1 \dots X_{n_i} \longrightarrow Q_i (X_1, \dots, X_{n_i}, P_{j_1}, \dots, P_{j_{m_i}})$$

for all  $X_1, \dots, X_{n_i} \in \text{Ter}(\lambda P)$ . Here  $n_i \geq 0$ , and the  $Q_i$  are  $\lambda P$ -terms containing some of the meta-variables  $X_1, \dots, X_{n_i}$  (possibly none), but no other meta-variables. The  $X_1, \dots, X_{n_i}$  must be pairwise distinct.

Then the reduction system consisting of  $\text{Ter}(\lambda P)$  and as reduction rules:  $\beta$ -reduction and the  $P_i$ -rules ( $i \in J$ ), is called a *definable extension* of  $\lambda$ -calculus. We will refer to it as ' $\lambda P$ -calculus'.

(ii) Terms of the form  $P_i X_1 \dots X_{n_i}$  ( $i \in J$ ) are called  $P_i$ -redexes;  $n_i$  is the arity of the  $P_i$ -redex. Constants  $P_i$  where  $i \notin J$  are called *inert constants* (they do not exhibit any activity since there is no reduction rule for them).

1.12.2. REMARK. (i) In Chapter III we will consider reduction rules without the restriction that the meta-variables  $X_1, \dots, X_{n_i}$  be pairwise distinct.

(ii) The reason for this terminology is that (if  $I$  is finite) by virtue of the combinatorial completeness and the (multiple) fixed point theorem, we can "solve" the set of "reduction-equations with unknowns  $P_i$ "; that is we can find  $\lambda$ -terms  $P_i$  and  $\beta$ -reductions

$$\mathcal{R}_i = P_i X_1 \dots X_{n_i} \xrightarrow{\beta} Q_i (X_1, \dots, X_{n_i}, P_{j_1}, \dots, P_{j_{m_i}}).$$

If  $I$  is infinite, we will in general not be able to find defining reductions  $\mathcal{R}_i$ , but by a slight abuse of terminology we will also call such extensions definable (anyway, each finite part is definable).

EXAMPLES. 1.  $\lambda$ -calculus +  $\{D, E\}$  and  $EM \longrightarrow DMM$  for all  $M \in \text{Ter}(\lambda\{D, E\})$ .  $D$  is an inert constant.

2.  $\lambda$ -calculus +  $\{P\}$  and  $PABC \rightarrow P(AC)B$  for all  $A, B, C$ .  $P$  can be defined by e.g.  $P \equiv Y_T \lambda pabc.p(ac)b$ .

These two examples will play a role in the sequel.

3. An arbitrarily chosen example:  $\lambda$ -calculus +  $\{P, Q, R\}$  and the rules

$$\begin{aligned} PABC &\rightarrow AP(ACQ) \\ QA &\rightarrow \lambda x.xAPR \\ RABCD &\rightarrow AC(P\lambda x.xQ)AR \end{aligned}$$

1.13. REMARK. The definable extensions of  $\lambda$ -calculus are closely related to *Recursive Program Schemes* (RPS); see LÉVY-BERRY [79], MANNA [74]. In the theory of RPS's we have disjoint sets  $F = \{f_1, \dots, f_m\}$ , the *basic function symbols*, standing for 'known' functions, and  $\Phi = \{\phi_1, \dots, \phi_N\}$ , the *unknown function symbols*. Each  $f_i$  and  $\phi_i$  has an *arity*  $\rho(f_i)$ , resp.  $\rho(\phi_i) \geq 0$ .

Now a recursive program scheme  $\Sigma$  is a system of equations

$$\phi_i(x_1, \dots, x_{\rho(\phi_i)}) = \tau_i \quad (i = 1, \dots, N),$$

where the  $\tau_i$  are *terms* built up in the usual way from symbols in  $F$ ,  $\Phi$  and variables  $x_1, \dots, x_{\rho(\phi_i)}$ .

EXAMPLE.

$$\Sigma \equiv \begin{cases} \phi_1(x) = f_1(x, \phi_1(x), \phi_2(x, y)) \\ \phi_2(x, y) = f_2(\phi_2(x, x), \phi_1(f_3)). \end{cases}$$

The connection with definable extensions  $\lambda P$  of  $\lambda$ -calculus is evident. (Replace in  $\Sigma$  '=' by ' $\rightarrow$ '.) The basic function symbols  $f_i$  are what we called in 1.11 'inert' constants  $P_i$ , the unknown function symbols are the remaining  $P_j$  in  $P$ . The definable extensions are slightly more general, syntactically speaking, than the RPS's since in  $\lambda P$  also  $\lambda$ -terms occur and since in an RPS an  $n$ -ary symbol  $\phi$  has to have  $n$  arguments:  $\phi(t_1, \dots, t_n)$ , whereas in  $\lambda P$  for an  $n$ -ary  $P$  also  $PM_1, PM_1M_2, \dots$  are well-formed terms (see the examples above).

1.14. REMARK. Since almost everything in this Chapter will prove to hold for definable extensions, it will hold also for RPS's (anyway in this simple version, where the only operation is substitution of unknown function symbols). Almost all of these results for RPS's were obtained already in LÉVY-BERRY [79]; but in the sequel one finds some alternative proofs for some of these facts (FD, standardization).

## 2. COMBINATORS

2.1. We will now introduce a system called *Combinatory Logic*, or CL, which is closely related to  $\lambda$ -calculus. The main difference is that CL is *variable free*. The CL-terms or *combinators* are built up from the alphabet

$\{(\cdot), I, K, S\}$  as follows:

- (i)  $I, K, S \in \text{Ter}(\text{CL})$
- (ii)  $A, B \in \text{Ter}(\text{CL}) \Rightarrow (AB) \in \text{Ter}(\text{CL})$ .

Just as before we will admit *meta-variables*  $A, B, C, \dots$ , ranging over CL-terms, in a meta-CL-term. Again, we use the convention of association to the left.

2.2. *Reduction* in CL is generated by the rules

- (i)  $IA \rightarrow A$
- (ii)  $KAB \rightarrow A$
- (iii)  $SABC \rightarrow AC(BC)$

for all CL-terms  $A, B, C$ . Here 'generated' means:

$$A \rightarrow B \Rightarrow \mathcal{C}[A] \rightarrow \mathcal{C}[B]$$

for every context  $\mathcal{C}[\ ]$ . Contexts  $\mathcal{C}[\ ]$  are defined as in  $\lambda$ -calculus, see section 1; and the same for  $\equiv, \rightarrow, \rightarrow^*, =$ .

Terms of the form  $IA, KAB, SABC$  are called (*I*-, *K*-, *S*-) *redexes*. Again a term is a normal form (nf) iff it contains no redexes and has a nf if it reduces to one.

2.3. REMARK. One may also take  $S, K$  alone as basic combinators for CL, since  $I$  can then be defined:  $I \equiv SKK$ . For, then  $IA \equiv SKKA \rightarrow KA(KA) \rightarrow A$ . For several other bases for CL, see CURRY, FEYS [58].

2.4. REMARK. Call a combinator 'flat' if it has no visible brackets (under the usual convention). E.g.  $SISSII$ .

One can prove that all flat combinators built up from  $S$  and  $K$ , have a normal form (moreover they are strongly normalizing). If the combinator  $I$  is included as well, this does not hold:

$$\begin{aligned} SISSII &\rightarrow \\ IS(SS)SII &\rightarrow \\ S(SS)SII &\rightarrow \\ SSI(SI)I &\rightarrow \\ S(SI)(I(SI))I &\rightarrow \\ S(SI)(SI)I &\rightarrow \end{aligned}$$

$$\begin{array}{l} \curvearrowright SII(SII) \longrightarrow \\ I(SII)(I(SII)) \longrightarrow \\ \curvearrowleft SII(I(SII)) \end{array}$$

2.5. INTERMEZZO. The connection between reduction in  $\lambda$ -calculus and CL.

This subsection, in which some terminology from the sequel is used, is only needed in Chapter III.

Usually one includes variables in the term-formation of CL-terms. This may seem a bit odd after claiming that CL is the variable free version of  $\lambda$ -calculus. The reason however is that the variables are needed to demonstrate the connection between  $\lambda$ -calculus and CL, namely to define abstraction  $[x]$  as an analogon of  $\lambda x$ .

We will give a slightly different treatment, in order to show how far the correspondence between reduction in CL and reduction in  $\lambda$ -calculus reaches.

2.5.1. DEFINITION.  $\lambda\beta + CL$  is the definable extension of  $\lambda$ -calculus obtained by adding  $S, K, I$  plus their reduction rules (as above). By  $\xrightarrow{CL}$  we denote the contraction of an  $S$ -,  $K$ -,  $I$ -redex. Moreover we add a reduction rule, called 'translation', written  $\xrightarrow{\tau}$ , defined by:

- (i)  $\lambda x.x \xrightarrow{\tau} I$
- (ii)  $\lambda x.A \xrightarrow{\tau} KA$  if  $x \notin FV(A)$
- (iii)  $\lambda x.AB \xrightarrow{\tau} S(\lambda x.A)(\lambda x.B)$  if the previous rules are not applicable.

EXAMPLE.  $(\lambda x.xx)(\lambda x.xx) \xrightarrow{\tau} S(\lambda x.x)(\lambda x.x)(\lambda x.xx) \xrightarrow{\tau} \xrightarrow{\tau} SII(\lambda x.xx) \xrightarrow{\tau} SII(SII)$ .

It is routine to prove that  $\xrightarrow{\tau}$  is strongly normalizing and has the Church-Rosser property. Hence every term  $M$  in  $\lambda\beta + CL$  has a unique  $\tau$ -normal form, called  $\tau(M)$ .

A more economic variant of  $\tau$ , called  $\tau'$ , is obtained by changing  $\tau$  into  $\tau'$  above and inserting between (ii) and (iii) the rule

- (ii)'  $\lambda x.Ax \xrightarrow{\tau'} A$  if  $x \notin FV(A)$ .

A comparison:  $\tau'(\lambda xyz.xz(yz)) \equiv S$  while  $\tau(\lambda xyz.xz(yz)) \equiv S(S(KS)(S(KK)(S(KS)(S(S(KS)(S(KK)I))(KI)))))(S(S(KS)(S(KK)I))(KI))$ .



Unfortunately it is *not* so that  $M \xrightarrow[\beta]{\rightsquigarrow} N \Rightarrow \tau(M) \xrightarrow[\text{CL}]{\rightsquigarrow} \tau(N)$ .

EXAMPLE.

$$\begin{array}{ccc} M \equiv \lambda x. (\lambda y. y) (xx) & \xrightarrow[\tau]{\rightsquigarrow} & S(KI) (SII) \equiv \tau(M) \\ \downarrow & & \\ N \equiv \lambda x. xx & \xrightarrow[\tau]{\rightsquigarrow} & SII \equiv \tau(N). \end{array}$$

The problem is that the reductions  $\xrightarrow[\tau(iii)]{\rightsquigarrow}$  and  $\xrightarrow[\beta]{\rightsquigarrow}$  or  $\xrightarrow[\text{CL}]{\rightsquigarrow}$  'interfere' (are ambiguous) in the sense of Chapter II; for consider

$$\begin{array}{ccc} \lambda x. (\lambda y. A(y)) B & \xrightarrow[\tau]{\rightsquigarrow} & S(\lambda xy. A(y)) (\lambda x. B) \\ \downarrow \beta & & \downarrow \\ \lambda x. A(B) & \text{-----} & ? \end{array}$$

Another source of trouble is demonstrated in the following example:

$$\begin{array}{ccc} \lambda x. \mathcal{C}[KAB(x)] D & \xrightarrow[\tau]{\rightsquigarrow} & S(\lambda x. \mathcal{C}[KAB(x)]) (\lambda x. D) \\ \downarrow \text{CL} & & \downarrow \text{CL} \\ \lambda x. \mathcal{C}[A] D & \xrightarrow[\tau]{\rightsquigarrow} & S(\lambda x. \mathcal{C}[A]) (\lambda x. D) \\ & & \downarrow \tau \\ & & S(K\mathcal{C}[A]) (KD) \\ \lambda x. \mathcal{C}[A] D & \xrightarrow[\tau]{\rightsquigarrow} & K(\mathcal{C}[A] D) \text{-----} ? \end{array}$$

where the context  $\mathcal{C}[\ ]$  and the terms  $A, B, D$  are arbitrary but such that  $x$  occurs only free in  $B$ .

Let us remove the cause of this trouble by defining:

- (i) a ( $\beta$ - or  $\text{CL}$ -)redex  $R$  occurring in  $M \in \lambda\beta + \text{CL}$  is *safe* iff  $R$  does not occur inside a subterm  $\lambda x. A$  of  $M$ .
- (ii) A ( $\beta$ - or  $\text{CL}$ -)reduction in  $\lambda\beta + \text{CL}$  is *safe* iff only safe redexes are contracted in it.

Now we can state the following fact:

**2.5.2. PROPOSITION.** Let  $A, B, C \in \lambda\beta + \text{CL}$  be such that  $A \xrightarrow[\beta, \text{CL}]{\text{safe}} C$  and  $A \xrightarrow[\tau]{\rightsquigarrow} B$ . Then there is a  $D$  such that  $B \xrightarrow[\beta, \text{CL}]{\text{safe}} D$  and  $C \xrightarrow[\tau]{\rightsquigarrow} D$ . Likewise for  $\tau'$ .

In a diagram:

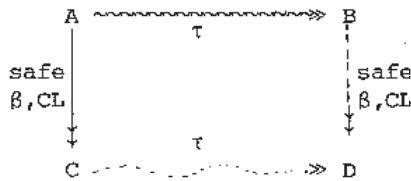

where the dashed or dotted arrows have the usual existential meaning.

PROOF. It is sufficient to prove the proposition for the case that  $A \xrightarrow{\tau} B$  is in fact one step. Since the proof is tedious but routine, we will sketch it only.

In case the step  $A \xrightarrow{\tau} B$  is by clause (i), (ii) (or (ii)' for  $\tau'$ ) of the definition of  $\tau(\tau')$ , (1) follows easily since then (say for clause (i)):

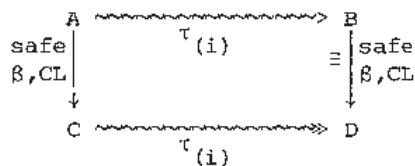

and now (1) is a direct consequence of the fact that the right side of this "elementary diagram" does not split into more steps.

In case  $A \xrightarrow{\tau} B$  is by clause (iii), we claim:  $\forall ABCD$

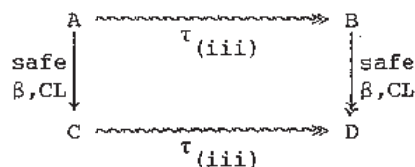

from which (1) also follows.

If  $A \rightarrow C$  is a CL-step, the claim is easy to prove.

If  $A \rightarrow C$  is a  $\beta$ -step, say that  $R$  is the contracted redex. Underline the head- $\lambda$  of  $R$  with  $-$ , and underline the head- $\lambda$ 's of the " $\tau_{(iii)}$ -redexes"  $\lambda x.FG$  with  $\sim$ .

Case (a). The symbols  $-$  and  $\sim$  are disjoint. No problem.

Case (b). Else, perform in the reduction  $A \xrightarrow{\tau} B$  first the  $\tau_{(iii)}$ -contraction of the  $\lambda x.FG \tau_{(iii)}$ -redex.

Then we have the following situation:

$$\begin{array}{ccccc}
A \equiv \lambda x. (FG)H & \xrightarrow{\tau(iii)} & S(\lambda x.F)(\lambda x.G)H & \xrightarrow{\tau(iii)} & B \\
\downarrow \beta, \text{safe} & & \downarrow \text{CL, safe} & & \downarrow \text{CL, safe} \\
& & B' \equiv \lambda x.FH((\lambda x.G)H) & \xrightarrow{\tau(iii)} & B'' \\
& & \downarrow \beta & & \downarrow \beta, \text{safe} \\
& & \downarrow \beta & & \downarrow \\
C \equiv F(H)(G(H)) & \equiv & F(H)(G(H)) & \xrightarrow{\tau(iii)} & D
\end{array}$$

The completion of the diagram as shown, gives no problems, since the two new  $\beta$ -steps are in the easy case (a) w.r.t. the  $\xrightarrow{\tau(iii)}$ -reduction from  $B'$  to  $B''$ .

The safety condition is easily checked.  $\square$

An example of safe reduction is *head-reduction*, i.e. the redex to be contracted occurs at the head of the term. (*Leftmost* reduction, i.e. contracting the redex whose head-symbol is leftmost of all the redexes, is not always safe however.) So e.g. the reduction  $Y_T M \xrightarrow{\beta} M(Y_T M)$  'translates well', since it is a head-reduction, into  $\tau'(Y_T M) \xrightarrow{\text{CL}} \tau'(M(Y_T M))$ . Here  $\tau'(Y_T) \equiv [S(K(SI))(SII)][S(K(SI))(SII)]$ .

From the previous proposition we conclude at once the

### 2.5.3. THEOREM (Combinatory completeness of CL).

Given a 'meta-CL-term'  $M(A_1, \dots, A_n)$  in which meta-variables  $A_1, \dots, A_n$  occur, one can find a CL-term  $N$  such that

$$NA_1 \dots A_n \xrightarrow{\text{CL}} M(A_1, \dots, A_n).$$

PROOF. Let  $N' \in \lambda\beta + \text{CL}$  be  $\lambda x_1 \dots x_n. M(x_1, \dots, x_n)$ . Then obviously  $N'A_1 \dots A_n \xrightarrow{\beta} M(A_1, \dots, A_n)$  by a head-reduction for all  $A_1, \dots, A_n \in \text{CL}$ .

Hence by the proposition (since head-reduction is safe):

$$\tau(N'A_1 \dots A_n) \xrightarrow{\text{CL}} \tau(M(A_1, \dots, A_n)) \equiv M(A_1, \dots, A_n).$$

The last identity is due to the fact that  $M$  is a (meta) CL-term, so (containing no  $\lambda$ 's) a  $\tau$ -normal form.

Now take  $N \equiv \tau N'$ , then  $\tau(N'A_1 \dots A_n) \equiv NA_1 \dots A_n$  and the result follows.  $\square$

2.5.4. REMARK. (i) In the other direction, the translation is easy: let for a CL-term  $M$ ,  $M_\lambda$  be the result of replacing  $I$  by  $\lambda x.x$ ,  $K$  by  $\lambda xy.x$  and  $S$  by  $\lambda xyz.xz(yz)$ . Then obviously

$$M \xrightarrow{\text{CL}} M' \Rightarrow M_\lambda \xrightarrow{\beta} M'_\lambda .$$

(ii) If  $M$  is a CL-term having a normal form, or even in nf, it does not follow that the  $\lambda$ -term  $M_\lambda$  has a nf too.

Counterexample:  $M \equiv S(K\omega)(K\omega)$  where  $\omega \equiv SII$ .

This is not due to the erasing nature of  $K$ ; in the non-erasing variant  $CL_I$  of CL (which is to CL what  $\lambda I$ -calculus is to  $\lambda$ -calculus) based on the primitive combinators  $\{I, S, B, C\}$  where  $BXYZ \rightarrow X(YZ)$  and  $CXYZ \rightarrow XZY$ , one has similar counterexamples, e.g.  $B(CI\omega)(C\omega)$  and  $S(CI(CI\omega))(C\omega)$ .

One gets a better correspondence between  $\lambda$ -calculus and CL by considering convertibility '=' instead of reduction and by adding extensionality (' $\eta$ -reduction'). Further, a still better correspondence is obtained by defining the so called 'strong reduction' in CL. See CURRY-FEYS [58], CURRY, HINDLEY, SELDIN [72], HINDLEY, LERCHER, SELDIN [72], STENLUND [72] and BARENDREGT [80].

### 3. LABELS AND DESCENDANTS

#### 3.0. INTRODUCTION

There is a clear intuition of symbols being *moved* (multiplied, erased) during a reduction; so we can trace them. This gives rise to the concept of '*descendants*' which we introduce by means of a  $\lambda$ -calculus in which symbols can be marked (by some color, say) in order to be able to keep track of them. This is done in 3.1 - 3.3, and for definable extensions  $\lambda P$  in 3.4. Then we introduce '*underlining*' in 3.5. Up to there, the markers (or labels) *do not affect the admissible reductions* since they are merely a book-keeping device.

This is different however in the remainder of this section: there the labels *do* affect the allowed reductions. In 3.6 we introduce '*developments*', in 3.7 the  $\lambda^{\text{HW}}$ -calculus of Hyland and Wadsworth, in 3.9 the  $\lambda^{\text{L}}$ -calculus of Lévy. At the end of this section all these systems with some of their relations are brought together in a figure.

3.1. DEFINITION. Let  $M \in \text{Ter}(\lambda)$  and let  $\dot{A}$  be some set of symbols, called *labels* or *indexes*. Then  $\text{Ter}(\lambda_{\dot{A}})$  is defined inductively as follows:

- (i)  $x^a \in \text{Ter}(\lambda_{\dot{A}})$  for all variables  $x$  and all  $a \in \dot{A}$
- (ii)  $A, B \in \text{Ter}(\lambda_{\dot{A}}) \Rightarrow (AB)^a \in \lambda_{\dot{A}}$  for all  $a \in \dot{A}$
- (iii)  $A \in \text{Ter}(\lambda_{\dot{A}}) \Rightarrow (\lambda x.A)^a \in \text{Ter}(\lambda_{\dot{A}})$  for all  $x$  and all  $a \in \dot{A}$ .

A term  $A \in \text{Ter}(\lambda_{\dot{A}})$  will sometimes be written as  $M^I$  where  $M$  is the  $\lambda$ -term obtained from  $A$  by erasing the labels and  $I: \text{Sub}(M) \rightarrow \dot{A}$  is the indexing map (or *labeling*) corresponding to  $A$ . Here  $\text{Sub}(M)$  is the set of occurrences of subterms of  $M$ .

EXAMPLE (in case  $\dot{A} = \mathbb{N}$ ):

$$M^I \equiv ([\lambda x. (x^7 x^8)^{20} (y^1 z^0)^2]^{37})^I.$$

Instead of looking at  $M^I$  as a  $\lambda$ -term whose *subterms* are labeled, one can also consider  $I$  as an indexing of the *symbols* of  $M$ :

$$M^I \equiv ([\lambda x \ (x \ x) \ ] \ (y \ z) \ ) \\ 37 \ 4 \ 4 \ 20 \ 7 \ 8 \ 20 \ 4 \ 2 \ 1 \ 0 \ 237$$

such that matching brackets get the same label and an abstractor  $\lambda x$  gets the same label as the 'corresponding' brackets. The (psychological) advantage is that  $\text{Sub}(M)$  is partially ordered (by  $\subseteq$ ) while  $\text{Symb}(M)$ , the set of symbol-occurrences, is linearly ordered.

If  $\dot{A} = \mathbb{N}$ , we can identify 'label 0' with 'no label'; thus we obtain also *partial* indexings.

Sometimes we will write the  $\dot{A}$ -labels as superscripts, sometimes as subscripts.

3.2. LABELED  $\beta$ -REDUCTION. Our first use of labels will be: *tracing subterms* (or symbols) during a reduction. Consider the  $\beta$ -redex  $M^I$  above which served as example, and view the labels as if they were firmly attached to the symbols. (So we can conveniently visualize the labels as *colors*.) Then it is almost obvious what the labeled contractum of  $M^I$  should be:

$$( \ (y \ z) \ (y \ z) \ ) \\ 20 \ 2 \ 1 \ 0 \ 2 \ 2 \ 1 \ 0 \ 2 \ 20$$

The 'almost' is because it requires a moment of thought to see that the outermost brackets must have label 20 and not 37 or 4.

It is now obvious how to define *labeled*  $\beta$ -reduction, notation  $\xrightarrow{\beta_A}$  :

$$((\lambda x.A)^a B)^b \longrightarrow [x:=B]A$$

for all  $\text{Ter}(\lambda_A)$ -terms  $A, B$ . Here substitution  $\sigma = [x:=B]$  is defined by

$$\sigma(x^a) = B, \quad \sigma(y^a) = y^a \quad \text{for } y \neq x$$

$$\sigma(AB)^a = ((\sigma A)(\sigma B))^a$$

$$\sigma(\lambda x.A)^a = (\lambda x.\sigma A)^a.$$

This 'reduction system', consisting of the set of terms  $\text{Ter}(\lambda_A)$  and reduction rule  $\beta_A$ , will be called  $\lambda_A$ -calculus.

3.3. DESCENDANTS. Consider  $M \in \lambda$  and a  $\beta$ -reduction step  $\mathcal{R} = M \xrightarrow{R} N$ . Let  $I: \text{Sub}(M) \longrightarrow A$  be a labeling of  $M$ . Then, obviously,  $\mathcal{R}$  and  $I$  determine in a unique way the  $\beta_A$ -reduction step  $\mathcal{R}^* = M \xrightarrow{I} N^J$  for some labeling  $J$  of  $N$  (simply by contracting the 'same' redex  $R$ , but now also taking care of the labels).

Now let  $I$  be an *initial* labeling, that is: labels of distinct subterm occurrences are distinct. (So let  $A$  be infinite.) Define for all symbol occurrences  $s, t \in M$  and for all subterm occurrences  $S, T \subseteq M$  the following relation:

$$s \dashrightarrow t \quad \text{iff} \quad J(s) = J(t)$$

$$S \dashrightarrow T \quad \text{iff} \quad J(S) = J(T).$$

In case  $\mathcal{R}$  consists of several steps,  $\mathcal{R} = M \twoheadrightarrow N$ , we write  $s \dashrightarrow t$  resp.  $S \dashrightarrow T$ . We say that  $s$  *descends* to  $t$ , or that  $t$  is a *descendant* of  $s$ , or that  $s$  is an *ancestor* of  $t$ ; likewise for  $S$  and  $T$ .

### 3.3.1. REMARKS.

- (i) Let  $M \xrightarrow{R} N$ . Then the redex  $R \equiv (\lambda x.A)B$  has no descendants in  $N$ . The same holds for  $(\lambda x.A)$  and the  $x$ 's free in  $A$ .
- (ii) Descendants of a redex are often called *residuals*. Note that residuals are again redexes.

- (iii) Notice that if  $M \rightarrow N$  ( $M, N \in \lambda$ ) and  $A \subseteq M$ , then the descendants  $T_i \subseteq N$  of  $A$  are mutually disjoint. However in the case of a many step reduction  $M \twoheadrightarrow N$  this need not be the case: see Remark 4.4.2 below.
- (iv) Note also that if  $\mathcal{R} = M \rightarrow \dots \rightarrow M'$  and  $s' \in M'$  (resp.  $S' \subseteq M'$ ) then  $s'$  (resp.  $S'$ ) has a *unique ancestor*  $s \in M$  (resp.  $S \subseteq M$ ), which will in general depend on the actual reduction  $\mathcal{R}$  from  $M$  to  $M'$ .

### 3.4. DESCENDANTS FOR CL AND DEFINABLE EXTENSIONS $\lambda P$

Let  $\lambda P$  be a definable extension of  $\lambda$ . Again we will derive the concept of descendants for  $\lambda P$  from a labeled version  $(\lambda P)_A$ . The definition of  $(\lambda P)_A$ -terms is obtained from Def. 3.1 by adding to (i):  $P^a$  is a  $(\lambda P)_A$ -term for all  $P \in P$ ,  $a \in A$ .

Now to each  $P$ -rule of  $\lambda P$ ,

$$P A_1 \dots A_n \longrightarrow Q(A_1, \dots, A_n)$$

there correspond in  $(\lambda P)_A$  the rules

$$(\dots ((P^{a_0}_{A_1})^{a_1}_{A_2})^{a_2} \dots A_n)^{a_n} \longrightarrow Q(A_1, \dots, A_n)$$

for all  $a_0, \dots, a_n \in A$ . Note that in the RHS of those labeled  $P$ -rules no  $A$ -labels occur (i.e. only the zero label  $\emptyset$  which is not written); except of course the labels which occur in the  $(\lambda P)_A$ -terms substituted for the meta-variables  $A_1, \dots, A_n$ .

EXAMPLE. If  $PABC \longrightarrow B(PAAC)$  is a rule in  $\lambda P$ , then for all  $a, b, c, d \in A$  the rules  $((P^d_A)^a_B)^c_C \longrightarrow B(PAAC)$  are in  $(\lambda P)_A$ .

3.4.1. DESCENDANTS. Extend Def. 3.3 (of descendants) to definable extensions  $\lambda P$ , using the above definition of  $(\lambda P)_A$ .

3.4.2. REMARK. From this extended definition we have at once the following facts:

- (i) Like  $\beta$ -redexes, also  $P$ -redexes leave no residuals after their contraction.
- (ii) In contrast with  $\beta$ -reduction, when  $P$ -reductions are present *not every* subterm  $N' \subseteq M'$  in a reduction step  $M \twoheadrightarrow M'$  has an ancestor  $N \subseteq M$ .

E.g. in  $Pabc \rightarrow b(Paac)$  where  $a, b, c$  are variables all the subterms  $P, Pa, Paa, Paac, b(Paac)$  of  $b(Paac)$  have no ancestors in  $Pabc$ . But if  $N'$  has an ancestor, it is unique.

A motivation for this definition of descendants will follow now; first we need a definition.

### 3.4.3. DEFINITION.

- (i) Let  $PA_1 \dots A_n \rightarrow Q(A_1, \dots, A_n)$  be a rule in  $\lambda P$ . This  $P$ -rule is called *proper* if  $P$  "acts effectively" on all the  $A_1, \dots, A_n$ ; i.e. for no  $Q'(A_1, \dots, A_{n-1})$  (not containing the metavariable  $A_n$ ) we have  $Q \equiv Q'A_n$ .  
E.g.  $PABC \rightarrow B(PAA)C$  is not a proper rule, but

$$\begin{aligned} PABC &\rightarrow B(PAAC), \\ PABC &\rightarrow B(PAA) \\ PABC &\rightarrow BC(PAA)C \quad \text{are proper rules.} \end{aligned}$$

- (ii)  $\lambda P$  is called *proper* if all its  $P$ -rules are proper.

3.4.4. REMARK. Every definable extension  $\lambda P$  can be 'embedded' in a proper definable extension  $(\lambda P)'$ , as follows. If  $\lambda P$  contains e.g. the improper rule  $PABC \rightarrow B(PAA)C$  then one replaces this rule simply by the proper rule  $PAB \rightarrow B(PAA)$ . Thus we obtain a proper version  $(\lambda P)'$  of  $\lambda P$ , in which we have the same reductions as in  $\lambda P$  plus some more (such as  $Pab \rightarrow b(Paa)$ , a contraction not allowed in  $\lambda P$ ).

3.4.5. PROPOSITION. For a proper definable extension  $\lambda P$  of  $\lambda$ -calculus there is a natural (or 'canonical') concept of descendants: namely, every definition of  $\lambda P$  into  $\lambda$  (by means of defining reductions  $\mathcal{R}_i$  for the  $P_i \in P$  as in Remark 1.11.2) induces the same descendant concept in  $\lambda P$ .

Moreover, this canonical concept of descendants coincides with the one in Def. 3.4.1.

PROOF. Consider a rule  $PA_1 \dots A_n \rightarrow Q$  and a defining reduction  $\mathcal{R} = PA_1 \dots A_n \twoheadrightarrow Q'$  for some  $\lambda$ -term  $P$ . Then it is simple to prove (using the properness condition) that  $\mathcal{R}$  must be in fact

$$\begin{aligned} \mathcal{R} = PA_1 \dots A_n &\twoheadrightarrow (\lambda x_1.M_1)A_1 \dots A_n \twoheadrightarrow (\lambda x_2.M_2)A_2 \dots A_n \twoheadrightarrow \\ &\twoheadrightarrow \dots \twoheadrightarrow (\lambda x_n.M_n)A_n \twoheadrightarrow Q'. \end{aligned}$$



(So all  $A_i$  ( $i = 1, \dots, n$ ) are 'eaten'.)

Hence (by Remark 3.3.1.(i)) none of the terms  $P, PA_1, PA_1A_2, \dots, PA_1 \dots A_n$  has a descendant in  $\Omega'$ . Since this holds for all the  $P_i$ -reduction rules ( $P_i \in P$ ) and all defining reductions  $\mathcal{R}_i$  for them, the *induced* concept of descendant is therefore the same as the one in Def. 3.4.1.  $\square$

3.4.6. REMARK. The properness condition is necessary; for consider the improper rule  $PABC \rightarrow PB(PAA)C$  and now define the  $\lambda$ -term  $P$  such that  $PAB \twoheadrightarrow PB(PAA)$  for all  $A, B$ , then in the reduction  $PABC \twoheadrightarrow PB(PAA)C$  we have  $PABC \dashrightarrow PB(PAA)C$ . So the induced descendant concept does not satisfy the property that a  $P$ -redex after its contraction leaves no residuals (and we will need that property later on, to prove the theorem 'Finite Developments' for  $\lambda P$ ).

3.4.7. EXAMPLE. Consider in CL the rule  $((SA)B)C \rightarrow ((AC)(BC))$ . According to our definition 3.4.1, the subterms  $(AC)$ ,  $(BC)$  and  $((AC)(BC))$  in the RHS have no ancestors in the LHS, or equivalently, the displayed brackets in the RHS have no ancestors in the LHS.

The following defining reduction in  $\lambda$  for the  $S$ -rule shows why this is so: the brackets in the RHS descend really from brackets "hidden" in the  $S$ :

$$\begin{array}{r}
 (( ( S A ) B ) C ) \equiv \\
 0 \ 1 \ 2 \quad \quad 2 \quad 1 \quad 0 \\
 \\
 ( ( ( ( \lambda a ( \lambda b ( \lambda c ( ( ac ) (bc ) ) ) ) ) A ) B ) C ) \longrightarrow \\
 0 \ 1 \ 2 \ 3 \quad 5 \quad 6 \quad 7 \ 8 \quad 8 \ 9 \ 9 \ 7 \ 6 \ 5 \ 3 \quad 2 \quad 1 \quad 0 \\
 \\
 ( ( \quad ( \lambda b ( \lambda c ( ( Ac ) (bc ) ) ) ) \quad B ) C ) \longrightarrow \\
 0 \ 1 \quad \quad 5 \quad 6 \quad 7 \ 8 \quad 8 \ 9 \ 9 \ 7 \ 6 \ 5 \quad \quad 1 \quad 0 \\
 \\
 ( \quad ( \lambda c ( ( Ac ) (Bc ) ) ) \quad C ) \longrightarrow \\
 0 \quad \quad \quad 6 \quad 7 \ 8 \quad 8 \ 9 \ 9 \ 7 \ 6 \quad \quad \quad 0 \\
 \\
 \quad \quad \quad \quad ( ( AC ) (BC ) ) \\
 \quad \quad \quad \quad 7 \ 8 \quad 8 \ 9 \ 9 \ 7
 \end{array}$$

Hence the subterms 7, 8, 9 have no ancestors.

### 3.5. UNDERLINING

(i) Consider  $\lambda_A$ -calculus as in Definition 3.1 and let  $A = \{0,1\}$ . A notational variant of this reduction system

$\lambda_{\{0,1\}} = \langle \text{Ter}(\lambda_{\{0,1\}}), \xrightarrow{B_{\{0,1\}}} \rangle$  is obtained by *underlining* the subterms having label 1 (and only those).

So instead of  $((\lambda x(x_1 x_0))_1 (y_0 z_1)_0)_1$  we write

$$\frac{((\lambda x(\underline{xx}))(\underline{yz}))}{\underline{\quad}}$$

and this redex has a contractum:

$$\frac{((\underline{yz})(\underline{yz}))}{\underline{\quad}}$$

Let  $\lambda^* = \langle \text{Ter}(\lambda^*), \frac{\quad}{\beta^*} \rangle$  be this reduction system. Note that there are infinite reductions, e.g.  $(\lambda x.\underline{xx})(\lambda x.\underline{xx})$   $\beta^*$ -reduces to itself.

- (ii) Now we restrict  $\text{Ter}(\lambda^*)$  to the subset of terms where *only*  $\beta$ -redexes may be underlined. Let the resulting reduction system be

$$\lambda^{**} = \langle \text{Ter}(\lambda^{**}), \frac{\quad}{\beta^{**}} \rangle,$$

where  $\beta^{**}$  is the restriction of  $\beta^*$  to  $\text{Ter}(\lambda^{**}) \subseteq \text{Ter}(\lambda^*)$ .

- (iii) Moreover we add a notational simplification to  $\lambda^{**}$ , namely 'reduced underlining'. Since a  $\beta$ -redex is determined by its head- $\lambda$ , it suffices to underline only that  $\lambda$  instead of the whole redex.

The resulting system will be called  $\underline{\lambda} = \langle \text{Ter}(\underline{\lambda}), \frac{\quad}{\underline{\beta}} \rangle$ , in words: *underlined  $\lambda$ -calculus*, *underlined  $\beta$ -reduction*.

Instead of ' $\underline{\lambda}$ -calculus' we will also say: ' $\underline{\lambda}\underline{\beta}$ -calculus'.

We will not need the auxiliary systems  $\lambda^*$ ,  $\lambda^{**}$  anymore.

An example of a reduction in  $\underline{\lambda}$ :

$$\begin{aligned} & (\underline{\lambda a}.aa)[(\underline{\lambda b}.b)(\lambda c.cc)] \xrightarrow{\underline{\beta}} (\underline{\lambda b}.b)(\lambda c.cc)[(\underline{\lambda b}.b)(\lambda c.cc)] \\ & \xrightarrow{\underline{\beta}} \xrightarrow{\underline{\beta}} (\lambda c.cc)(\lambda c.cc), \quad \text{a } \underline{\beta}\text{-normal form.} \end{aligned}$$

- (iv) Analogous to  $\underline{\lambda}$  we define  $\underline{\lambda P}$ , the underlined version of a definable extension  $\lambda P$  of  $\lambda$ . The definition is straightforward and will be left to the reader. Here also we may employ reduced underlining: instead of  $\underline{PABC}$ , say, write only  $\underline{P}ABC$ .

### 3.6. DEVELOPMENTS

Reductions in  $\underline{\lambda}$  or  $\underline{\lambda P}$  give rise to reductions in  $\lambda$  or  $\lambda P$ , by erasing the underlinings. Reductions in  $\lambda$  or  $\lambda P$  which can be obtained in this way, will be called *developments*.

In the next section (4) we will prove that  $\underline{\lambda} \models \text{SN}$ ; or in other words,

all developments are finite.

### 3.7. HYLAND-WADSWORTH LABELS

3.7.0. Again we consider  $\text{Ter}(\lambda_{\mathbb{N}})$ . But now we define a reduction totally different from  $\xrightarrow{\beta_{\mathbb{N}}}$  as introduced in 3.2; let us call it  $\xrightarrow{\beta_{\text{HW}}}$ . It is introduced by HYLAND [76] and WADSWORTH [76] and can be considered as a syntactic counterpart of projection in Scott's models  $D_{\infty}$ ,  $P_{\infty}$  of the  $\lambda$ -calculus; but we will not go into that (for references, see e.g. BARENDREGT [77]).

Whereas in 3.2 the labels served merely for tracing the descendants in a reduction, now they play a role of their own.  $\beta_{\text{HW}}$ -reduction can be conveniently defined (as in BARENDREGT [77], but without  $\Omega$ ) by admitting sub-terms which have *multiple* labels, e.g.  $((M^a)^b)^c$ ; possibly no label at all.

3.7.1.  $\text{Ter}(\lambda^{\text{HW}})$ , the set of  $\lambda^{\text{HW}}$ -terms, is defined by

- (i)  $x, y, z, \dots \in \text{Ter}(\lambda^{\text{HW}})$
- (ii)  $A, B \in \text{Ter}(\lambda^{\text{HW}}) \Rightarrow (AB) \in \text{Ter}(\lambda^{\text{HW}})$
- (iii)  $A \in \text{Ter}(\lambda^{\text{HW}}) \Rightarrow (\lambda x.A) \in \text{Ter}(\lambda^{\text{HW}})$
- (iv)  $A \in \text{Ter}(\lambda^{\text{HW}}) \Rightarrow A^n \in \text{Ter}(\lambda^{\text{HW}})$  for all  $n \in \mathbb{N}$ .

The multiple labeling is only an auxiliary device; when possible the following simplifying rule will be applied:

$$(M^n)^m \longrightarrow M^{(n,m)}$$

for all  $M \in \text{Ter}(\lambda^{\text{HW}})$  and  $n, m \in \mathbb{N}$ . Here  $(n, m) = \text{minimum } \{n, m\}$ .

$\beta_{\text{HW}}$ -reduction is now defined by

$$(\lambda x.A)^n_B \xrightarrow{\beta_{\text{HW}}} [x := B^{n-1}]_A^{n-1}$$

for all  $A, B \in \text{Ter}(\lambda^{\text{HW}})$  and  $n > 0$ .

Here  $n$  is called the *degree* of the redex on the LHS. Note that reduction is only allowed for redexes of *positive* degree.

Furthermore, the substitution operator used in the previous definition,  $\sigma = [x := A]$ , is defined as follows:

- (i)  $\sigma x = A, \sigma y = y$  for  $x \neq y$
- (ii)  $\sigma(AB) = (\sigma A)(\sigma B)$
- (iii)  $\sigma(\lambda y.A) = \lambda y.\sigma A$
- (iv)  $\sigma(A^n) = (\sigma A)^n$ .

Note the difference with substitution in 3.2:

there  $[x := (\dots)^b] x^a = (\dots)^b$ ,  
 here  $[x := (\dots)^n] x^m = ((\dots)^n)^m \longrightarrow (\dots)^{(n,m)}$ .

For an example of a  $\beta_{HW}$ -reduction see the figure on p.26.

3.7.2. REMARKS. (i) In section 7 we will prove by an 'interpretation' of  $\lambda$ -calculus into  $\lambda I$ -calculus that  $\lambda^{HW} \models SN$  (i.e.  $\beta_{HW}$ -reduction is strongly normalizing).

(Notation: we borrow the sign ' $\models$ ' from model theory, meaning: '... has the property...' or: '...satisfies...'.)

(ii) *Creation of redexes.* One of the key facts in the proof of (i) is that a redex  $R$  of degree  $d$  can only create new redexes of degree  $< d$ .

Here we say that in the step  $M_0 \xrightarrow{R} M_1$  a redex  $R_1 \subseteq M_1$  is created by (the contraction of)  $R$  iff no redex  $R_0 \subseteq M_0$  descends to  $R_1$ . In LÉVY [74,78] it is worked out when such creations happen. There are the following three cases:

- I.  $\dots[(\lambda x.C[xB])(\lambda y.A)]\dots \longrightarrow \dots[C^\sigma[(\lambda y.A)B^\sigma]]\dots$
- II.  $\dots[(\lambda x.x)(\lambda y.A)B]\dots \longrightarrow \dots[(\lambda y.A)B]\dots$
- III.  $\dots[(\lambda x.\lambda y.A)CB]\dots \longrightarrow \dots[(\lambda y.A^{\sigma'})B]\dots$

where  $\sigma$  is the substitution  $[x := \lambda y.A]$ ,  $\sigma'$  is  $[x := C]$  and  $C[ ]$ ,  $\dots[ ]\dots$  are arbitrary contexts. ( $B^\sigma$ ,  $C^\sigma[ ]$  stands for  $\sigma(B)$ ,  $\sigma(C[ ])$ .)

It is a matter of routine to verify that the degree of the created  $\lambda y$  redex in the RHS is indeed less than the degree of the  $\lambda x$  redex in the LHS. (The first occurrence of  $n-1$  in  $(\lambda x.A)^n B \longrightarrow [x := B^{n-1}]A^{n-1}$  causes this decreasing effect for creation of type I, II; the second for type III.)

EXAMPLE.

$$\begin{aligned}
 & ((\lambda x.(x^9_I)^{11,7} (\lambda y.A)^8)^{10}) \xrightarrow{\beta_{HW}} \\
 & ((((((\lambda y.A)^8)^{6,9}_I)^{11,6,10})) \longrightarrow ((\lambda y.A)^{(8,6,9)}_I)^{(11,6,10)} \equiv \\
 & ((\lambda y.A)^6_I)^6.
 \end{aligned}$$

FIGURE

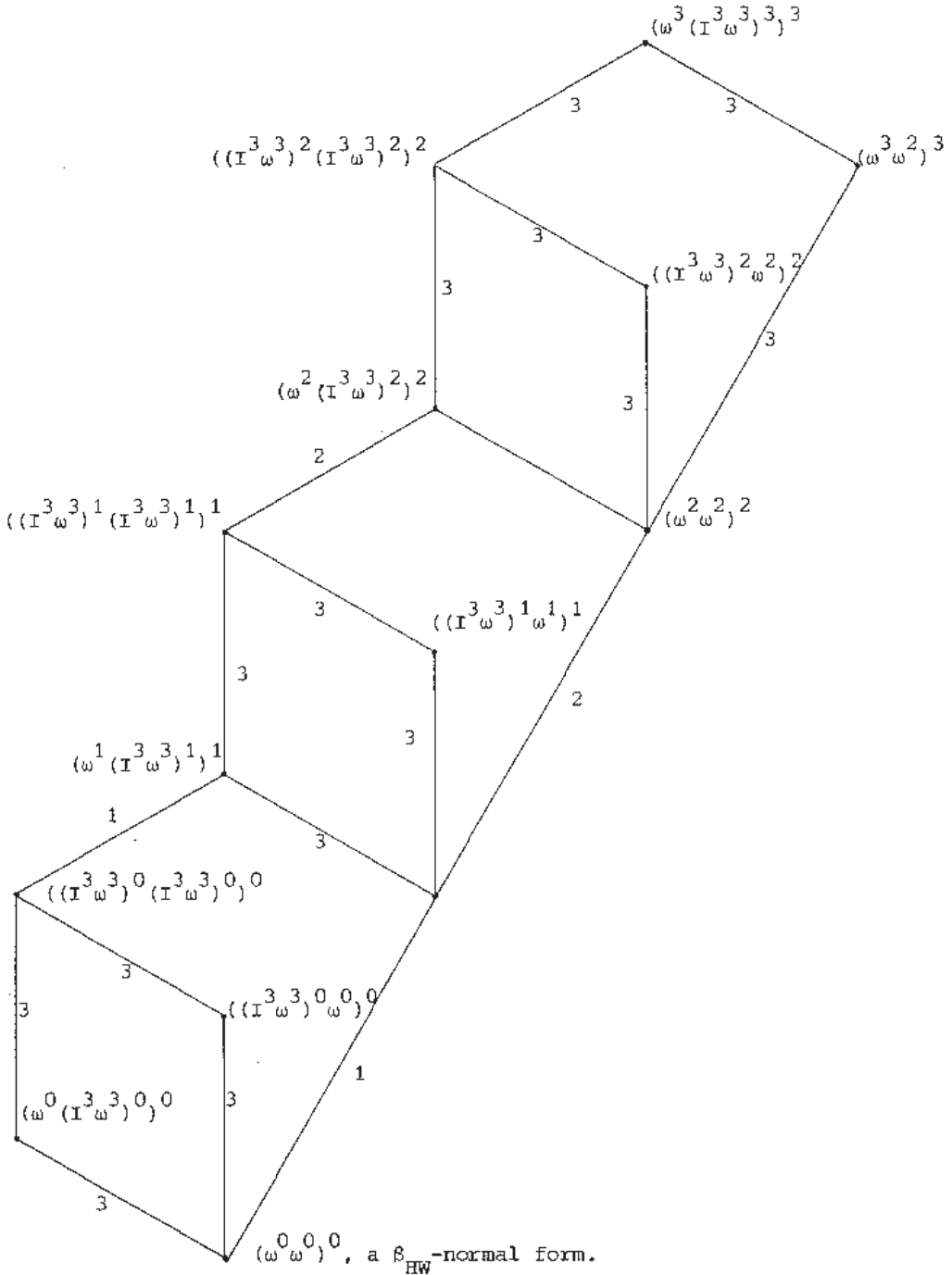

The  $\beta_{HW}$ -reduction graph of  $(\omega^3 (I^3 \omega^3)^3)^3$ , where  $\omega \equiv (\lambda x. (x^3 x^3)^3)$ .

All arrows are pointing downwards. At each arrow the degree of the contracted redex is indicated.

(iii) On the other hand, the redexes  $R'$  which descend from a redex  $R$  in a  $\beta_{HW}$ -reduction  $\mathcal{R} = M \longrightarrow \dots \longrightarrow M'$

$$\begin{array}{ccc} & & \\ & \cup & \\ & & \\ & & \\ & \cup & \\ & & \\ R \longrightarrow & \dots \longrightarrow & R' \end{array}$$

have the same degree as  $R$ .

For a verification of (ii) and (iii) see LÉVY [78], p.29-32.

(iv) The system  $\underline{\lambda}$  in 3.5 can also be obtained from  $\lambda^{HW}$ . For, consider terms  $M$  in  $\text{Ter}(\lambda^{HW})$  such that some redexes  $\subseteq M$  have label 1 and all the other subterms in  $M$  have label 0; let an underlined term  $\epsilon \text{Ter}(\underline{\lambda})$  correspond to such  $M$  as in 3.5. Then  $\beta_{HW}$ -reduction of such terms  $M$  corresponds precisely to a  $\underline{\beta}$ -reduction of  $M$ .

3.8. *Typed  $\lambda$ -calculus* or  $\lambda^\tau$ -calculus is obtained as follows. The labels are called 'types' here and the set of types  $\tau$  is defined inductively by

- (i)  $0 \in \tau$
- (ii)  $\alpha, \beta \in \tau \Rightarrow (\alpha \rightarrow \beta) \in \tau$ .

Now we do not work with the whole set  $\text{Ter}(\lambda^\tau)$  as defined in 3.1, but with a subset  $\mathcal{T}$  of terms subject to the restriction that types must match in the sense of the following inductive definition:

- (i)  $x^\alpha \in \mathcal{T}$  for all  $x \in \text{VAR}$  and  $\alpha \in \tau$
- (ii)  $A^{\alpha \rightarrow \beta} \in \mathcal{T} \ \& \ B^\alpha \in \mathcal{T} \Rightarrow (A^{\alpha \rightarrow \beta} B^\alpha)^\beta \in \mathcal{T}$
- (iii)  $A^\beta \in \mathcal{T} \Rightarrow (\lambda x^\alpha . A^\beta)^{\alpha \rightarrow \beta} \in \mathcal{T}$ .

### 3.9. LEVY'S LABELS

Now we turn to a labeled  $\lambda$ -calculus introduced in J.J. LÉVY [75,78]. It is a common generalization of all the labeled  $\lambda$ -calculi we have dealt with so far. We will refer to it as  $\lambda^L$ -calculus. It is closely connected with the concept of *equivalence of reductions* (also introduced in LÉVY [78]), a concept we will comment on later.

The set  $L$  of Lévy-labels is defined inductively as follows. Let  $L'$  be an infinite set of symbols,  $L' = \{a, b, c, \dots\}$ . Then define

- (i)  $L' \subseteq L$
- (ii)  $\alpha, \beta \in L \Rightarrow \alpha\beta \in L$
- (iii)  $\alpha \in L \Rightarrow \underline{\alpha} \in L$ .

Here  $\alpha\beta$  is the concatenation of  $\alpha$  and  $\beta$ , without brackets.

The definition of the set  $\text{Ter}(\lambda^L)$  of  $\lambda^L$ -terms and of substitution in  $\lambda^L$  is mutatis mutandis (i.e. replace HW by L and  $n \in \mathbb{N}$  by  $\alpha \in L$ ) the same as for  $\lambda^{\text{HW}}$  in 3.7.

Again we simplify multiple labelings whenever possible, now using the rule:

$$(M^\alpha)^\beta \longrightarrow M^{\alpha\beta}$$

for all  $M \in \lambda^L$  and  $\alpha, \beta \in L$ :

$\beta_L$ -reduction is defined as

$$(\lambda x.A)^\alpha B \xrightarrow{\beta_L} [x := B^\alpha]A^\alpha$$

for all  $A, B \in \text{Ter}(\lambda^L)$  and  $\alpha \in L$ . As before,  $\alpha$  is called the *degree* of the displayed redex. Also as before, it is easily checked that during a reduction the residuals of a redex R keep the same degree as R. (See LÉVY [78].)

There are two differences in our definition as compared to LÉVY [75,78]; there underlining and 'overlining' are used (but later Lévy remarked that the latter is not necessary) and secondly, our labels are the mirror image of those in LÉVY [75,78].

3.9.1. EXAMPLES.

(1)  $((\lambda x.(x^a I)^b)^c (\lambda y.A)^d)^e \xrightarrow{\beta_L} \twoheadrightarrow ((\lambda y.A)^{\overline{dca}I})^{\underline{bce}}$  (cf. the similar example for  $\lambda^{\text{HW}}$  above.)

(2) This example is taken from LÉVY [75] but in our revised notation:

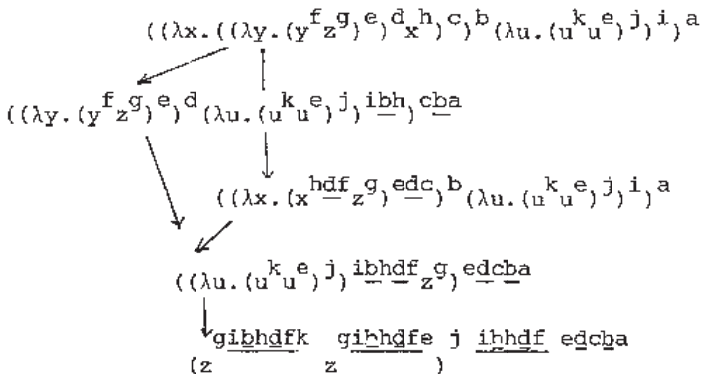

The following remarks are also essentially due to LÉVY [75,78].

3.9.2. REMARKS. (1) There is a simple homomorphism from  $\lambda^L$  to  $\lambda_A$  (as in 3.1). Namely, take  $L' = A$  and given a  $\lambda^L$ -term  $M$ , erase all but the first symbol of every label  $\alpha$  in  $M$ . It is easy to check that this procedure transforms  $\beta_L$ -reductions in  $\beta_L$ -reductions in the sense of 3.1. (Cfr. the examples just given.)

(2)  $\lambda^L$  is not SN, but certain restricted forms of it are.

Let  $P$  be a predicate on  $L$  which is *bounded* in the sense that the labels  $\alpha$  for which  $P(\alpha)$  holds, are bounded in *height*, i.e.

$$\exists n \in \mathbb{N} \quad \forall \alpha \in L(P(\alpha) \Rightarrow h(\alpha) \leq n).$$

Here the height  $h(\alpha)$  is defined by

- (i)  $h(a) = 0$  for  $a \in L'$
- (ii)  $h(\alpha\beta) = \max\{h(\alpha), h(\beta)\}$
- (iii)  $h(\underline{\alpha}) = h(\alpha) + 1$ .

Now restrict  $\beta_L$ -reduction such that contraction of a redex with degree  $\alpha$  is only allowed if  $P(\alpha)$ . Denote the resulting system by  $\lambda^{L,P}$ , or in case  $P(\alpha) \Leftrightarrow h(\alpha) \leq n$ , simply by  $\lambda^{L,n}$ .

Now we have  $\lambda^{L,P} \models$  SN for bounded  $P$ . See LÉVY [75,78] for a proof; in section 8 we give an alternative proof.

(3) There is also a "homomorphism" from  $\lambda^L$  to  $\lambda^{HW}$  but not as direct as the previous one. Let us describe it as follows.

Firstly, define  $\lambda_{\mathbb{Z}}^{HW}$  just as  $\lambda^{HW}$  but now allowing also negative labels and dropping the restriction that only redexes of positive degree may be contracted.

Secondly, let  $f: L \rightarrow \mathbb{Z}$  satisfy

- (i)  $f(a) \in \mathbb{N}$  for all  $a \in L'$
- (ii)  $f(\alpha\beta) = \min\{f(\alpha), f(\beta)\}$
- (iii)  $f(\underline{\alpha}) = f(\alpha) - 1$ .

Note that  $h(\alpha)$  and  $f(\alpha)$  are, roughly speaking, opposite in sign:

(\*)  $m - h(\alpha) \leq f(\alpha) \leq M - h(\alpha)$ , where  $m = \min \{f(a_i) \mid a_i \in \alpha\}$  and  $M = \max \{f(a_i) \mid a_i \in \alpha\}$ . We leave the proof of (\*) to the reader.

(\*\*) Now we have for every  $f$  satisfying (i), (ii), (iii) above a homomorphism from  $\lambda^L$  to  $\lambda_{\mathbb{Z}}^{HW}$ , namely by replacing every label in a reduction in  $\lambda^L$  by  $f(\alpha)$ .



Moreover one easily proves:

3.9.3. PROPOSITION. *The following are equivalent:*

- (i)  $\lambda^{\text{HW}} \models \text{SN}$
- (ii) *In every infinite reduction in  $\lambda_{\mathbb{Z}}^{\text{HW}}$  a redex of degree  $\leq 0$  is contracted.*
- (iii) *In every infinite reduction in  $\lambda_{\mathbb{Z}}^{\text{HW}}$  the set of degrees of contracted redexes is unbounded from below.*
- (iv) *In every infinite reduction in  $\lambda^{\mathbb{L}}$  the set  $\{h(\alpha) \mid \alpha \text{ is degree of a contracted redex}\}$  is unbounded from above.*
- (v)  $\lambda^{\mathbb{L},n} \models \text{SN}$  for all  $n \in \mathbb{N}$ .
- (vi)  $\lambda^{\mathbb{L},P} \models \text{SN}$  for all bounded predicates  $P$ .

PROOF. By using (\*), (\*\*) in the proof of (iii)  $\Leftrightarrow$  (iv) and noticing for (ii)  $\Rightarrow$  (iii) that given a reduction  $\mathcal{R}$  in  $\lambda_{\mathbb{Z}}^{\text{HW}}$ , the reduction  $\mathcal{R}'$  obtained by adding a fixed  $n \in \mathbb{N}$  to all the labels in  $\mathcal{R}$ , is again a reduction in  $\lambda_{\mathbb{Z}}^{\text{HW}}$ .  $\square$

The figure on p.31 summarizes this section (without definable extensions).

## 4. FINITE DEVELOPMENTS

### 4.0. INTRODUCTION

A  $\underline{\beta}$ -reduction is as we remarked in section 3, a special kind of  $\beta_{\text{HW}}$ -reduction. Since  $\beta_{\text{HW}}$ -reduction has the property SN (as we will prove in section 8),  $\underline{\beta}$ -reductions are therefore strongly normalizing too. This is the theorem of 'Finite Developments' (FD).

However, we will give another proof of FD in this section, because:

- (a) it is much simpler than the proof of  $\lambda^{\text{HW}} \models \text{SN}$ ,
- (b) it generalizes without effort to FD for some extensions of  $\lambda$ -calculus such as  $\lambda\beta\eta\Omega$ -calculus (see BARENDREGT, BERGSTRA, KLOP, VOLKEN [76]),
- (c) it generalizes at once to FD for definable extensions (hence also for CL), and
- (d) our proof strategy is such that we need FD to prove  $\lambda^{\text{HW}} \models \text{SN}$  (see p.32):

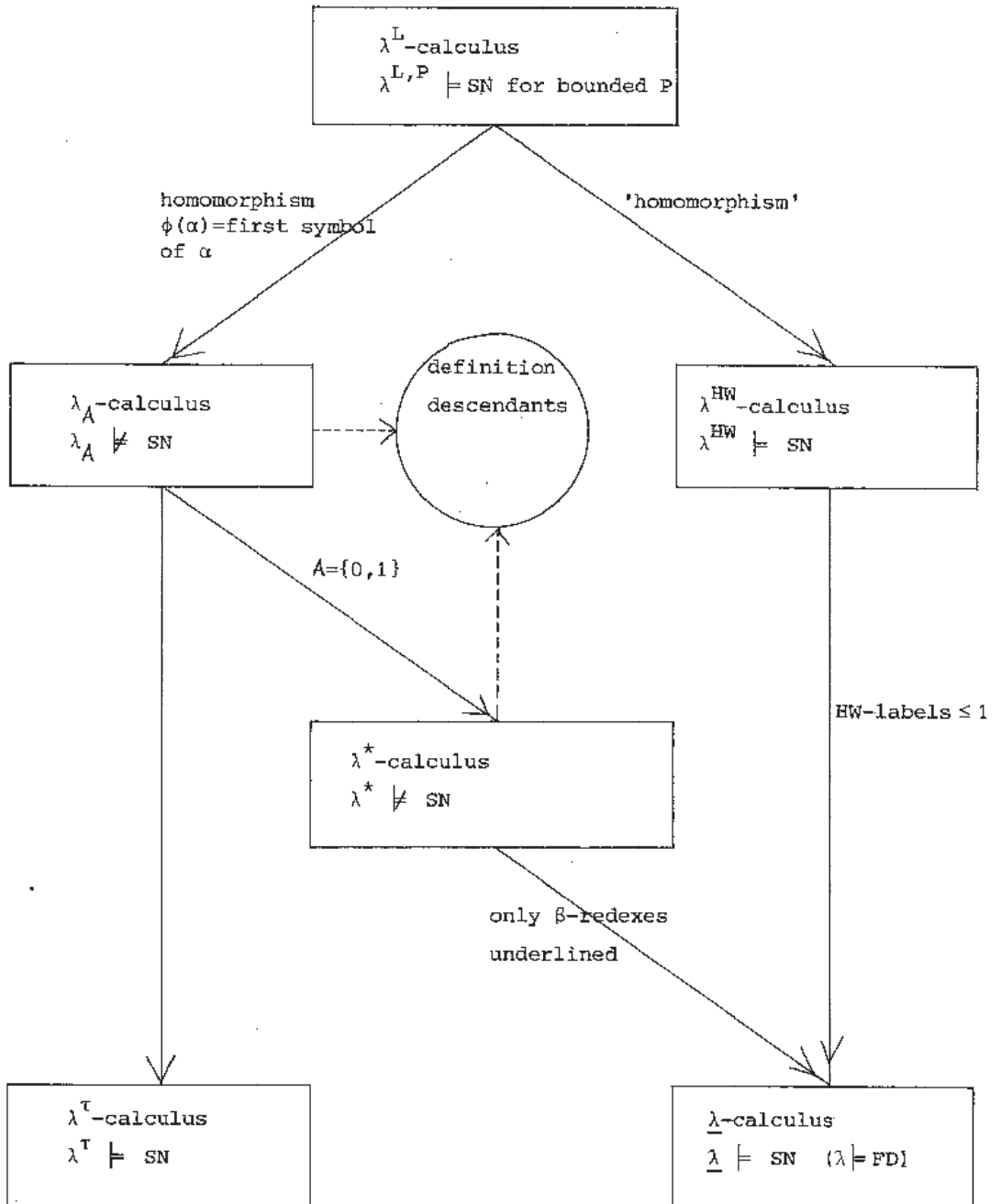

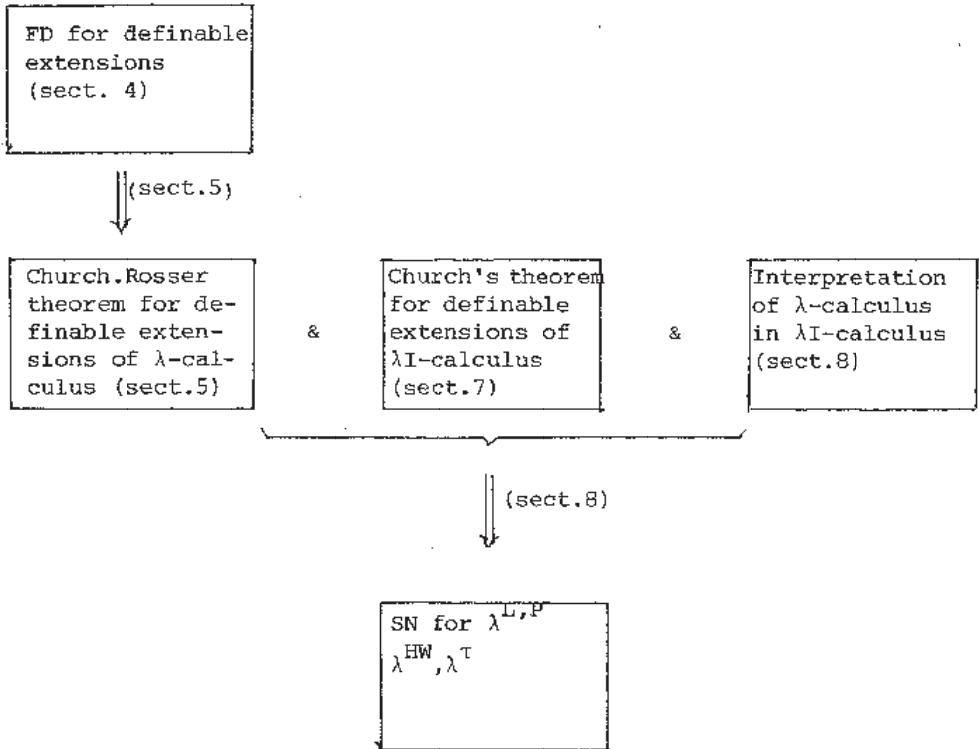

#### 4.1. PRELIMINARY REMARKS

(i) If  $\Sigma$  is a 'reduction system', such as  $\lambda$ ,  $\lambda I$ ,  $\lambda P$ , or CL (in Chapter II we will consider a general concept of 'reduction system') then  $\underline{\Sigma}$  denotes the corresponding *underlined* reduction system, as defined in 3.5.

(ii) We remind the reader that an essential feature of  $\underline{\Sigma}$  is that in  $\underline{\Sigma}$ -reductions there is no creation of  $\underline{\Sigma}$ -redexes; e.g. in a  $\underline{\lambda\beta}$ -reduction  $\mathcal{R} = M_0 \xrightarrow[\underline{\beta}]{R_0} M_1 \xrightarrow[\underline{\beta}]{R_1} \dots$  every contracted  $\underline{\beta}$ -redex  $R_i \equiv (\underline{\lambda}x.A_i)B_i$  ( $i = 0, 1, \dots$ ) is a descendant of some  $\underline{\beta}$ -redex in  $M_0$ . (There can be  $\beta$ -redexes created, but no  $\underline{\beta}$ -redexes.)

(iii) Let  $\mathcal{R}$  be a  $\underline{\Sigma}$ -reduction and  $\mathcal{R}'$  be the corresponding  $\Sigma$ -reduction, obtained by erasing the underlining in  $\mathcal{R}$ . Then  $\mathcal{R}$  is called a ( $\Sigma$ -) *development*.

The theorem that we will prove now, asserts that for  $\Sigma = \lambda, \lambda I, \lambda P, CL$  all *developments* are *finite*.

Notation:  $\Sigma \models FD$ . Note that by definition, this is equivalent to:  $\underline{\Sigma} \models SN$ .

(iv) The method that is going to be used in the proof below is taken from BARENDREGT, BERGSTRA, KLOP, VOLKEN [76]. Given a development

$\mathcal{R} = M_0 \longrightarrow M_1 \longrightarrow \dots$ , to each symbol  $s \in M_0$  a *weight*  $|s| \in \mathbb{N}$  is associated. During the reduction  $\mathcal{R}$ , every symbol keeps its weight unchanged. The assignment of weights is such that the total weight  $|M_i|$  ( $:= \sum_{s \in M_i} |s|$ ) of the  $M_i \in \mathcal{R}$  ( $i = 0, 1, \dots$ ) decreases:

$$|M_0| > |M_1| > \dots$$

Before giving the actual proof, we need some definitions. Throughout the proof,  $\Sigma$  is a definable extension of  $\lambda$ -calculus, having  $P$  as set of constants.

4.1.1. DEFINITION. Let  $P \in P$  have the reduction rule:

$$PA_1 \dots A_n \longrightarrow Q(A_1, \dots, A_n).$$

- (i) The *multiplicity* of  $A_i$  ( $i = 1, \dots, n$ ) in  $Q$ ,  $\text{mult}(A_i)$ , is the number of occurrences of  $A_i$  in  $Q$ .
- (ii)  $m(P) = \max\{\text{mult}(A_i) \mid i = 1, \dots, n\}$ .
- (iii)  $m = \max\{m(P) \mid P \in P\} + 1$ .

4.1.2. EXAMPLE. Let  $\Sigma$  be  $\lambda + \text{CL} + \{PABC \longrightarrow P(AAACC)BB\}$ . So  $P = \{I, K, S, P\}$ ,  $m(I) = 1$ ,  $m(K) = 1$ ,  $m(S) = 2$ ,  $m(P) = 3$  and  $m = 4$ . This will be our working example during the proof.

4.1.3. DEFINITION. (i) Let  $\underline{\Sigma}$  be the underlined version of  $\Sigma$ .

(In our example,  $\underline{\Sigma} = \underline{\lambda} + \underline{\text{CL}} + \{\underline{P}ABC \longrightarrow P(\underline{A}\underline{A}\underline{A}\underline{C}\underline{C})\underline{B}\underline{B}\}$ ). The set of constants  $\underline{P}$  of  $\underline{\Sigma}$  is  $\{I, \underline{I}, K, \underline{K}, S, \underline{S}, P, \underline{P}\}$  and the reduction rules are

$$\begin{aligned} (\underline{\lambda}x.A(x))B &\longrightarrow A(B) \\ \underline{I}A &\longrightarrow A, \underline{K}AB &\longrightarrow A, \underline{S}ABC &\longrightarrow AC(BC) \\ \underline{P}ABC &\longrightarrow P(\underline{A}\underline{A}\underline{A}\underline{C}\underline{C})\underline{B}\underline{B}. \end{aligned}$$

(ii)  $\underline{\Sigma}_w$  is defined as follows.

$\text{Ter}(\underline{\Sigma}_w)$  is obtained from  $\text{Ter}(\underline{\Sigma})$  by adding natural numbers as labels to some of the symbols of  $\underline{\Sigma}$ -terms. These labels will be called *weights* and will be written as superscripts.

Reduction in  $\underline{\Sigma}_w$  is just  $\underline{\Sigma}$ -reduction where the weights are taken along, in the sense of Definition 3.2 (i.e. each symbol keeps its own weight during

the reduction and the presence of weights does not affect the allowed reductions.)

#### 4.1.4. EXAMPLE.

$$\begin{array}{l}
 M_1 \equiv (\underline{\lambda}x.x^6 x^7)(\underline{P}^8 Y^2 PPY^3) \\
 \downarrow \beta \\
 M_2 \equiv \underline{P}^8 Y^2 PPY^3 (\underline{P}^8 Y^2 PPY^3) \\
 \downarrow P \\
 M_3 \equiv P(Y^2 Y^2 Y^2 PP)Y^3 Y^3 (\underline{P}^8 Y^2 PPY^3).
 \end{array}$$

#### 4.1.5. NOTATION AND DEFINITION.

- (i)  $\Sigma_W$ -terms will also be written as  $M^I$  where  $M$  is a  $\Sigma$ -term and  $I$  is  $M$ 's weight assignment (so  $I$  is a partial map from  $\text{Symb}(M)$  to  $\mathbf{N}$ ).
- (ii) if  $s \in M$ , then  $|s| = I(s)$ , the weight of  $s$ . We put  $|s| = 0$  if  $s$  has no weight ( $I(s)$  undefined).
- (iii) if  $W \subseteq M$  is a *subword* of  $M$  (i.e. a sequence of consecutive symbols in  $M$ ) then

$$|W| = \sum_{s \in W} |s|.$$

E.g. in the example above  $|M_1| = 26$  and  $|Y^2 PPY^3| = 5$ .

#### 4.1.6. DEFINITION.

Let  $M^I$  be a  $\Sigma_W$ -term.

- (i) Let  $R \subseteq M$  be a  $\beta$ -redex. Then  $R \equiv (\underline{\lambda}x.A)B$  is called *good w.r.t.  $I$*  iff  $|x| > |B|$  for every occurrence of  $x$  in  $A$ .
- (ii) Let  $R \subseteq M$  be a  $\underline{P}$ -redex for some  $P \in P$ . Then  $R \equiv \underline{P}A_1 \dots A_n$  is called *good w.r.t.  $I$*  iff  $|P| > m|A_1 \dots A_n|$  where  $m$  is as in Definition 4.1.1(iii).
- (iii)  $M^I$  is called *good* if every ( $\beta$ - or  $\underline{P}$ -)redex in  $M$  is good w.r.t.  $I$ .

4.1.7. EXAMPLE. In example 4.1.4, the  $\beta$ -redex nor the  $\underline{P}$ -redex in  $M_1$  is good w.r.t. the displayed weight assignment.

However,  $M_4 \equiv (\underline{\lambda}x.x^{24} x^{30})(\underline{P}^{18} Y^2 PPY^3)$  is good.

4.1.8. PROPOSITION. Let  $M \in \text{Ter}(\Sigma)$ . Then there is a good  $M^I \in \text{Ter}(\Sigma_W)$ .

PROOF. Let  $M \equiv s_\ell \dots s_1 \dots s_2 s_1 s_0$  where  $s_i$  is the  $i$ -th symbol from the right, and define the weight assignment  $I$  by  $I(s_i) = |s_i| = (m+1)^i$ , for  $i = 0, \dots, \ell$ . Then, since

$$\frac{(m+1)^{i+1} - 1}{(m+1) - 1} = 1 + (m+1) + (m+1)^2 + \dots + (m+1)^i$$

we have

$$(m+1)^{i+1} > m(1 + (m+1) + \dots + (m+1)^i).$$

So  $|s_{i+1}| > m|s_i s_{i-1} \dots s_0|$ , hence a fortiori

- (i) every  $x$  free in  $A \subseteq (\lambda x.A)B$  is heavier than  $B$  (since  $m \geq 1$  and  $B$  is to the right of  $x$ ) and
- (ii) every  $\underline{P} \in P$  is at least  $m$  times heavier than the total of its arguments  $A_1, \dots, A_n$ .

Therefore  $M^I$  is a good  $\Sigma_W$ -term.  $\square$

4.1.9. PROPOSITION. Let  $R = M_0 \longrightarrow M_1 \longrightarrow \dots$  be a  $\Sigma$ -reduction. Let  $M_0^{I_0} \in \text{Ter}(\Sigma_W)$ . Then there is a corresponding  $\Sigma_W$ -reduction  $R^{I_0} = M_0^{I_0} \longrightarrow M_1^{I_1} \longrightarrow \dots$ .

PROOF. It follows at once from the definitions that every step in  $\Sigma$  can be 'lifted' to the case where extra labels (in casu weights) are present.  $\square$

4.1.10. MAIN LEMMA.

- (i) Let  $M_1^{I_1}$  be a good  $\Sigma_W$ -term, and let  $M_0^{I_0} \longrightarrow M_1^{I_1}$  be a  $\Sigma_W$ -reduction step. Then  $M_0^{I_0}$  is a good  $\Sigma_W$ -term.
- (ii) Moreover,

$$|M_0^{I_0}| > |M_1^{I_1}|.$$

PROOF. First the easiest part of the lemma, (ii). Let  $R$  be the redex contracted in the step  $M_0^{I_0} \longrightarrow M_1^{I_1}$  and let  $R' \subseteq M_1$  be the contractum of  $R$ .

CASE 1.  $R$  is a  $\beta$ -redex. Say  $R \equiv (\lambda x \dots x \dots x)B$ . Since  $M_0^{I_0}$  is good,  $R$  is good w.r.t.  $I_0$ , i.e. every occurrence of  $x$  is heavier than  $B$ , so  $|R'| = |\dots B \dots B \dots| < |R|$ .

If there is no occurrence of  $x$ , also  $|R'| < |R|$ , since  $B$  disappears.

CASE 2.  $R$  is a  $\underline{P}$ -redex  $\underline{P}A_1 \dots A_n$ . Since  $R$  is good w.r.t.  $I_0$ ,  $|\underline{P}| > m|A_1 \dots A_n|$ . Moreover, the multiplying effect of  $\underline{P}$  is smaller than  $m$ . Therefore  $|R'| < |R|$ .

Hence

$$|M_1^{I_1}| < |M_0^{I_0}|.$$

(i) We have to show that every  $\underline{\beta}$  or  $\underline{P}$ -redex  $R_1 \subseteq M_1$  is again good w.r.t.  $I_1$ .

Let the redex  $R_0 \subseteq M_0$  be the ancestor of  $R_1$ . Clearly  $R_0$  is also an underlined redex. We will treat only the non-trivial cases.

As above  $R \subseteq M_0$  is the contracted redex, and  $R' \subseteq M_1$  its contractum.

CASE 1.  $R \subseteq R_0$ .

1.1.  $R_0$  is a  $\underline{\beta}$ -redex and the  $\underline{\beta}$ - or  $\underline{P}$ -redex  $R$  is a subterm of its argument:

$$\begin{array}{l} R_0 \equiv (\underline{\lambda}x.A)C[R] \quad \text{for some context } C[ ] \\ \downarrow \underline{\beta} \text{ or } \underline{P} \\ R_1 \equiv (\underline{\lambda}x.A)C[R']. \end{array}$$

Now  $|C[R]| > |C[R']|$ . Since  $M_0^{I_0}$  is good, for every occurrence of  $x$  in  $A$  we have  $|x| > |C[R]|$ . Hence in  $R_1$  also for every  $x$  in  $A$ :  $|x| > |C[R']|$ . So  $R_1$  is good w.r.t.  $I_1$ .

1.2.  $R_0$  is a  $\underline{P}$ -redex and  $R$  is subterm of one of its arguments:

$$\begin{array}{l} R_0 \equiv \underline{P}A_1 \dots A_j \dots A_n \quad (1 \leq j \leq n) \\ \downarrow \underline{\beta} \text{ or } \underline{P} \quad C[R] \\ R_1 \equiv \underline{P}A_1 \dots A'_j \dots A_n \\ \quad \quad \quad C[R']. \end{array}$$

A similar reasoning as in case 1.1 applies.

CASE 2.  $R_0 \subseteq R$

2.1.  $R_0$  is a  $\underline{\beta}$ -redex;  $R$  is a  $\underline{\beta}$ -redex and  $R$  substitutes something in the argument of:

$$\begin{array}{l} R \equiv [\underline{\lambda}y. \text{---} ((\underline{\lambda}x.A(y))B(y)) \text{---}]C \\ \downarrow \underline{\beta} \quad \quad \quad R_0 \\ R' \equiv \text{---} (\underline{\lambda}x.A(C))B(C) \text{---} \\ \quad \quad \quad R_1 \end{array}$$

Now in  $R$  for all  $y$  in  $A(y), B(y)$  we have  $|y| > |C|$ , hence  $|B(y)| > |B(C)|$ . Furthermore, for all  $x$  in  $A(y)$  we have  $|x| > |B(y)|$ .

Hence in  $R_1$ :  $|x| > |B(C)|$ .

So  $R_1$  is good w.r.t.  $I_1$ .

2.2.  $R_0$  is a  $\underline{P}$ -redex,  $R$  is a  $\underline{\beta}$ -redex and  $R$  substitutes something in one or more of the arguments of  $R_0$ :

$$\begin{array}{l} R \equiv [\underline{\lambda}y. \text{---} \underbrace{(PA_1(y) \dots A_n(y))}_{R_0} \text{---}]C \\ \downarrow \underline{\beta} \\ R' \equiv \text{---} \underbrace{(PA_1(C) \dots A_n(C))}_{R_1} \text{---} \end{array}$$

Here in  $R$ :  $|y| > |C|$  and  $|\underline{P}| > m|A_1(y) \dots A_n(y)|$ .

Hence in  $R'$ :  $|\underline{P}| > m|A_1(C) \dots A_n(C)|$ . So  $R_1$  is still good w.r.t.  $I_1$ .  $\square$

#### 4.1.11. THEOREM. (Finite Developments)

Let  $\Sigma$  be a definable extension of  $\lambda$ -calculus. Then  $\Sigma \models \text{FD}$  (i.e.  $\Sigma \models \text{SN}$ ).

PROOF. Let  $\mathcal{R}$  be a  $\underline{\Sigma}$ -reduction,  $\mathcal{R} = M_0 \rightarrow M_1 \rightarrow \dots$ . By Proposition 4.1.8  $M_0$  has a good weight assignment  $I_0$ . By Proposition 4.1.9  $\mathcal{R}$  can be extended to a  $\underline{\Sigma}_W$ -reduction  $M_0^{I_0} \rightarrow M_1^{I_1} \rightarrow \dots$

By Lemma 4.1.10 we have

$$|M_0^{I_0}| > |M_1^{I_1}| > \dots$$

Hence  $\mathcal{R}$  is finite.  $\square$

4.1.12. REMARK. Note that the above proof yields the following bonus: Every development of  $M \in \text{Ter}(\lambda)$  has at most  $2^m$  steps, where  $m$  is the length of  $M$  in symbols.

## 4.2. FAST DEVELOPMENTS

This concept is introduced for use in Chapter II. Instead of evaluating  $(\lambda x_1 \dots x_n. A(x_1, \dots, x_n))B_1 \dots B_n$  to  $A(B_1, \dots, B_n)$  in  $n$  steps, we can proceed faster by performing such a reduction in one step.

4.2.1. DEFINITION.  $\lambda\beta_m$ -calculus ( $m$  for 'many') is defined as  $\lambda\beta$ -calculus, but with the  $\beta$ -reduction rule replaced by the rules (for all  $n \geq 1$ )

$$\beta_n: (\lambda x_1 \dots x_n. A(x_1, \dots, x_n))B_1 \dots B_n \rightarrow A(B_1, \dots, B_n)$$



4.2.2. DEFINITION.  $\underline{\lambda\beta}_m$ , underlined  $\lambda\beta_m$ -calculus, is defined like  $\underline{\lambda\beta}$  (underlined  $\lambda\beta$ -calculus). That is:

(i) only  $\beta_n$ -redexes ( $n \geq 1$ ) may be underlined. Notation:

$R \equiv (\underline{\lambda x_1 \dots x_n} . A) B_1 \dots B_n$  is a  $\beta_n$ -redex. If here  $A \equiv \lambda y_1 \dots y_k . A'$  we may write  $R$  as  $(\underline{\lambda x_1 \dots x_n} y_1 \dots y_k . A') B_1 \dots B_n$ .

(ii) Only  $\beta_n$ -redexes ( $n \geq 1$ ) may be contracted in  $\underline{\lambda\beta}_m$ .

(iii) Reductions in  $\underline{\lambda\beta}_m$  are called 'fast developments'.

4.2.3. EXAMPLE.  $(\underline{\lambda xyz} . xxzz) IIII \xrightarrow{\beta_m} (\lambda z . IIzz) II$  is a reduction in  $\underline{\lambda\beta}_m$  to a  $\beta_m$ -normal form.

4.2.4. REMARK. The extension to  $\lambda\beta P_m$  (definable extensions of  $\lambda\beta_m$ ) and  $\underline{\lambda\beta P}_m$ , or  $\lambda P_m$  and  $\underline{\lambda P}_m$  for short, is straightforward.

4.2.5. THEOREM. (Finite fast developments)

$$\underline{\lambda P}_m \models \text{FD} \quad (\text{i.e. } \underline{\lambda P}_m \models \text{SN}).$$

PROOF. Entirely similar to 4.1.  $\square$

4.3. AN ALTERNATIVE PROOF OF FD FOR  $\lambda P$ .

4.3.0. The following proof of  $\lambda P \models \text{FD}$  is due to HYLAND [73]. We include it here (omitting some details) in order to give some extra information about developments which we need in Chapter II.

In this subsection we will omit the  $P$  of  $\lambda P$ ; the extension of the results below from  $\lambda$  to  $\lambda P$  is entirely straightforward.

4.3.1. DEFINITION. Let the 'disjointness property' (DP) be defined as follows:

For every reduction  $\mathcal{R} = M \longrightarrow \dots \longrightarrow M'$  and every subterm  $S \subseteq M$  the descendants  $S_1, \dots, S_n \subseteq M'$  ( $n \geq 0$ ) of  $S$  are pairwise disjoint.

4.3.2. REMARK.

(i)  $\lambda\beta \not\models \text{DP}$ . For, let  $S$  contain  $x$  as free variable ( $S \not\equiv x$ ) and consider

$$M \equiv (\lambda y . yy) (\lambda x . \underline{S(x)}) \longrightarrow (\lambda x . \underline{S(x)}) (\lambda x . \underline{S(x)}) \longrightarrow \underline{S(\lambda x . \underline{S(x)})} \equiv M'.$$

(ii) Trivially  $\text{CL} \models \text{DP}$ , since there is no substitution in CL.

Next we will prove that  $\lambda\beta \models DP$ , i.e. the disjointness property holds for developments  $\mathcal{R}$ . Before we do that, we show that the finiteness of developments (FD) follows almost immediately from this fact. This observation is due to Silvio Micali (personal communication).

4.3.3. LEMMA (Micali).  $\lambda\beta \models DP \Rightarrow \lambda\beta \models FD$ .

PROOF. Consider  $M \in \lambda\beta$  in which  $\lambda_0, \dots, \lambda_n$  are the head- $\lambda$ 's of the underlined redexes. We will refer to the subscripts  $0, \dots, n$  as 'colors'. Note that in  $M$  all colors are different.

Now let a development  $\mathcal{R} = M \rightarrow M' \rightarrow \dots \rightarrow M^{(k)} \rightarrow \dots$  be given. In every  $M^{(k)} \in \mathcal{R}$  we will attach superscripts to the  $\lambda_i$ -occurrences ( $i \in \{0, \dots, n\}$ ) as follows. Let  $\lambda_i$  be such an occurrence and let  $R$  be the redex having  $\lambda_i$  as head-symbol. Let  $d (=d(\lambda_i))$  be the number of different colors of  $\lambda_j$ 's contained in  $R$ . Then  $d$  is the superscript attached to  $R$ 's head-symbol  $\lambda_i$ . We will call  $d$  the 'color degree' of  $\lambda_i$ .

EXAMPLE. Let in  $M^{(k)}$  the inclusion relations between the  $\lambda_i$ -redexes be as in the figure, where  $\lambda_i \supseteq \lambda_j$  means that the  $\lambda_i$ -redex  $\supseteq$  the  $\lambda_j$ -redex.

Then the color degrees are as indicated in the figure; e.g. the one occurrence of  $\lambda_3$  has color degree 5 since the  $\lambda_3$ -redex contains the five colors  $0, 1, 2, 4, 5$ .

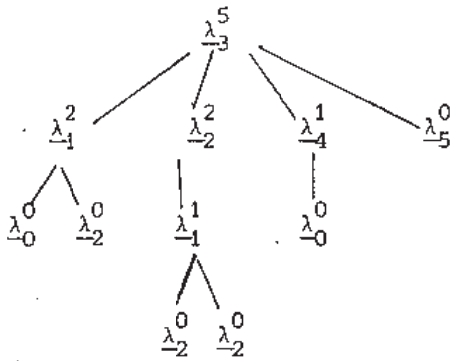

Note that by DP, a color cannot contain itself, so  $\lambda_i \supseteq \lambda_j \Rightarrow d_i < d_j$ .

Now assign to  $M^{(i)}$  the multi-set (see Def.6.4.1. below) of the color degrees +1 of all the  $\lambda_i$ -occurrences in  $M^{(k)}$ , in the example:  $\langle 6, 3, 3, 2, 1, 1, 1, 2, 1, 1, 1 \rangle$ , and consider the effect on this multi-

set of contracting, say,  $\lambda_3$ . Then in the multiset of  $M^{(k+1)}$  the number  $d(\lambda_i)+1$  ( $i = 0, 1, 2, 4, 5$ ) may increase after the contraction, they must remain  $< 6$ , regardless what happens exactly with those  $\lambda_i$ . E.g. the residuals of the  $\lambda_5$ -redex can after the contraction at most contain the four colors  $0, 1, 2, 4$  (not 5 itself by DP).

Hence by Prop.6.4.2 after the contraction we have a lower multiset w.r.t. the well-ordering there defined, and so the development  $\mathcal{R}$  must terminate.  $\square$

Now we will turn to the proof of DP for developments. In fact we obtain more. 4.4.4 - 4.4.6 are due to HYLAND [73]. (We are going into some detail, since afterwards we want to extend the results below to fast developments.)

4.3.4. DEFINITION. Let  $M \in \underline{\lambda\beta}$ . On  $\text{Sub}(M)$ , the set of subterm occurrences of  $M$ , we define the following two relations  $c^*$  and  $c^{**}$ .

(1)  $c^*$  is defined by:

- (i)  $C \subset D \Rightarrow C \subset^* D$  ( $\subset$  is the *strict* (or *proper*) subterm relation)
- (ii) if  $C, D$  are subterms of an underlined redex  $(\underline{\lambda x. \dots D(x) \dots})$  such that  $x \in \text{FV}(D)$ , then  $C \subset^* D$
- (iii)  $c^*$  is transitive.

(2)  $c^{**}$  is defined by:

$C \subset^{**} D \iff$  for some development  $M \longrightarrow \dots \longrightarrow M'$  and some descendants  $C', D' \subseteq M'$  of  $C, D$  we have  $C' \subset D'$ .

4.3.5. PROPOSITION. Let  $M \in \underline{\lambda\beta}$  and  $M \xrightarrow{\underline{\beta}} M'$ .

Let  $C', D' \subseteq M'$  be some descendants of  $C, D \subseteq M$ . Then  $C' \subset^* D' \Rightarrow C \subset^* D$ .

PROOF. If  $C' \subset^* D'$  in virtue of clause (i), then it is easy to see that  $C \subset^* D$  in virtue of clause (i) or (ii).

If  $C' \subseteq D'$  in virtue of (ii), then  $M' \equiv \text{---}(\underline{\lambda x. \text{---}D'(x)\text{---}})\text{---}(\text{---}C'\text{---})\text{---}$  and now there are 2 cases:

CASE 1.  $M \equiv \text{---}((\underline{\lambda x. \text{---}D(x)\text{---}})\text{---}(\text{---}C\text{---}))\text{---}$ : then  $C \subset^* D$  by clause (ii).

CASE 2.  $M \equiv \text{---}[[\underline{\lambda y. \text{---}((\underline{\lambda x. \text{---}D(x)\text{---}})\text{---}(\text{---}y\text{---}))\text{---}}][\text{---}C\text{---}]]\text{---}$

E

Then  $D \supset^* E \supset^* C$ , hence  $D \supset^* C$ .

(Since  $x \in \text{FV}(D)$  there are no other cases to consider.)

Finally, the case that  $C' \subset^* D'$  by clause (iii), is trivial to deal with.  $\square$

4.3.6. LEMMA (Hyland). Let  $M \in \underline{\lambda\beta}$ .

(i) For all  $C, D \subseteq M$  ( $D \not\ni x$ ):

$$C \subset^* D \iff C \subset^{**} D.$$

- (ii)  $c^*$  is a strict partial ordering (p.o.) on  $\text{Sub}(M)$ .  
 (iii) Likewise for  $c^{**}$ .

PROOF. (i)  $\Rightarrow$ . Suppose  $C \subset^* D$  and  $D$  is not a variable. (That  $D$  is not allowed to be a variable is because  $C \subset^* x$  is possible, but never  $C \subset^{**} x$  since an  $x$  has no descendants after a substitution for  $x$ .)

Then in fact, say,

$$D \equiv D_0 \supset_{(ii)}^* D_1 \supset_{(i)}^* D_2 \supset_{(ii)}^* \dots \supset_{(ii)}^* D_k \equiv C$$

for some chain of applications of clauses (i) or (ii). Now, drawing a figure of the term-formation tree of  $M$  and looking for a few moments at the chain  $D, D_1, \dots, C$  in it, it is intuitively entirely clear that there is a development at the end of which one has  $C' \subset D'$  for some residuals  $C', D'$  of  $C, D$ .

The formal proof, however, is rather tedious since it involves a lot of checking of simple details. The proof will be given using induction to  $k$ , the number of 'steps' in the displayed chain from  $D$  to  $C$ .

CASE 1. Let the first 'step', from  $D_0$  to  $D_1$ , be a  $\supset_{(ii)}^*$ -application. Let  $R \equiv (\underline{\lambda x} \dots D_0(x) \dots) (\dots D_1 \dots)$  be the corresponding underlined redex. Then after contraction of  $R$  the original chain  $D_0, \dots, C$  is transformed into a chain  $D'_0, \dots, C$  as follows:

$$\begin{array}{ccccccc}
 D_0 & \supset_{(ii)}^* & D_1 & \supset_{(i)}^* & D_2 & \supset_{(ii)}^* \dots \supset_{(ii)}^* & D_k \equiv C \\
 \vdots & & \vdots & & \vdots & & \vdots \\
 \underline{\lambda x} \downarrow & & \downarrow & & \downarrow & & \downarrow \\
 D'_0 & \supset_{(i)}^* & D'_1 & \supset_{(i)}^* & D'_2 & \supset_{(ii)}^* \dots \supset_{(ii)}^* & D'_k \equiv C
 \end{array}$$

$(\underline{\lambda x} \dots \downarrow \dots)$  denotes  
 the descendant  
 relation w.r.t.  
 contraction of the  
 $\underline{\lambda x}$ -redex)

where each (i)- or (ii)-step is carried over in a similar step except the first step; so in the latter chain  $D'_0, \dots, C$  there are less (ii)-steps.

CASE 2. The situation  $D_0 \supset_{(i)}^* D_1 \supset_{(ii)}^* \dots C$  where  $D_1 \neq x$ , the bound variable of the underlined redex  $R$  corresponding to the step  $D_1 \supset_{(ii)}^* D_2$ , is similar. Then also the first  $\supset_{(ii)}^*$ -step becomes a  $\supset_{(i)}^*$ -step after contraction of  $R$  and the other steps stay similar.

Otherwise we have:

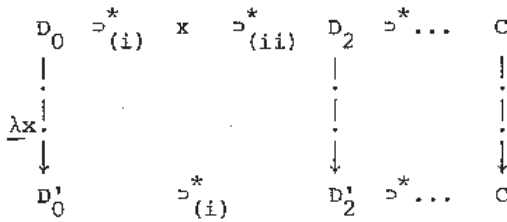

etcetera.

So, by induction to the number of  $\supset^*_{(ii)}$ -steps in  $D \supset^* \dots \supset^* C$  we are through.

(In order to prove the assertions in 'Case 1' and 'Case 2', one has to check the propositions

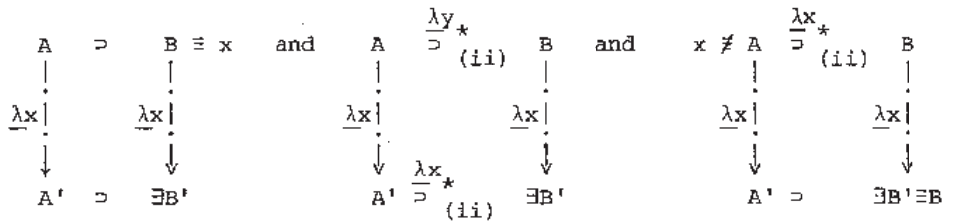

i.e. for all  $A, A', B$  as in the diagram, there exists  $B'$  as in the diagram.)

This ends the proof of (i)  $\Rightarrow$ .

(i)  $\Leftarrow$ : Suppose  $C \subset^{**} D$ , i.e. there is a development  $R: M \equiv M_0 \longrightarrow M_1 \longrightarrow \dots M_k \equiv M'$  and descendants  $C', D' \subseteq M'$  of  $C, D \subseteq M$  such that  $C' \subset D'$ .

Now use induction on the number of steps in  $\mathcal{R}$ . The basis of the induction is trivial. Further, there are  $C'', D'' \subseteq M_1$ , descendants from  $C, D \subseteq M_0$ , and having descendants  $C', D' \subseteq M'$  such that  $C' \subset D'$ . So by induction hypothesis  $C' \subset^* D'$ . Hence by Prop. 4.3.5  $C \subset^* D$ .

(ii) Immediately. Notice that:

$C \subset^* D \Rightarrow$  the head-symbol of  $C$  is to the left of the head-symbol of  $D$ .

(iii) We have only to show that  $\subset^{**}$  is transitive. So let  $C \subset^{**} E \subset^{**} D$ . Then  $E \neq x$ , hence we can apply (i) and get  $C \subset^{**} D$ .  $\square$

4.3.7. COROLLARY.  $\lambda\beta \models DP$ .

PROOF. Since  $\subset^{**}$  is a strict p.o., we have for no  $C, C \subset^{**} C$ . That is: DP.  $\square$

4.3.8. REMARK. In HYLAND [73]  $c^*$  is written as  $>$ . Lemma 4.3.6 is used there to prove FD as follows. Define for each underlined redex  $R$  in  $M \in \underline{\lambda\beta}$  the degree  $d(R)$  by

$$d(R) = \max\{d(R') \mid R' \triangleright^* R\} + 1$$

(the  $R'$  are underlined redexes in  $M$ ) and assign to  $M$  the multiset of the  $d(R)$  for all underlined redexes  $R$  in  $M$ . This multiset is argued to decrease (w.r.t. the well-ordering in Prop. 6.4.2) during a development. This argument, however, seems incomplete since there is a complication due to the fact that the p.o.  $c^*$  need not be a tree (see figure below), like  $c$  is. The complication can be avoided however by using instead of  $d(R)$ :

$$d'(R) = \max\{d'(R') \mid R' \subset^* R\} + 1.$$

EXAMPLE. The p.o. (w.r.t.  $c^*$ ) of underlined redexes  $R$  in  $M$  plus degrees  $d'(R)$ .

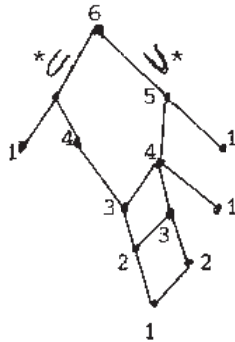

For 'fast' developments (reductions in  $\underline{\lambda\beta}_m$ , see 4.2) we have analogous definitions of  $c_m^*$  and  $c_m^{**}$ :

4.3.9. DEFINITION. Let  $M \in \underline{\lambda\beta}_m$ . Then for  $C, D \subseteq M$ :

- (i)  $C \subseteq D \Rightarrow C \subset_m^* D$
- (ii) if  $C, D$  are subterms of an underlined redex

$$\begin{array}{c} \xrightarrow{\lambda \vec{x} \vec{y}. \dots D(x_i) \dots} A_1 A_2 \dots A_i \dots A_n \\ \cup \\ C \end{array}$$

where  $\vec{x} = x_1, \dots, x_n$  (some  $n \geq 1$ ),  $\vec{y} = y_1, \dots, y_m$  (some  $m \geq 0$ ),  $i$  some number such that  $1 \leq i \leq n$  and  $x_i \in FV(D)$ , then  $C \subset_m^* D$ .

- (iii)  $C \subset_m^* E \subset_m^* D \Rightarrow C \subset_m^* D$ .

The definition of  $c_m^{**}$  carries over immediately from Def. 4.3.4.(ii). Likewise Prop. 4.3.5 and Lemma 4.3.6, as the reader may check.

Hence the following fact, needed in Ch.II:

4.3.10. COROLLARY.  $\lambda\beta_m \vdash DP.$   $\square$

## 5. ABSTRACT REDUCTION SYSTEMS

In this section we define some properties of 'abstract' reduction systems (i.e. *replacement systems* in the sense of STAPLES [75]) and state some simple facts about them, for the most part well-known. This is done only in as far we need those definitions and facts in the sequel; we are not primarily interested here in abstract reduction systems and their properties for their own sake. For the latter, see e.g. HUET [78], STAPLES [75], HINDLEY [69,74].

Part of this section (5.16,5.17,5.18) is for use in Chapter II, the remark about 'conservative extensions' (5.10,5.11) is referred to in Chapter III.

We start with some definitions and notations (a few of them occurred already above, but are repeated for the sake of completeness).

5.1. DEFINITION. (1) An *abstract reduction system* (ARS) is a structure  $\bar{A} = \langle A, \xrightarrow{\alpha} \rangle_{\alpha \in I}$  consisting of some set  $A$  and some sequence of binary relations  $\xrightarrow{\alpha}$  ( $\alpha \in I$ ), called *reduction relations*.

(2) Mostly we will be interested in ARS's  $\bar{A} = \langle A, \longrightarrow \rangle$  having only one reduction relation.

These are called *replacement systems* in STAPLES [75].

(3)  $\longrightarrow$  is the transitive reflexive closure of  $\longrightarrow$ ,

$\xrightarrow{\equiv}$  is the reflexive closure of  $\longrightarrow$ ,

$\equiv$  is the 'convertibility' relation (i.e. the equivalence relation) generated by  $\longrightarrow$ .

Likewise  $\xrightarrow{\alpha} \gg$ ,  $\xrightarrow{\alpha} \equiv$ ,  $\equiv_{\alpha}$  for  $\xrightarrow{\alpha}$ .

Identity of elements of  $A$  is denoted by  $\equiv$ .

(4) The *converse* relation of  $\xrightarrow{\alpha}$  is denoted by  $\xleftarrow{\alpha}$  or by  $\xrightarrow{\alpha^{-1}}$ .

(5)  $\xrightarrow{\alpha} \cup \xrightarrow{\beta}$  is denoted by  $\xrightarrow{\alpha\beta}$ .

5.2. DEFINITION. (1) Let  $\alpha, \beta$  be reduction relations on  $A$ . Then  $\alpha \otimes \beta$  ( $\alpha$  *commutes weakly with*  $\beta$ ) iff

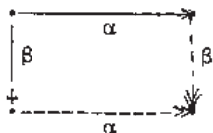

where the dotted arrows have the usual existential meaning, i.e.:

$$\forall a, b, c \in A \exists d \in A (c \xleftarrow{\beta} a \xrightarrow{\alpha} b \Rightarrow c \xrightarrow{\alpha} d \xleftarrow{\beta} b).$$

Further,  $\alpha$  commutes with  $\beta$  iff  $\xrightarrow{\alpha} \circ \xrightarrow{\beta}$ .

(2) The reduction relation  $\longrightarrow$  is called 'weakly Church-Rosser' (WCR) iff  $\longrightarrow$  is weakly self-commuting:

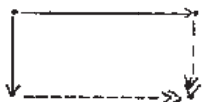

$$\text{i.e. } \forall a, b, c \exists d \in A (c \xleftarrow{\beta} a \xrightarrow{\alpha} b \Rightarrow c \xrightarrow{\alpha} d \xleftarrow{\beta} b).$$

(3)  $\longrightarrow$  is called *subcommutative* (as in STAPLES [77]), notation  $\text{WCR}^{\leq 1}$ , iff

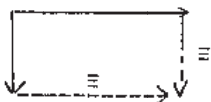

$$\text{i.e. } \forall a, b, c \exists d (c \xleftarrow{\beta} a \xrightarrow{\alpha} b \Rightarrow c \xrightarrow{\alpha} d \xleftarrow{\beta} b).$$

(4)  $\longrightarrow$  has the *Church-Rosser* property ('is CR') iff

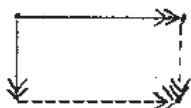

$$\text{i.e. } \forall a, b, c \exists d (c \xleftarrow{\beta} a \xrightarrow{\alpha} b \Rightarrow c \xrightarrow{\alpha} d \xleftarrow{\beta} b).$$

(5) Let  $A = \langle A, \xrightarrow{\alpha}, \xrightarrow{\beta} \rangle$ . Then  $A \models \text{PP}_{\alpha, \beta}$  (Postponement of  $\beta$ 's after  $\alpha$ 's) iff for all  $a, a' \in A$ :

$$a \xrightarrow{\alpha\beta} a' \Rightarrow \exists b \in A a \xrightarrow{\alpha} b \xrightarrow{\beta} a'.$$

**5.3. PROPOSITION.** Let  $A = \langle A, \longrightarrow \rangle$  be an ARS. Then the following are equivalent:



- (i)  $\longrightarrow$  is CR
- (ii)  $\twoheadrightarrow$  is WCR (weakly self-commuting)
- (iii)  $\twoheadrightarrow$  is self-commuting
- (iv)  $\twoheadrightarrow$  is WCR<sup>≤1</sup>
- (v)  $\overset{PP}{\twoheadrightarrow}_{\rightarrow, \leftarrow}$
- (vi)

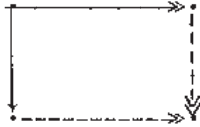

- i.e.  $\forall a, b, c \exists d (c \longleftarrow a \twoheadrightarrow b \Rightarrow c \twoheadrightarrow d \longleftarrow b)$
- (vii)  $\forall a, b \exists c (a \equiv b \Rightarrow a \twoheadrightarrow c \longleftarrow b)$   
 (= is the equivalence relation generated by  $\longrightarrow$ )

PROOF. The equivalence of (i), ..., (iv) follows at once from the definitions. The proof of the remaining equivalences is routine.  $\square$

5.4. REMARK. (vi) is called 'property C' in NEWMAN [42]. Cfr. also the 'Strip Lemma' in BARENDREGT [76]. (vii) is often used as definition of the CR-property.

In NEWMAN [42], HUET [78] a CR reduction relation is called 'confluent'.

5.5. PROPOSITION. Let  $A = \langle A, \xrightarrow{\alpha}, \xrightarrow{\beta} \rangle$ . Let  $\alpha$  commute with  $\beta^{-1}$ . Then  $A \models PP_{\alpha, \beta}$ .

PROOF. It suffices to prove that  $\xrightarrow{\beta} \twoheadrightarrow$  and  $\xrightarrow{\alpha} \twoheadrightarrow$  can be interchanged:

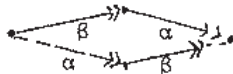

This follows at once from the hypothesis that  $\alpha$  commutes with  $\beta^{-1}$ .  $\square$

5.6. DEFINITION. Let  $A = \langle A, \longrightarrow \rangle$ .

- (1)  $a \in A$  is a normal form (w.r.t.  $\longrightarrow$ ) iff  $\neg \exists b \in A a \rightarrow b$ .  $b \in A$  has a normal form iff  $\exists a \in A a$  is nf &  $b \twoheadrightarrow a$ .
- (2)  $A \models WN$  ( $\longrightarrow$  is weakly normalizing) iff every  $a \in A$  has a nf.
- (3)  $A \models SN$  ( $\longrightarrow$  is strongly normalizing) iff every reduction in  $A$  terminates. (In HUET [78]:  $\longrightarrow$  is noetherian.)
- (4)  $A \models UN$  (unicity of normal forms) iff

$$\forall a, b \in A (a, b \text{ are nf} \ \& \ a \equiv b \Rightarrow a = b).$$

(5)  $A \models \text{NF}$  (normal form property) iff

$$\forall a, b \in A \ (a \text{ is nf} \ \& \ a=b \Rightarrow b \twoheadrightarrow a).$$

In the following lemma some sufficient conditions for the CR property are given.

5.7. LEMMA. Let  $A \models \langle A, \twoheadrightarrow \rangle$ . Then the following implications hold:

(1) (Newman)  $\text{SN} \ \& \ \text{WCR} \Rightarrow \text{CR}$ .

(2)  $\text{WN} \ \& \ \text{UN} \Rightarrow \text{CR}$ .

(3)  $\text{WCR}^{\leq 1} \Rightarrow \text{CR}$

(4) (Hindley, Rosen) Let  $\twoheadrightarrow$  be  $\xrightarrow{\alpha_1} \cup \xrightarrow{\alpha_2}$ . Suppose  $\alpha_i$  commutes with  $\alpha_j$  for all  $i, j \in \{1, 2\}$  (so in particular the  $\alpha_i$  are self-commuting, i.e. CR).

Then  $\twoheadrightarrow$  is CR.

(Analogously for  $\twoheadrightarrow = \bigcup_{i \in I} \alpha_i$ .)

PROOF.

(1) See NEWMAN [42]; or for a shorter proof, HUET [78].

(2) Let reductions  $a \twoheadrightarrow b$  and  $a \twoheadrightarrow c$  be given. By WN  $b, c$  have normal forms  $b'$  resp.  $c'$ . By UN  $b' \equiv c'$ . So

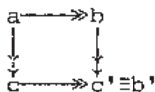

(3) Easy.

(4) Easy (see e.g. STAPLES [75]).  $\square$

5.8. REMARK. Note that  $\text{WCR} \not\equiv \text{CR}$ , as is shown by the ARS defined as in Figure 1 of 5.9. Figures 2, 3, 4 give similar counterexamples. Now the following question arises. First we define for  $n, m \geq 1$ :

$$A \models \text{WCR}_{n,m} \quad \text{iff} \quad \begin{array}{ccc} & \xrightarrow{\leq n} & \\ \downarrow \xrightarrow{\leq m} & & \downarrow \\ & \xrightarrow{\leq n} & \end{array}$$

where  $\xrightarrow{\leq n}$  denotes a reduction of at most  $n$  steps. (So  $\text{WCR}_{1,1} = \text{WCR}$ .) The above mentioned counterexamples show  $\text{WCR}_{1,1} \not\equiv \text{CR}$ . Question:  $\text{WCR}_{n,m} \not\equiv \text{CR}$

for all  $n, m \geq 1$ ? Indeed one can find for every  $n, m \geq 1$  an  $A$  such that  $A \models \text{WCR}_{n,m}$  but  $A \not\models \text{CR}$ . Figure 5 gives an  $A$  where  $\text{WCR}_{2,2}$  is satisfied but not  $\text{WCR}_{1,3}$ .

In fact, one can find all sorts of 'logically possible' counterexamples, in the following sense. Call a set  $B \subseteq \mathbb{N}_+^2$  closed iff  $(n,m) \in B \Rightarrow (m,n) \in B$  and  $(n+1,m) \in B \Rightarrow (n,m) \in B$ . (Here  $\mathbb{N}_+ = \mathbb{N} - \{0\}$ .) Define  $\text{WCR}(A) := \{(n,m) \in \mathbb{N}_+^2 \mid A \models \text{WCR}_{n,m}\}$ ; so  $\text{WCR}(A)$  measures 'how CR'  $A$  is. (Example: for  $A$  in figure 6 we have  $\text{WCR}(A)$  as in figure 7 of 5.9.) Obviously  $\text{WCR}(A)$  is closed, and:

$$\begin{aligned}
 A \models \text{CR} &\iff \\
 \text{WCR}(A) = \mathbb{N}_+^2 &\iff \\
 \forall n \in \mathbb{N}_+ (1,n) \in \text{WCR}(A) &\iff \\
 \text{WCR}(A) \text{ is infinite.} &
 \end{aligned}$$

Now let an arbitrary finite closed  $B \subseteq \mathbb{N}_+^2$  be given. Then (we claim without proof) one can construct an  $A$  such that  $\text{WCR}(A) = B$ .

5.9. EXAMPLES. (In the following figures the direction of the reduction arrows, when not indicated, is always to the right and/or downwards.)

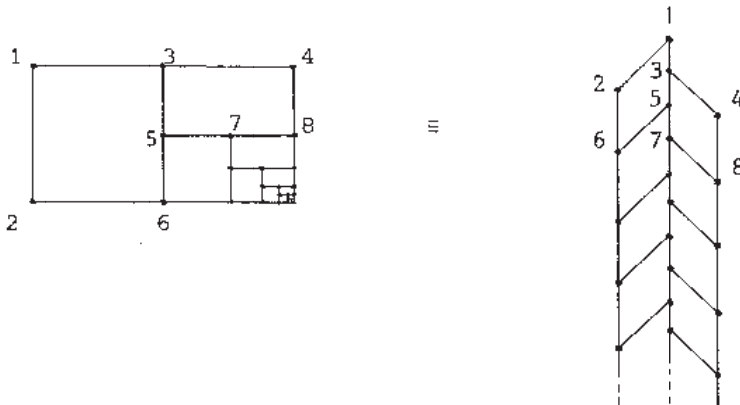

Figure 1

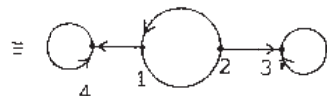
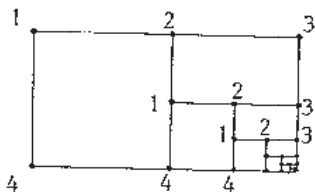

Figure 2

Figure 3

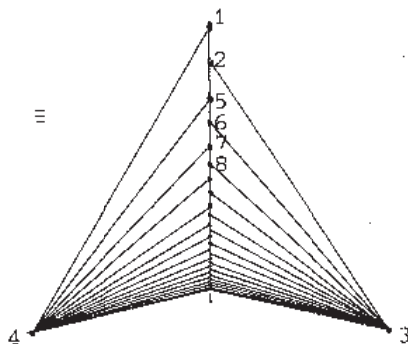
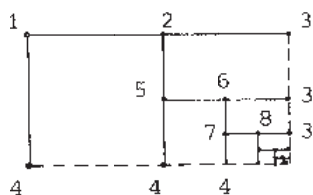
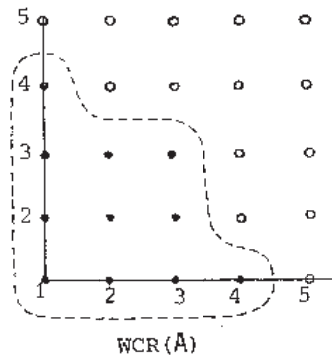
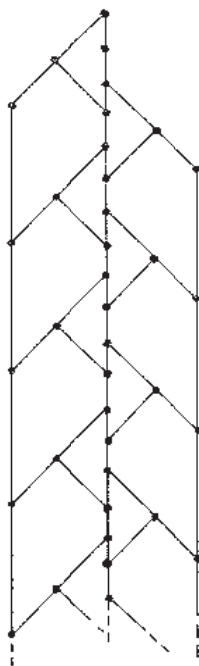
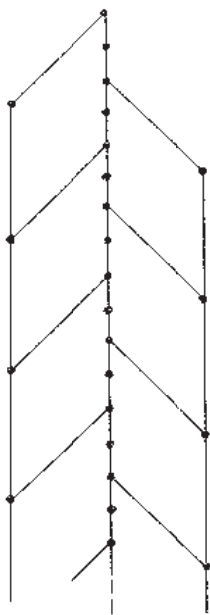

Figure 3

Figure 4



WCR(A)

Figure 5

Figure 6

Figure 7

5.10. DEFINITION.

(1) Let  $\bar{A} = \langle A, \xrightarrow{A} \rangle$ .  $\bar{A}$  is consistent iff  $\neq_A \neq A \times A$ , i.e. not every pair of elements is convertible.

(2) Let  $\bar{A} = \langle A, \xrightarrow{A} \rangle$  and  $\bar{B} = \langle B, \xrightarrow{B} \rangle$ .

Then  $\bar{A} \subseteq \bar{B}$  ( $\bar{B}$  is an extension of  $\bar{A}$ , or:  $\bar{A}$  is a substructure of  $\bar{B}$ ) iff

(i)  $A \subseteq B$

(ii)  $\xrightarrow{A} =$  restriction of  $\xrightarrow{B}$  to  $A$ , i.e.

$$\forall a, a' \in A (a \xrightarrow{B} a' \iff a \xrightarrow{A} a').$$

(iii)  $A$  is closed under  $\xrightarrow{B}$ , i.e.

$$\forall a \in A (a \xrightarrow{B} b \implies b \in A).$$

(3) Let  $\bar{A} \subseteq \bar{B}$ .  $\bar{B}$  is a conservative extension of  $\bar{A}$  iff

$$\forall a, a' \in A (a =_B a' \iff a =_A a').$$

REMARK. Note that a conservative extension  $\bar{B}$  of a consistent  $\bar{A}$  is again consistent.

The next theorem gives some important consequences of the CR property.

5.11. THEOREM.

(1) Let  $\bar{A} = \langle A, \xrightarrow{A} \rangle$  and let there be two distinct normal forms in  $A$ . Then:  
 $A \models \text{CR} \implies \bar{A}$  is consistent.

(2)  $\text{CR} \implies \text{UN}$

(3)  $\text{CR} \implies \text{NF}$

(4) Let  $\bar{A} \subseteq \bar{B}$ . Then:  $\bar{B} \models \text{CR} \implies \bar{B}$  is a conservative extension of  $\bar{A}$ .

The proofs are very elementary and will be omitted.

We will now make a remark about cofinality (see also §12). First some definitions.

5.12. DEFINITION. Let  $\bar{A} = \langle A, \xrightarrow{A} \rangle$  be an ARS and  $a \in A$ . Let  $A_a = \{b \mid a \twoheadrightarrow b\}$  and  $\xrightarrow{A}_a$  be the restriction of  $\xrightarrow{A}$  to  $A_a$ .

Then the reduction graph of  $a$ ,  $G(a)$ , is the ARS  $\langle A_a, \xrightarrow{A}_a \rangle$ .

(In STAPLES [75]  $G(a)$  is called the 'local system below  $a$ '.)

5.13. DEFINITION. Let  $A = \langle A, \twoheadrightarrow \rangle$  be an ARS.

- (i) Let  $X, Y \subseteq A$ . Then  $Y$  is cofinal in  $X$  iff  $Y \subseteq X$  and  $\forall x \in X \exists y \in Y x \twoheadrightarrow y$ .  
 (ii)  $A \models \text{CP}$  (' $A$  has the cofinality property') iff in every reduction graph  $G(a)$  ( $a \in A$ ) there is a cofinal reduction sequence  $\mathcal{R}: a \equiv a_0 \twoheadrightarrow a_1 \twoheadrightarrow \dots$  (finite or infinite).

I.e.:

$$\forall b \in G(a) \exists a_n \in \mathcal{R} \quad b \twoheadrightarrow a_n.$$

5.14. THEOREM. Let  $A = \langle A, \twoheadrightarrow \rangle$  be a countable ARS. Then:

$$A \models \text{CP} \iff A \models \text{CR}.$$

PROOF. ( $\Rightarrow$ ) Suppose  $a \twoheadrightarrow b$  and  $a \twoheadrightarrow c$ . By CP there is a cofinal

$\mathcal{R}: a \equiv a_0 \twoheadrightarrow a_1 \twoheadrightarrow \dots$  in  $G(a)$ . Hence  $b \twoheadrightarrow a_n$  and  $c \twoheadrightarrow a_m$  for some  $n, m$ . Say  $n \leq m$ . Then  $a_m$  is a common reduct of  $b, c$ . Hence CR holds.

( $\Leftarrow$ ) Let  $a_0 \in A$  and consider  $G(a_0)$ . By hypothesis,  $G(a_0)$  is countable; say  $G(a_0) = \{a_n \mid n \in \mathbb{N}\}$ . (The case that  $G(a_0)$  is finite is easy.) Now define a sequence  $\{b_n \mid n \in \mathbb{N}\} \subseteq G(a_0)$ , by induction on  $n$ :

$$\begin{aligned} b_0 &\equiv a_0 \\ b_{n+1} &\equiv \text{the first common reduct of } b_n \text{ and } a_{n+1} \text{ in the sequence} \\ &\quad \{a_0, a_1, \dots\}. \end{aligned}$$

Then  $\{b_n \mid n \in \mathbb{N}\}$  is cofinal in  $G(a_0)$ , and yields a cofinal reduction sequence  $b_0 \twoheadrightarrow b_1 \twoheadrightarrow \dots$  (after interpolation of reduction steps between  $b_k$  and  $b_{k+1}$ ,  $k \geq 0$ ).  $\square$

5.15 REMARK. (i) The restriction to countable ARS's is essential for the implication  $\text{CR} \Rightarrow \text{CP}$ . A counterexample for uncountable ARS's is obtained by taking  $A = \langle A, \twoheadrightarrow \rangle =: \langle \alpha, \twoheadrightarrow \rangle$  where  $\alpha$  is an ordinal in which the ordinal  $\omega$  is not cofinal.

(ii) Let  $A = \langle A, \twoheadrightarrow \rangle$  be an ARS and define  $K \subseteq A$  to be a *reduction chain* iff

$$\forall a, b \in K \quad (a \twoheadrightarrow b \vee b \twoheadrightarrow a).$$

Furthermore, let us call CP' the property obtained by replacing in Definition 5.13 of CP 'reduction sequence' by 'reduction chain'.

Now it is an easy exercise to prove that for countable  $A$ ,  $CP \Leftrightarrow CP'$ .

Also now, however, the restriction to countable ARS's is essential for the implication  $CR \Rightarrow CP'$ . For, consider the following uncountable counter-example: let  $A'$  be an uncountable set and let  $A = \{X \subseteq A' \mid X \text{ finite}\}$ . Then  $A = \langle A, \longrightarrow \rangle = \langle A, \subseteq \rangle$  is an ARS such that  $A \models CR$ . But: for every reduction chain  $K \subseteq A$ , the union  $\bigcup_{X \in K} X$  is countable. Hence if  $a \in A' - \bigcup K$ , then for no  $X \in K$  one has  $\{a\} \subseteq X$  (i.e.  $\{a\} \longrightarrow X$ ). Therefore  $K$  is not cofinal in  $G(\emptyset) = A$ .

Although the next two items are for use in Chapter II, we include them here since they also apply to abstract reduction systems.

5.16. DEFINITION. Let  $A = \langle A, \longrightarrow \rangle$ .

- (1)  $A$  is *inductive* (as in HUET [78]) iff for every reduction  $a_0 \longrightarrow a_1 \longrightarrow a_2 \longrightarrow \dots$  (finite or infinite) there is some  $a \in A$  such that  $a_n \longrightarrow a$  for all  $n$ . Notation:  $A \models \text{Ind}$ .
- (2)  $A$  is *increasing* iff there is a map  $|\cdot|: A \rightarrow \mathbb{N}$  such that for all  $a, b \in A$ :

$$a \longrightarrow b \Rightarrow |a| < |b|.$$

Notation:  $A \models \text{Inc}$ .

- (3)  $A$  is *well-founded* iff there are no 'infinite descending  $\longrightarrow$ -chains'  $\dots \longrightarrow a_3 \longrightarrow a_2 \longrightarrow a_1 \longrightarrow a_0$ . (Equivalently, iff  $\xrightarrow{-1} = \longleftarrow$  is SN.) Notation:  $A \models \text{WF}$ .
- (4)  $A$  is *finitely branching* iff for all  $a \in A$  the set of immediate reducts of  $a$ ,  $\{b \in A \mid a \longrightarrow b\}$ , is finite. Notation:  $A \models \text{FB}$ . (In HUET [78],  $\text{FB} =$  'locally finite'.) Further, we write  $A \models \text{FB}^{-1}$  iff  $\xrightarrow{-1}$  is  $\text{FB}$ .

5.17. LEMMA.

- (1)  $\text{Ind} \ \& \ \text{Inc} \Rightarrow \text{SN}$  (Nederpelt)
- (2)  $\text{Inc} \Rightarrow \text{WF}$
- (3)  $\text{WN} \ \& \ \text{UN} \Rightarrow \text{Ind}$
- (4)  $\text{WF} \ \& \ \text{FB}^{-1} \Rightarrow \text{Inc}$ .

PROOF. (1) Suppose  $a_0 \longrightarrow a_1 \longrightarrow a_2 \longrightarrow \dots$  is an infinite reduction. By  $\text{Ind}$  there is an  $a$  such that  $a_n \longrightarrow a$  for all  $n$ . By  $\text{Inc}$  there is a norm  $|\cdot|$  such that  $|a_0| < |a_1| < |a_2| < \dots$ . But also  $|a_n| < |a|$  for all  $n$ . Contradiction.

(2) Trivial.

(3) A finite reduction trivially has a 'bound', namely the last element. So consider an infinite reduction  $a_0 \rightarrow a_1 \rightarrow a_2 \rightarrow \dots$ . By WN there are normal forms  $a'_n$  of  $a_n$  for all  $n$ . By UN all the  $a'_n$  are identical. Hence

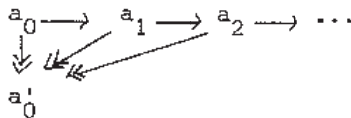

(4) Let  $A = \langle A, \rightarrow \rangle$  satisfy WF and  $FB^{-1}$ . Let  $a \in A$  and consider  $X_a = \{b \mid b \twoheadrightarrow a\}$ .

By Königs Lemma, WF and  $FB^{-1}$  imply that  $X_a$  is finite. Now define for all  $a \in A$ :  $|a| = \text{card. } X_a$ . By our previous remark,  $|a| \in \mathbb{N}$ . Moreover, if  $a \rightarrow a'$  then  $|a| < |a'|$  (for,  $a' \in X_a$  is impossible since then a reduction cycle  $a' \rightarrow a \rightarrow a'$  would arise, contradicting WF). Hence  $A \models \text{Inc}$ .  $\square$

REMARKS. Ad (1): in a less explicit form this proposition occurs in NEDERPELT [73]. In Chapter II we will extensively deal with the method introduced by NEDERPELT [73] to reduce the property SN to WN, for some systems.

Ad(3), (4): in Chapter II we will prove that for certain 'Combinatory Reduction Systems' as defined there, one has  $\text{Inc} = \text{WF}$  and  $FB^{-1} = \text{NE}$ , where NE is the property 'non-erasing' (like e.g. the  $\lambda$ I-calculus).

Finally, we will show that the property Inc entails (in the presence of WCR) the equivalence of SN and WN, a topic which will interest us especially in Chapter II. First we will prove a more general fact.

5.18. THEOREM. Let  $G(a)$  be as in Def. 5.12 and suppose:

- (1)  $G(a) \models \text{WCR}$ , and
- (2)  $a$  has a normal form  $b$  such that the length of reductions  $a \twoheadrightarrow b$  is bounded (i.e.  $\exists n \in \mathbb{N} \forall \mathcal{R}: a \twoheadrightarrow b \mid |\mathcal{R}| \leq n$ , where  $|\mathcal{R}|$  is the number of steps in  $\mathcal{R}$ ).

Then:  $G(a) \models \text{UN} \ \& \ \text{CR} \ \& \ \text{SN}$ .

PROOF.  $\text{SN} \ \& \ \text{WCR} \Rightarrow \text{CR}$  and  $\text{CR} \Rightarrow \text{UN}$ , so only to prove:  $G(a) \models \text{SN}$ .

Suppose not so. Then there is an infinite reduction

$\mathcal{R}: a \equiv a_0 \rightarrow a_1 \rightarrow a_2 \rightarrow \dots$ . Let  $X = \{c \in G(a) \mid c \twoheadrightarrow b\}$ . Then, clearly, by hypothesis (2),  $\mathcal{R}$  must leave  $X$  eventually, i.e.



$\exists k \in \mathbb{N} \forall j \geq k a_j \in X. \quad (*)$ .

Now define for  $c \in X$  the natural number

$$|c| = \max.\{|R| \mid R: c \twoheadrightarrow b\}.$$

By hypothesis (2),  $|c|$  is indeed defined. Note that for all  $c, c' \in X$ :

$$c \longrightarrow c' \Rightarrow |c| > |c'|.$$

Now we will prove by (course-of-values) induction on  $|c|$  that  $X$  is closed under reduction, i.e.:

$$c \in X \ \& \ c \longrightarrow c' \Rightarrow c' \in X. \quad (**)$$

Then we have a contradiction with (\*) and we are done.

BASIS. Suppose  $|c| = 0$ . Then  $c$  is in fact the normal form  $b$  and (\*\*) is vacuously true.

INDUCTION STEP. Induction hypothesis: suppose (\*\*) is proved for all  $c \in X$  such that  $|c| \leq n$ .

Now consider  $c_0 \in X$  such that  $|c_0| = n+1$ . (See figure below.) Let  $c \in X$  be such that  $c_0 \longrightarrow c$ ; then  $|c| \leq n$ . Suppose (for a proof by contradiction) that  $c_0 \longrightarrow d$  for some  $d \notin X$ . By WCR,  $c$  and  $d$  have a common reduct  $e$ . Since  $d \notin X$ , also  $e \notin X$ . Hence there are  $c', e'$  such that  $c \twoheadrightarrow c' \twoheadrightarrow e' \twoheadrightarrow e$  and  $c' \in X$  but  $e' \notin X$ . Now  $|c'| \leq |c| < |c_0|$ , so the induction hypothesis applies to  $c'$  and we have a contradiction. Hence (\*\*) is proved for  $c_0$ .  $\square$

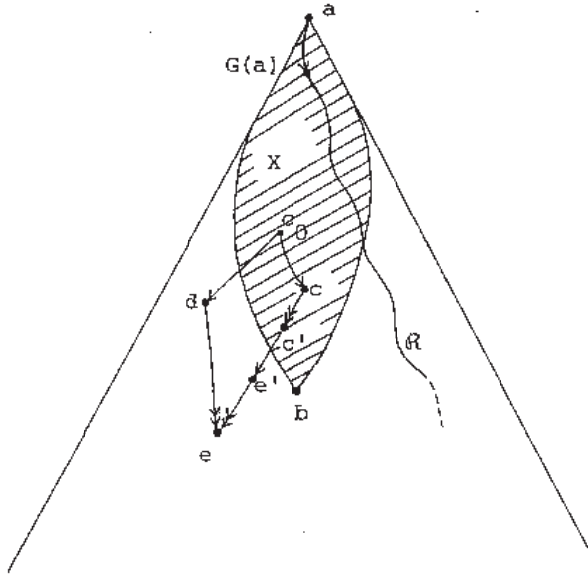

5.19. COROLLARY.

- (i)  $WCR \ \& \ WN \ \& \ Inc \Rightarrow UN \ \& \ CR \ \& \ SN$   
(ii)  $WCR \ \& \ Inc \Rightarrow (WN \Leftrightarrow SN)$ .

PROOF.

- (i) Hypothesis (2) of theorem 5.18 is ensured by Inc.  
(ii) Trivial from (i).  $\square$

5.20. The figure below gives a survey of several of the facts treated in this section.

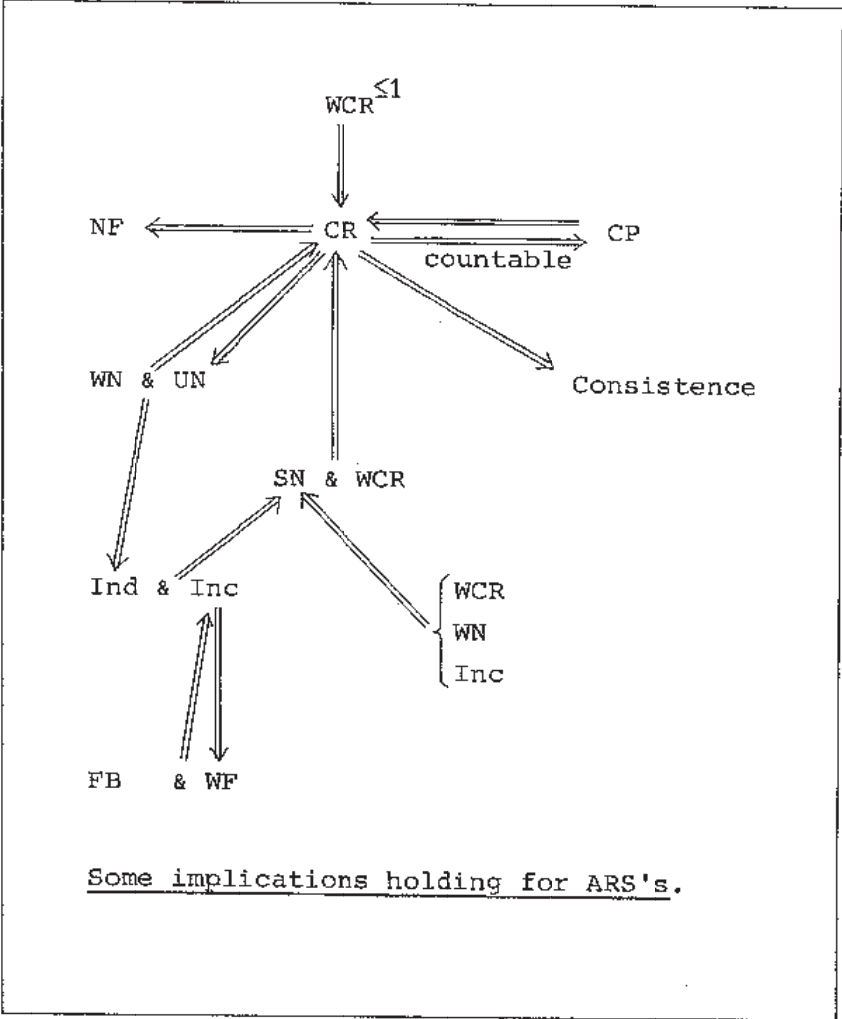

## 6. THE CHURCH-ROSSER THEOREM

After the digressions in the previous section about Abstract Reduction Systems we will now return to the main theme of this Chapter,  $\lambda$ -calculus plus labels and definable extensions  $\lambda P$  of  $\lambda$ -calculus. Note that these 'concrete' reduction systems are also ARS's; so the definitions and propositions in the previous section apply to them. Often we will be able to prove refined results for these systems, by considering not only the *binary* reduction relations  $M \longrightarrow N$ , but the *ternary* relation  $M \xrightarrow{R} N$  obtained by specifying (the occurrence of) the contracted redex in  $M$ .

We will prove in this section that  $\lambda^L$ ,  $\lambda P \models \text{CR}$ , i.e. the Church-Rosser theorem holds for Lévy's  $\lambda$ -calculus, hence for all other labeled (typed, underlined)  $\lambda$ -calculi we considered in §3, and for definable extensions of  $\lambda$ , hence for CL.

Let us remind Def. 5.2.(4) of CR: if  $\mathcal{R}_1 = A \longrightarrow \dots \longrightarrow B$  and  $\mathcal{R}_2 = A \longrightarrow \dots \longrightarrow C$  are two 'divergent' reductions, one can find 'convergent' reductions  $\mathcal{R}_3$  and  $\mathcal{R}_4$ :

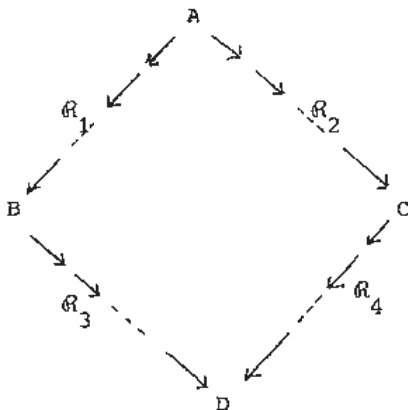

An alternative formulation (easily seen to be equivalent; see also Prop.5.3) is:

$$\forall B, C \exists D (B = C \Rightarrow B \twoheadrightarrow D \ \& \ C \twoheadrightarrow D)$$

e.g.

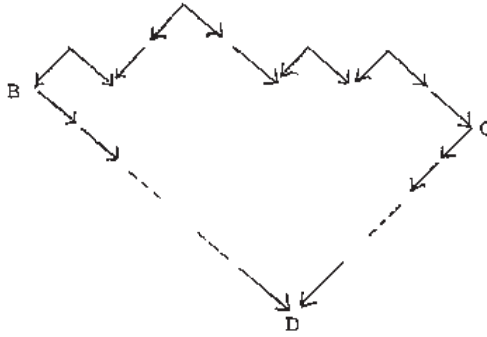

Some important consequences of the CR theorem are mentioned in Theorem 5.11.

We will prove CR using FD (Theorem 4.1.11). In fact a strengthened version  $CR^+$  is proved; namely, there is a *canonical* procedure of finding the common reduct  $D$  of  $B$  and  $C$ . Moreover we will obtain as corollaries the well-known Lemma of Parallel Moves, and the commutativity of  $\beta$ - and  $\rho_i$ -reductions (see Def.5.2.(1)).

An almost similar version of  $CR^+$  for  $\lambda^L$  was first proved by LÉVY [78], not via FD however. Here we look in a slightly more detailed way to what happens in a 'reduction diagram', which will help us in Chapter IV to deal with  $\beta\eta$ -reductions.

The method below of constructing a reduction diagram by 'tiling' was independently considered by Hindley (in an unpublished note).

### 6.1. CONSTRUCTION OF REDUCTION DIAGRAMS

Let two coinital finite reduction sequences  $R_1 = M_0 \longrightarrow \dots \longrightarrow M_n$  and  $R_2 = M_0 \longrightarrow M'_1 \longrightarrow \dots \longrightarrow M'_m$  be given. We want to construct a common reduct of  $M_n$  and  $M'_m$  by filling up a diagram  $D$  as indicated in the figure, viz. by successively adjoining 'elementary diagrams'; these are the diagrams which one obtains by checking that  $\lambda P \models WCR$  (Def.5.2.(2)).

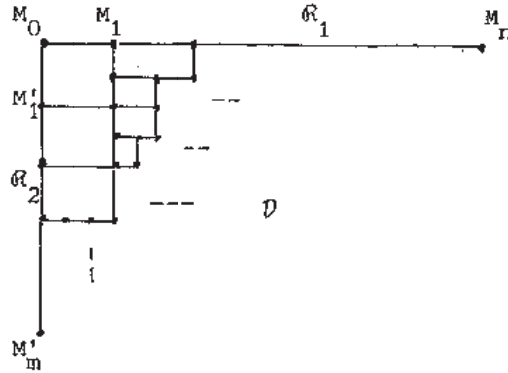

The order in which the elementary diagrams are adjoined, is unimportant. It is fairly evident what is meant by 'elementary diagrams'; however since we will use 'empty' steps, we will now list them.

6.1.1. For the  $\lambda$ -calculus the elementary reduction diagrams are of the following types.

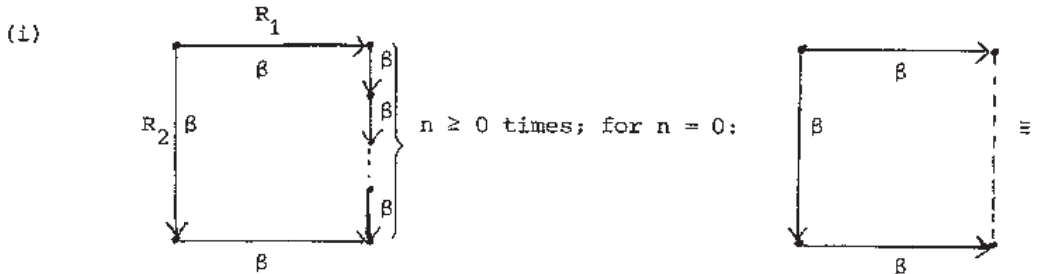

Here  $R_2 \subseteq \text{Arg}(R_1)$ , the argument of  $R_1$ , and  $\text{mult}(R_1) = n$  where  $\text{mult}((\lambda x.A)B)$  is the multiplicity of  $x$  in  $A$ .

In case  $n = 0$  and 'empty' or 'trivial' step is introduced.

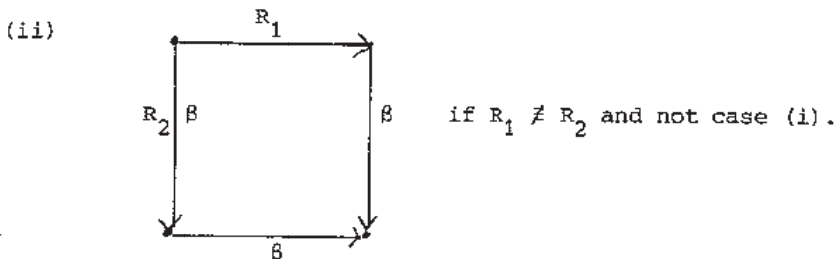

(iii)

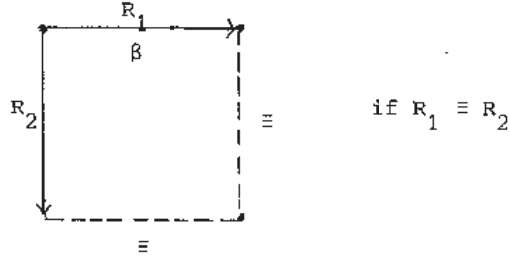

(iv)

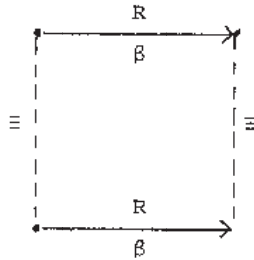

(v)

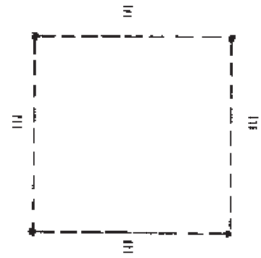

Further, we have all the elementary diagrams obtained from these by reflection in the main diagonal.

6.1.2. For definable extensions  $\lambda P$  we have moreover the following elementary diagrams:

(i)

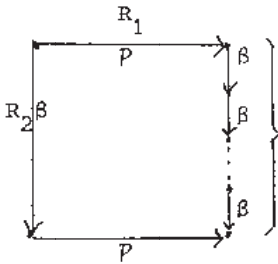

$n \geq 0$  times, in case  $R_2$  is a subterm of one of the arguments of  $R_1$ .  
Likewise with  $\beta$  and  $P$  interchanged, if  $R_2 \subseteq \text{Arg}(R_1)$ .

(ii)

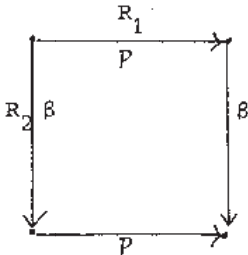

if not case (i)  
Likewise with  $\beta$ ,  $P$  interchanged.

(iii)

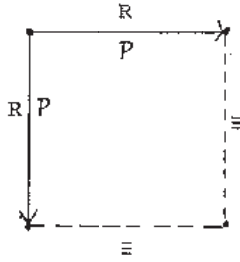

(iv)

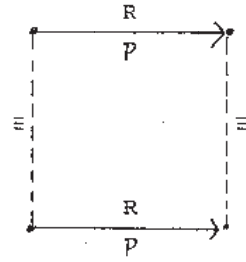

Further, all the diagrams obtained from these by reflection in the main diagonal.

The  $\equiv$  steps, at which nothing happens, are called trivial or empty ( $\emptyset$ ), and serve to keep the diagram  $\mathcal{D}$  in a rectangular shape. This enables us to have the intuition of reduction steps in a reduction diagram  $\mathcal{D}$  as objects 'moving' or 'propagating' in two directions  $\downarrow$  and  $\rightarrow$ , may be 'splitting' on the way or becoming absorbed (= changing in a  $\beta$ -step.) This intuition will prove to be especially rewarding in the  $\beta\eta$ -case, which is dealt with in Ch.IV.

Note that in each case the redexes contracted in the side BD are

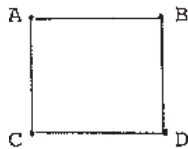

residuals of the one contracted in AC, likewise for CD and AB.

### 6.1.3. ELEMENTARY REDUCTION DIAGRAMS WITH LABELS

Let an elementary diagram (e.d.)  $\mathcal{D}$  as above be given, say

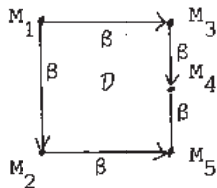

where  $M_i$  ( $i = 1, \dots, 5$ ) are unlabeled  $\lambda$ -terms.

Now let  $I_1$  be some Lévy-labeling for  $M_1$ ; result: a  $\lambda^L$ -term  $M_1^{I_1}$ . Then one has to check that  $\mathcal{D}$  extends to a labeled e.d.  $\mathcal{D}^{I_1}$ :



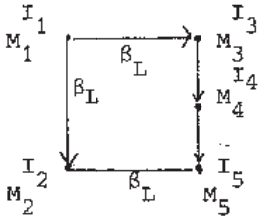

That is,  $M_1 \rightarrow M_2 \rightarrow M_5$  extends to

$$M_1^L \rightarrow M_2^{I_2} \rightarrow M_5^{I_5},$$

and  $M_1 \rightarrow M_3 \rightarrow M_4 \rightarrow M_5$  extends to

$$M_1^{I_1} \rightarrow M_3^{I_3} \rightarrow M_4^{I_4} \rightarrow M_5^{I_5},$$

and now

we must have  $I_5 = I_5'$ . This is a tedious but routine exercise which will be left to the reader.

Since the extendability of e.d.'s  $\mathcal{D}$  to labeled e.d.'s  $\mathcal{D}^I$  holds for  $\lambda^L$ , it holds also for all of the 'homomorphic images' of  $\lambda^L$ , that is for all the labeled/typed/underlined  $\lambda$ -calculi we have encountered thus far - except underlined  $\lambda^P$ -calculi (definable extensions of  $\lambda$ -calculus). For the latter a separate routine exercise yields the same result.

Since developments are a special case of underlined reduction in  $\lambda$ -calculus or  $\lambda^P$ -calculus, we note in particular that for developments we have e.d.'s.

6.1.4. DEFINITION. Elementary diagrams having two or more 'empty' steps, are called *trivial*.

## 6.2. NOTATION.

- (i) In the remainder of this chapter ' $\Sigma$ ' will denote a definable extension  $\lambda^P$  of  $\lambda$ , or a substructure of  $\lambda^P$  (w.r.t.  $\subseteq$  as defined in 5.10). So  $\Sigma$  refers for instance to  $\lambda$ ,  $\lambda I$ ,  $\lambda^P$ ,  $\lambda I^P$  (as defined in 7.1.) and CL.
- (ii)  $\underline{\Sigma}$  denotes the underlined version of  $\Sigma$ , as defined in 3.5.

## 6.3. PROPOSITION. $\underline{\Sigma} \models CR$ .

PROOF. By Theorem 4.1.11 we have  $\underline{\Sigma} \models SN$ . By 6.1.3 we have  $\underline{\Sigma} \models WCR$ . Hence by Newman's Lemma 5.7.(1),  $\underline{\Sigma} \models CR$ .  $\square$

In the next lemma the preceding proposition will be considerably strengthened. For that purpose we need transfinite induction up to the ordinal number  $\omega^\omega$ . Therefore:

## 6.4. INTERMEZZO. Transfinite induction up to $\omega^\alpha$ .

6.4.1. DEFINITION. (i) Let  $\alpha$  be some ordinal, and let  $T$  be the set of all  $n$ -tuples  $\langle \beta_1, \dots, \beta_n \rangle$  ( $n \in \mathbb{N}$ ) of ordinals less than  $\alpha$ . Let  $\cong$  be the equivalence relation on  $T$  defined by:

$$(i) \quad \langle \alpha_1, \alpha_2 \rangle \cong \langle \alpha_2, \alpha_1 \rangle$$

(ii)  $t \cong t' \Rightarrow t_1 * t * t_2 \cong t_1 * t' * t_2$  for all  $t_1, t_2 \in T$ . Here  $*$  denotes concatenation of tuples.

$$(iii) \quad t_1 \cong t_2 \ \& \ t_2 \cong t_3 \Rightarrow t_1 \cong t_3.$$

Further, let  $\mathbb{T}$  be the set of equivalence classes of  $T$  under  $\cong$ . So elements of  $\mathbb{T}$  can be thought of as tuples  $\langle \beta_1, \dots, \beta_n \rangle$  where the order of the  $\beta_i$

( $i = 1, \dots, n$ ) is irrelevant. We call the elements of  $\mathbb{T}$  also 'multisets'.

(ii) Now consider the following 'reduction relation'  $\longrightarrow$  on  $\mathbb{T}$ : in

$\langle \beta_1, \dots, \beta_i, \dots, \beta_n \rangle$  an arbitrary  $\beta_i$  ( $i = 1, \dots, n$ ) may be replaced by an arbitrarily large finite number of elements  $\gamma_{j_1}, \dots, \gamma_{j_N}$  each less than  $\beta_i$ .

So

$$\langle \beta_1, \dots, \beta_i, \dots, \beta_n \rangle \longrightarrow \langle \beta_1, \dots, \gamma_{j_1}, \dots, \gamma_{j_N}, \dots, \beta_n \rangle.$$

6.4.2. PROPOSITION. The reduction relation  $\longrightarrow$  on  $\mathbb{T}$  is strongly normalizing. In fact  $\longrightarrow$  is a well-ordering of  $\mathbb{T}$  of order type  $\omega^\alpha$ .

PROOF. Group the elements of a given tuple together as follows:

$$\underbrace{\langle \gamma_1, \gamma_1, \dots, \gamma_1 \rangle}_{n_1 \text{ times}} \quad \underbrace{\langle \gamma_2, \dots, \gamma_2 \rangle}_{n_2 \text{ times}} \quad \dots \quad \underbrace{\langle \gamma_k, \dots, \gamma_k \rangle}_{n_k \text{ times}}$$

such that  $\gamma_1 > \gamma_2 > \dots > \gamma_k$ . Assign to such a tuple the ordinal  $\omega^{\gamma_1 \cdot n_1} + \dots + \omega^{\gamma_k \cdot n_k}$  (a 'Cantor normal form'). The proposition now follows by elementary ordinal arithmetic.  $\square$

6.5. MAIN LEMMA.  $\Sigma \models CR^+$ , i.e. each construction of a  $\underline{\Sigma}$ -reduction diagram (as in 6.1) terminates.

PROOF. Consider  $M \in \text{Ter}(\underline{\Sigma})$  and  $\underline{\Sigma}$ -reductions  $\mathcal{R}_1, \mathcal{R}_2$  as in figure 6.5.1. Let the reduction diagram  $\mathcal{D}(\mathcal{R}_1, \mathcal{R}_2)$  be constructed up to the displayed stage, by the successive addition of elementary diagrams. Compared to Proposition 6.3, there is now the additional problem of the trivial steps in the e.d.'s; a priori it would be possible that they would make  $\mathcal{D}(\mathcal{R}_1, \mathcal{R}_2)$  "explode", i.e.

that the construction does not terminate but results in an Escher-like figure, with ever decreasing tiles, as in figures 6.5.2 and 6.5.3.

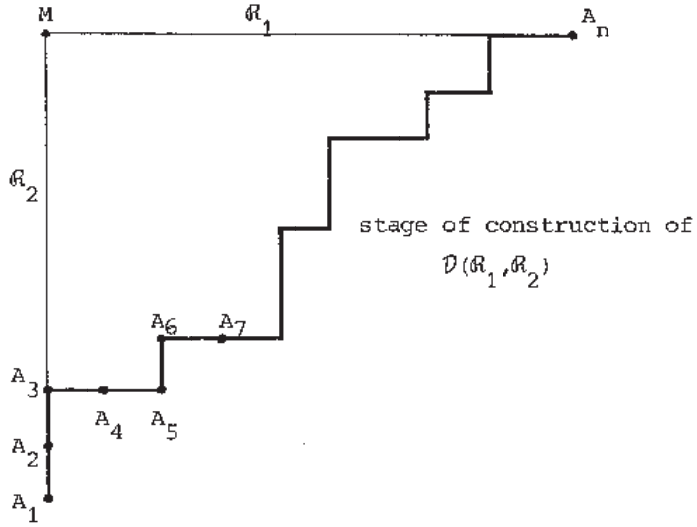

Figure 6.5.1.

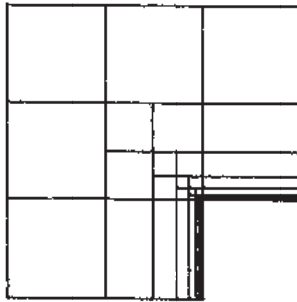

Figure 6.5.2



Figure 6.5.3

(In the last two figures care has been taken of the constraint that an e.d. can split at one side at most; so e.g.



is impossible. Figure 6.5.3 is the result of starting with the part bounded by ABCDEF, reinserting an isomorphic copy of this part in the corner CDE, and repeating this procedure ad infinitum whenever such a corner is formed.)

Give  $M$  a good weight assignment (see Definition 4.1.6). Extend  $\mathcal{R}_1, \mathcal{R}_2$  and all the reductions in  $\mathcal{D}(\mathcal{R}_1, \mathcal{R}_2)$  as far as completed, to reductions with weight assignments. By Lemma 4.1.10 the weight assignments stay good for all the terms in these reductions.

Now assign to each construction stage of  $\mathcal{D}(\mathcal{R}_1, \mathcal{R}_2)$  the multiset of natural numbers  $\langle |A_1|, |A_2|, \dots, |A_n| \rangle$  where the  $A_i$  are as in figure 6.5.1 and  $|A_i|$  is the weight of  $A_i$  ( $i = 1, \dots, n$ ). (In fact we should write  $|A_i^{I_i}|$  where  $I_i$  is the weight assignment of  $A_i$ .)

Next consider what happens to this multiset after adding an e.d. If the e.d. is trivial, the multiset remains the same. Otherwise, suppose that we add, say:

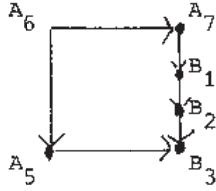

Now all the steps are proper reduction steps, so  $|A_6| > |B_i|$ ,  $i = 1, 2, 3$  by Lemma 4.1.10(ii). Hence the multiset corresponding to this stage of the construction,  $\langle |A_1|, \dots, |A_5|, |B_3|, |B_2|, |B_1|, |A_7|, \dots, |A_n| \rangle$  is less than the previous one w.r.t. the well-ordering in Proposition 6.4.2.

Therefore after some stage in the construction, no nontrivial e.d.'s can be added. Further it is clear that addition of trivial e.d.'s (which have no 'splitting' effect) must terminate too.

Finally, each diagram construction ends in the same result. This is evident by Lemma 5.7.(3), considering as objects: *stages of construction*, and as reduction: *addition of an e.d.*  $\square$

In fact, we can obtain more information out of the proof of Lemma 6.5. In order to state a refinement of this Main Lemma, we need the following definition.

#### 6.6. DEFINITION. (Complete developments)

Let  $M \in \text{Ter}(\Sigma)$  and let  $\mathcal{R}$  be the set of underlined redexes in  $M$ . Let  $\mathcal{R} = M \longrightarrow M' \longrightarrow \dots \longrightarrow N$  be a maximal  $\Sigma$ -reduction; i.e.  $N$  is a  $\Sigma$ -normal form, hence  $N$  contains no underlining.

Now let  $\mathcal{R}^*$  be the  $\Sigma$ -reduction obtained from  $\mathcal{R}$  by erasing the underlining symbols. Then  $\mathcal{R}^*$  is called a *complete ( $\Sigma$ -)development w.r.t. the set of redexes  $\mathcal{R}$* .

6.7. CONVENTION. Let  $M$ ,  $\mathcal{R}$  be as in Definition 6.6 and  $M^*$  be  $M$  without underlining. Henceforth we will identify:

- (maximal)  $\Sigma$ -reductions of  $M$ , and
- (complete)  $\Sigma$ -developments of  $M^*$  w.r.t.  $\mathcal{R}$ .

#### 6.8. REFINED MAIN LEMMA. (I) First formulation.

Let  $M \in \text{Ter}(\Sigma)$ . Let  $\mathcal{R}_i$  ( $i = 0, 1$ ) be two sets of redexes in  $M$ , and let  $\mathcal{R}_i^*$  be two complete developments w.r.t.  $\mathcal{R}_i$  ( $i = 0, 1$ ).

Then the construction of the  $\Sigma$ -reduction diagram  $\mathcal{D}(\mathcal{R}_0, \mathcal{R}_1)$  terminates (see following figure) and the right resp. lower side  $M_1 \twoheadrightarrow M_2$  is in fact a complete development of  $\mathcal{R}_1^!$ , the set of residuals of the redexes in  $\mathcal{R}_1$  ( $i = 0, 1$ ).

(II) Second formulation.

Let  $\Sigma_{01}$  be  $\Sigma$  where the head symbol of a redex may be labeled with 0, 1 or 01 and where only reduction of labeled redexes is allowed. (So  $\Sigma_{01}$  is like  $\Sigma$ , but now using underlining symbols of two 'colors'.)

Let  $M \in \text{Ter}(\Sigma_{01})$  and let  $\mathcal{R}_0$  be a  $\Sigma_{01}$ -reduction of  $M$  in which only 0- or 01-redexes are contracted; likewise in  $\mathcal{R}_1$  only 1- or 01-redexes are contracted. (See figure.) Moreover, in  $M_0$  no label 0, 01 is present, and  $M_1$  contains no label 1, 01. Then

- (i) the construction of the  $\Sigma_{01}$ -reduction diagram  $\mathcal{D}(\mathcal{R}_0, \mathcal{R}_1)$  terminates;
- (ii) in the right side  $M_0 \twoheadrightarrow M_2$  only 1-redexes are contracted and in the lower side only 0-redexes;
- (iii) moreover in  $M_2$  no labels are present.

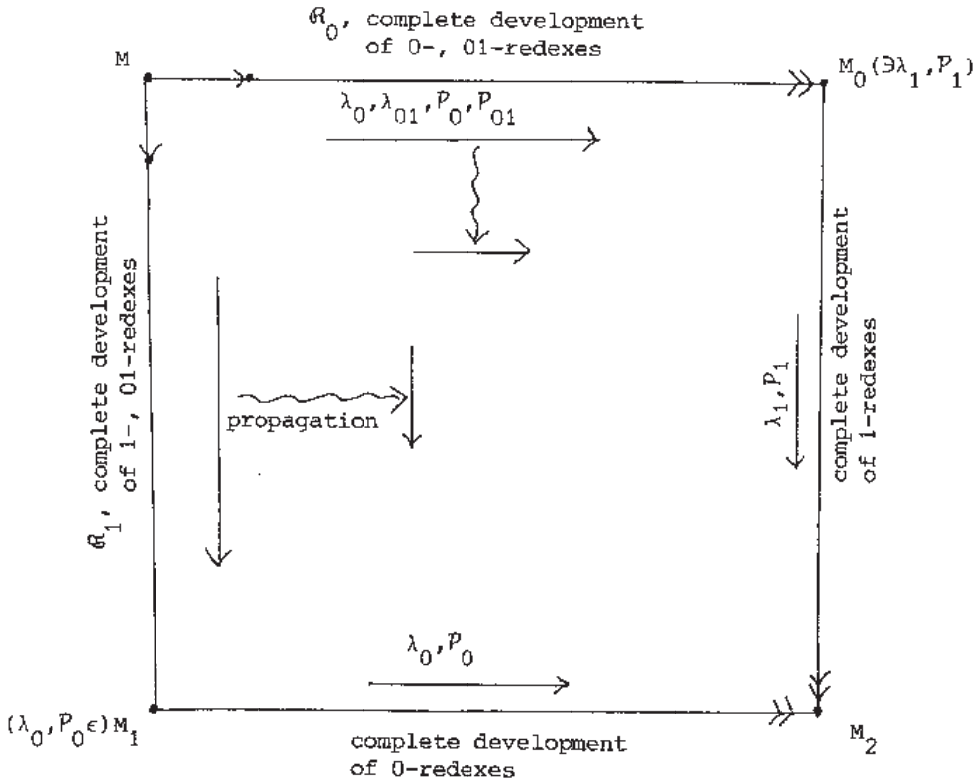

PROOF. Clearly (I) and (II) are equivalent formulations. We will prove (II).

(i) There is an obvious projection  $\Sigma_{01} \rightarrow \Sigma$ , namely replacing  $\lambda_0, \lambda_1, \lambda_{01}$  by  $\lambda$  and  $P_0, P_1, P_{01}$  by  $P$ . So an 'exploding'  $\Sigma_{01}$ -diagram would give rise to an exploding  $\Sigma$ -diagram, in contradiction with the Main Lemma 6.5.

(ii) The steps in  $\mathcal{R}_1$  are contractions of labels 1 or 01, hence for the propagated steps the same holds. Therefore in  $M_0 \rightarrow M_2$  only label 1 contractions can occur since in  $M_0$  there are no labels 01. Likewise for  $\mathcal{R}_0$ .

(iii) Immediate by the fact that in  $M_1$  no label 1, 01 occurs and in  $M_0$  no label 0, 01.  $\square$

As a first corollary of the refined Main Lemma we have

6.9. CHURCH-ROSSER THEOREM.  $\Sigma \models CR^+$ , i.e.: Let  $\mathcal{R} = M \rightarrow M_1 \rightarrow \dots \rightarrow N$  and  $\mathcal{R}' = M \rightarrow M'_1 \rightarrow \dots \rightarrow N'$  be  $\Sigma$ -reductions. Then  $N, N'$  have a common reduct which can be found by the construction of  $\mathcal{D}(\mathcal{R}_1, \mathcal{R}'_2)$ .

PROOF.

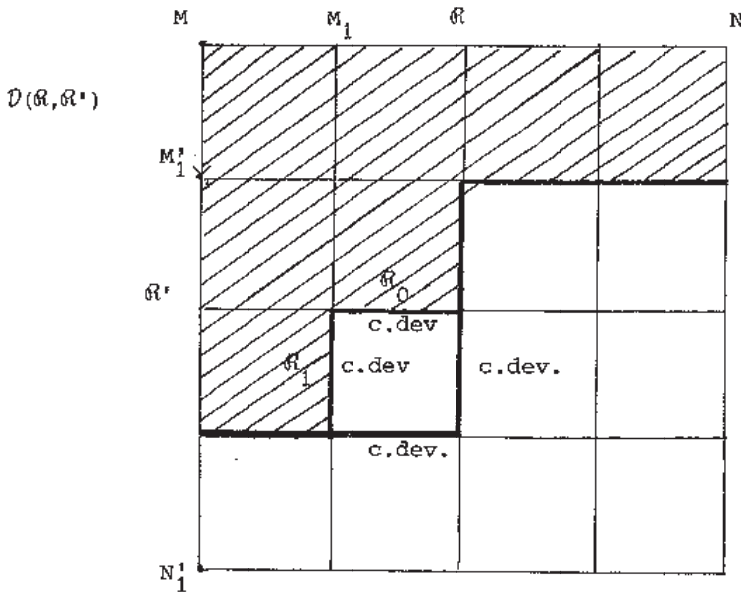

Using the refined Main Lemma we can fill in block by block of the diagram  $\mathcal{D}(\mathcal{R}, \mathcal{R}')$ . Here we use the fact that a single reduction step is trivially a complete development.  $\square$

6.10. NOTATION. (i) If  $\mathcal{R}_1, \mathcal{R}_2$  are two cointial reductions, the right side of  $\mathcal{D}(\mathcal{R}_1, \mathcal{R}_2)$  is denoted by  $\mathcal{R}_2/\mathcal{R}_1$  and will be called the projection of  $\mathcal{R}_2$  by  $\mathcal{R}_1$ . Likewise for the lower side:

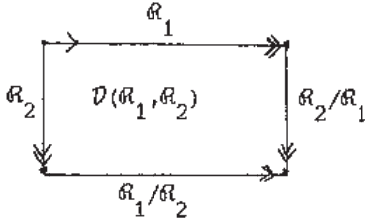

(ii) If  $\mathcal{R}_1 = M \rightarrow \dots \rightarrow N$  and  $\mathcal{R}_2 = N \rightarrow N' \rightarrow \dots$  is a finite or infinite reduction, then  $\mathcal{R}_1 * \mathcal{R}_2$  denotes the concatenation  $M \rightarrow \dots \rightarrow N \rightarrow N' \rightarrow \dots$

(iii) If  $\mathcal{R}$  consists of one step,  $\mathcal{R} = M \xrightarrow{R} N$ , we will write  $\mathcal{R} = \{R\}$ .

6.11. REMARK. Even if  $\mathcal{R}_1$  is infinite and  $\mathcal{R}_2$  is finite, the reduction diagram  $\mathcal{D}(\mathcal{R}_1, \mathcal{R}_2)$  and the projection  $\mathcal{R}_1/\mathcal{R}_2$  are defined.

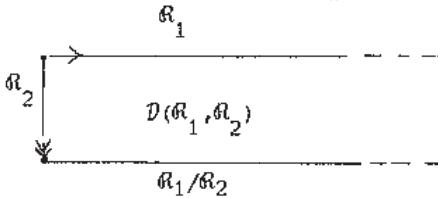

The second corollary of the refined Main Lemma is:

6.12. PARALLEL MOVES LEMMA (PM).

(i) Let in  $M$  some redexes be labeled with  $O$ . Let  $\mathcal{R}_0$  be a complete development (c.dev.) of the  $O$ -redexes, and let  $\mathcal{R}$  be an arbitrary reduction  $M \twoheadrightarrow N$ . (See figure.)

Then  $\mathcal{R}_0/\mathcal{R}$  is a complete development of the  $O$ -redexes in  $N$ .

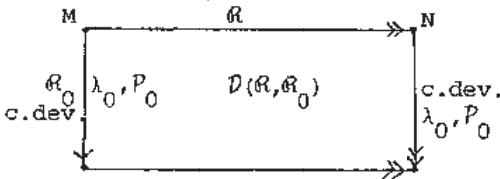

(ii) As a special case of (i) we have:



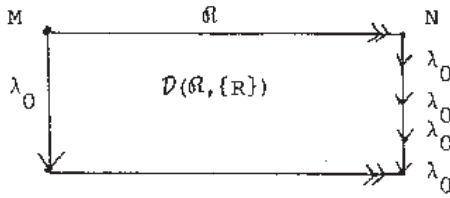

(likewise for  $P_0$  instead of  $\lambda_0$ )

PROOF. (i) Induction on the length of  $R$ .  $\square$

Thirdly, we have at once from the refined Main Lemma:

6.13. COROLLARY. Let  $\Sigma$  be (a substructure of) a definable extension

$\langle \text{Ter}(\lambda P), \xrightarrow{\beta}, \xrightarrow{P_i} \rangle_{i \in J}$ .

Then the reductions  $\xrightarrow{\beta}, \xrightarrow{P_i}$  ( $i \in J$ ) are pairwise commuting (see Definition 5.2.(1)).

6.14. REMARK. By 6.1.3 it is clear that the results of this section generalize immediately to the case where L- or HW- labels or types, as in section 3, are present.

6.15. EXAMPLE. In the next figure an example of a  $\lambda$ -reduction diagram is given:

(Here  $\omega \equiv \lambda x.xx$  and  $R \equiv I_a$ .)

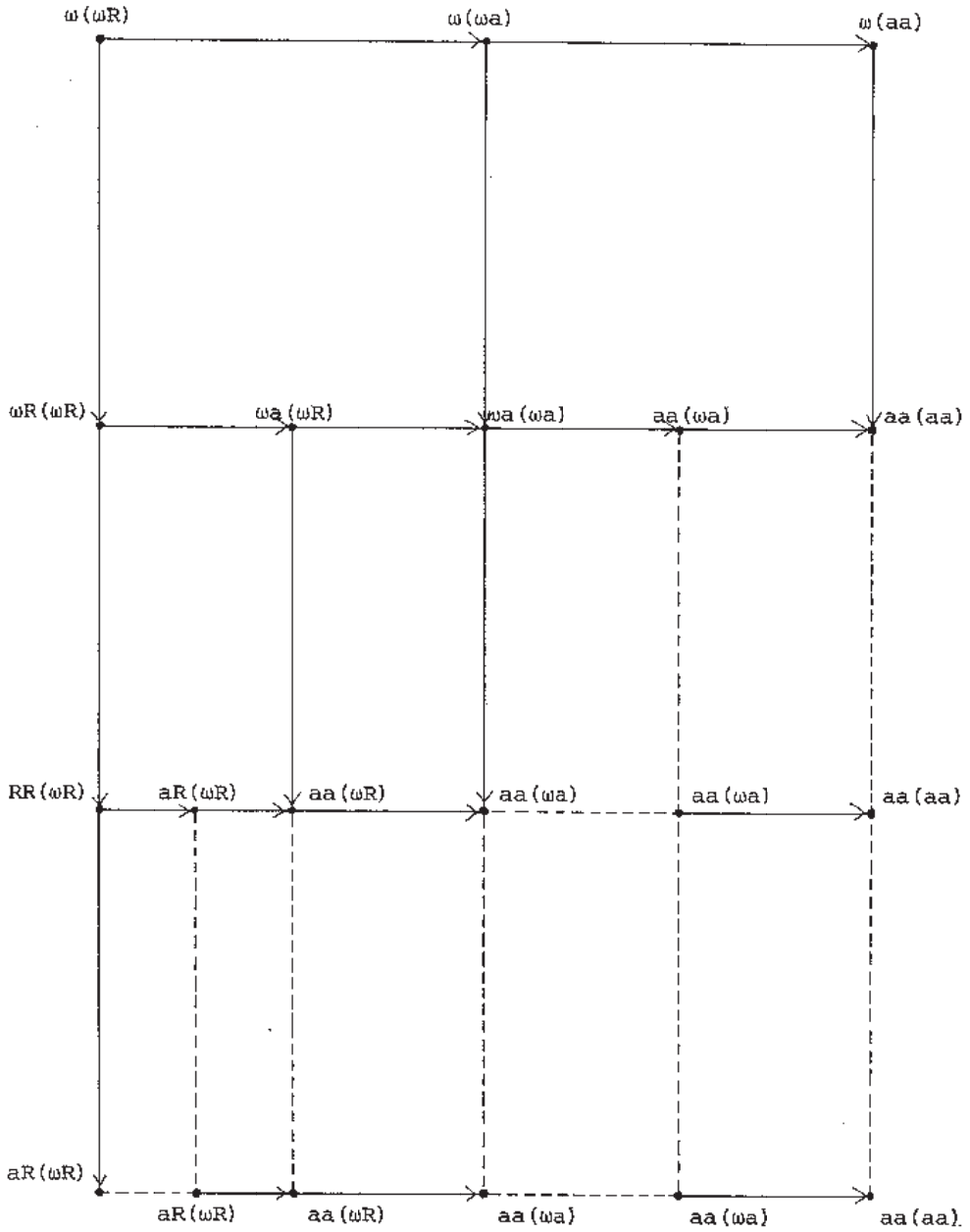

## 7. CHURCH'S THEOREM

A well-known theorem in CHURCH [41] (p.26, 7XXXI) states that for  $\lambda I$ -calculus a term is weakly normalizing (has a normal form) iff it is strongly normalizing. A corollary (p.27, 7XXXII) is that a  $\lambda I$ -term has a normal form iff all its subterms do. For  $\lambda$ -calculus Church's Theorem fails as the term  $(\lambda x.I)\Omega$  (where  $\Omega \equiv (\lambda x.xx)(\lambda x.xx)$  and  $I \equiv \lambda x.x$ ) shows, since in  $(\lambda x.I)\Omega \rightarrow I$  the subterm  $\Omega$  is erased. Intuitively, the reason that  $\lambda I$  satisfies Church's theorem is found in the fact that in  $\lambda I$  there is no erasing possible. I.e. in a reduction step every redex  $R$ , except the one contracted, has at least one residual; in other words, a redex  $R$  cannot be 'thrown away', like  $\Omega$  in the example above, or as in CL:  $KAC[R] \rightarrow A$ . (In fact, we will prove in Chapter II that Church's Theorem holds for all 'regular' Combinatory Reduction Systems which are non-erasing.)

In this section we will prove Church's Theorem for *definable extensions*  $\lambda IP$  of  $\lambda I$ -calculus.

7.1. DEFINITION. Let  $P$  be a set of new constants,  $P = \{P_i \mid i \in I\}$ , and let (as in Def.1.12.1) reduction rules be given for the  $P_i$  ( $i \in J \subseteq I$ ) as follows:

$$P_i A_1 \dots A_n \rightarrow Q_i(A_1, \dots, A_n, P_{j_1}, \dots, P_{j_{n_i}})$$

for some  $Q_i(x_1, \dots, x_n, y_1, \dots, y_{n_i}) \in \text{Ter}(\lambda I)$  such that  $\text{FV}(Q_i) \supseteq \{x_1, \dots, x_n\}$ . (So all the meta-variables  $A_1, \dots, A_n$  occur actually in the RHS of the reduction rule.)

Then the reduction system  $\lambda I$  together with  $P$  and the new reduction rules, is called a *definable extension of  $\lambda I$ -calculus*. We will refer to it as  $\lambda IP$ -calculus.

7.2. EXAMPLES.

- (i)  $\lambda IP$  where  $P = \{I, J\}$  and with the rules  $IA \rightarrow A$ ,  $JABCD \rightarrow AB(ADC)$  is a definable extension of  $\lambda I$ .
- (ii) The set of terms built up from  $I, J$  as in (i) and with the same reduction rules, is the reduction system  $CL_I$  (which is the non-erasing variant of CL, as  $\lambda I$  is the non-erasing variant of  $\lambda$ ).
- $CL_I$  is a substructure of  $\lambda IP$  in (i) in the sense of Def.5.10.(2).
- (iii)  $\lambda I\{P\}$  with the rule  $PABC \rightarrow P(AC)B$  is a definable extension of  $\lambda I$ , which will play a role in the next section.

7.3. REMARK. (i) As in the case of  $\lambda P$ -calculi (definable extensions of  $\lambda$ ), it is not hard to prove that for  $P$  finite, the new constants  $P_i$  plus their reduction rules can be defined in  $\lambda I$ -calculus, using the multiple fixed point theorem for  $\lambda I$ -calculus. Here the condition that the meta-variables  $A_1, \dots, A_n$  occur actually in the RHS of the reduction rule, is essential. (ii) Note that  $\lambda IP$  is non-erasing.

Church's Theorem will be a corollary of the following stronger fact:

7.4. LEMMA. Let  $\Sigma$  be a substructure of a definable extension  $\lambda IP$  of  $\lambda I$ . Let  $\mathcal{R}$  be an infinite reduction in  $\Sigma$  and  $\mathcal{R}' = M \rightarrow \dots \rightarrow N$  a finite reduction in  $\Sigma$ .

Then  $\mathcal{R}/\mathcal{R}'$  is infinite.

PROOF. The proof is a consequence of FD (4.1.11),  $CR^+$  (6.9), PM (6.12) and the fact that there is no erasure in  $\Sigma \subseteq \lambda IP$ .

Clearly it suffices to consider the case that  $\mathcal{R}' = M \xrightarrow{R} N$  is one step, in another notation:  $\mathcal{R}' = \{R\}$ .

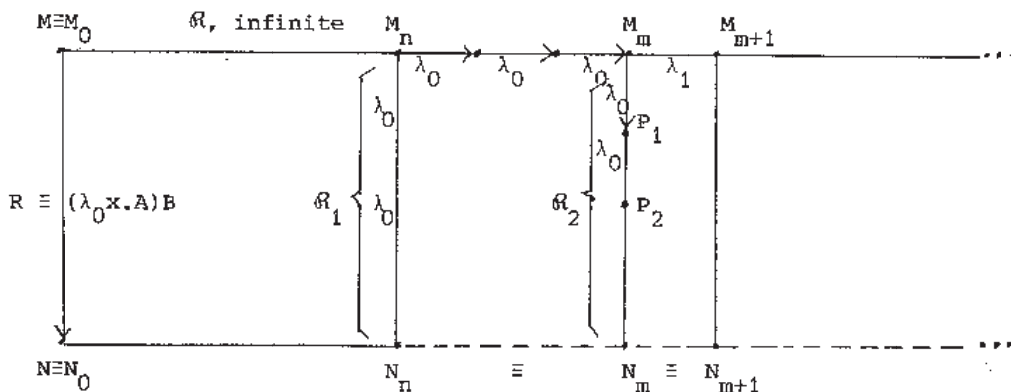

Suppose the lemma does not hold and  $\mathcal{R}/\{R\}$  is finite; say after  $N_n$  it is empty (\*). Assign to the head- $\lambda$  of  $R$  the label 0 and to all the other  $\lambda$ 's in  $M$  the label 1. Then  $\mathcal{R}_1 = M_n \twoheadrightarrow N_n$  is a development of  $\lambda_0$ -redexes (by PM).

Now consider the first step in  $M_n \rightarrow M_{n+1} \rightarrow \dots$  where a  $\lambda_1$ -redex is contracted, say this is  $M_m \rightarrow M_{m+1}$ . (By FD such a step must exist!)  $\mathcal{R}_2 = M_m \twoheadrightarrow N_m$  is again a  $\lambda_0$ -development.

CLAIM.

$$M_m \longrightarrow M_{m+1} / \mathcal{R}_2 \neq \emptyset.$$

Then we have a contradiction with (\*).

PROOF OF THE CLAIM. Since there is no erasure in  $\Sigma$ , there are no elementary diagrams of type

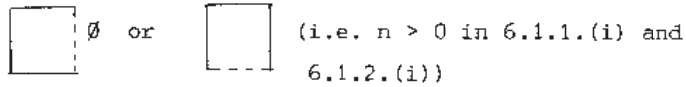

The only possibility for absorption of a step is an e.d.

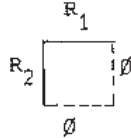

where  $R_1 \equiv R_2$ .

Hence in

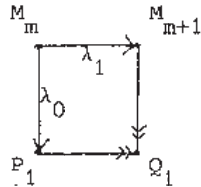

the bottom side is not  $\emptyset$ , since in  $M_m$  the  $\lambda_1$ -redex  $\notin$  the set of  $\lambda_0$ -redexes. So the

bottom side is  $P_1 \longrightarrow P'_1 \twoheadrightarrow Q_1$ . This argument can be repeated for the next e.d.

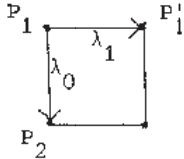

etc. This proves the claim.  $\square$

7.5. COROLLARY (Church's Theorem).

Let  $\Sigma$  be a substructure of a definable extension of  $\lambda I$ -calculus. Let  $M \in \text{Ter}(\Sigma)$ . Then:

(i)  $M \in \text{WN} \iff M \in \text{SN}.$

*In other words: if M has a normal form N, then every reduction of M terminates eventually (in N, by CR).*

(ii)  $M \in \text{WN} \iff \forall M' \subseteq M \quad M' \in \text{WN}$

*(M has a normal form iff all its subterms have a normal form.)*

PROOF. (i)  $\Leftarrow$  is trivial.  $\Rightarrow$ : suppose  $M \in \text{WN}$  but  $M \notin \text{SN}$ . So there is a reduction  $\mathcal{R}' = M \twoheadrightarrow N$  to a normal form N and there is an infinite reduction

$R = M \longrightarrow \dots$

By Lemma 7.4,  $R/R' = N \longrightarrow \dots$  is an infinite reduction. This contradicts the fact that  $N$  is a normal form. (ii) is an easy consequence of (i).  $\square$

7.6. REMARK. In  $\lambda$ -calculus one can ask what happens in a step  $P \xrightarrow{R} Q$  which is 'critical' in the sense that  $P \notin SN$  but  $Q \in SN$ . (So by Lemma 7.4 there are no critical steps in  $\Sigma \subseteq \lambda IP$ .) In BARENDREGT, BERGSTRA, KLOP, VOLKEN[76], Chapter II, it is proved that in such a step the redex  $R$  must be of the form  $(\lambda x.A)B$  where  $x \notin FV(A)$ , i.e.  $R$  erases its argument  $B$ . This result is refined in BERGSTRA, KLOP [78].

### 8. STRONG NORMALIZATION OF LABELED $\lambda$ -CALCULI (VIA $\lambda I$ -CALCULUS)

Introduction. In this section we will prove that  $\lambda^{L,P}$  (for bounded  $P$ ) and its homomorphic images  $\lambda^{HW}$  and  $\lambda^\tau$  have the property of strong normalization (SN), i.e. every  $\lambda^{L,P}$ -reduction (resp.  $\lambda^{HW}, \lambda^\tau$ -) terminates.

(1) Such a proof can probably be given using Tait's method of (strong) computability, although we have not seen yet such a proof for  $\lambda^L$ ; for  $\lambda^{HW}$  this is done by de Vrijer (unpublished) and for  $\lambda^\tau$  (and even for the much stronger system  $\lambda^\tau +$  recursor  $R$ , also called "Gödel's T") this is done in e.g. TROELSTRA [73]. Metamathematically speaking the method has the drawback of using rather strong means, but it is amazingly slick.

(2) Another proof for  $\lambda^L \models SN$  is by a method due to D. van Daalen; see LÉVY [75,78].

(3) For  $\lambda^\tau + R$  there is a proof of Howard, using an ordinal assignment up to  $\epsilon_0$ , but only of WN. It is complicated but constructive, as opposed to Tait's method. See SCHÜTTE [77] §16. (Instead of  $R$ , Schütte uses the iterator  $J$ .)

(4) For  $\lambda^\tau$  (+ numerals and some basic arithmetical functions: successor and addition) a proof of SN was given by Gandy (unpublished) via an interpretation in  $\lambda I^\tau$ , typed  $\lambda I$ -calculus.

(5) Here we will give a proof of SN for the stronger system  $\lambda^L$  also via an interpretation in  $\lambda I^L$ , Lévy-labeled  $\lambda I$ -calculus. Apart from the idea of an interpretation, there seems to be no resemblance with (4).

(6) DE VRIJER [75] and NEDERPELT [73] prove SN for certain  $\lambda$ -calculi (related to the AUTOMATH project of de Bruijn) having  $\lambda$ -terms as types.

(7) After this Chapter was written, we have elaborated the idea of this section in a general setting; see Chapter II. There we use a method due to

NEDERPELT [73] in an essential way.

In fact, the result in this section is a corollary of a general theorem in Chapter II; nevertheless we have maintained this section 8 here since it provides an intuitive idea and an introduction to the part of Chapter II in question.

The next lemma was independently proved by J.J. Lévy (personal communication). By  $\lambda I^{HW}$  we mean  $\lambda I$ -calculus plus Hyland-Wadsworth labels as in 3.7; likewise for  $\lambda I^{L,P}$  ( $\lambda I$ -calculus plus Lévy's labels, see 3.9) and  $\lambda I^T$  (typed  $\lambda I$ -calculus, see 3.8).

8.1. LEMMA.

- (i)  $\lambda I^{HW} \models SN$
- (ii)  $\lambda I^{L,P} \models SN$  for bounded P
- (iii)  $\lambda I^T \models SN$ .

PROOF. We will prove (i); by Proposition 3.9.3 this implies (ii), which implies (iii).

Suppose that there exists an infinite reduction  $\mathcal{R}$  in  $\lambda I^{HW}$ , starting with  $M$ . Now consider a reduction  $\mathcal{R}'$  of  $M$  obtained by repeatedly contracting an innermost redex  $(\lambda x.A)^{n+1} B$ . Such a contraction does not multiply existing redexes (since  $B$  contains none), and the redexes which are created by this contraction, have degree  $< n+1$ . (See 3.7.2.(ii).) Let  $\mathcal{R}'$  be  $M \equiv M_0 \longrightarrow M_1 \longrightarrow \dots$  and assign to  $M_i$  ( $i = 0, 1, \dots$ ) the multiset of degrees of redexes in  $M_i$  (Def.6.4.1). Then, by our previous remark and by Proposition 6.4.2, we see that  $\mathcal{R}'$  must terminate, say in the  $\lambda I^{HW}$ -normal form  $M_n$ .

Now construct the  $\lambda I^{HW}$ -diagram  $\mathcal{D}(\mathcal{R}, \mathcal{R}')$ . (See figure.) By Lemma 7.4 (which holds also in the presence of labels; see Remark 6.11) it follows that  $\mathcal{R}/\mathcal{R}'$  is infinite. But  $M_n$  is a  $\lambda I^{HW}$ -normal form, hence  $\mathcal{R}/\mathcal{R}'$  must be empty. Contradiction.

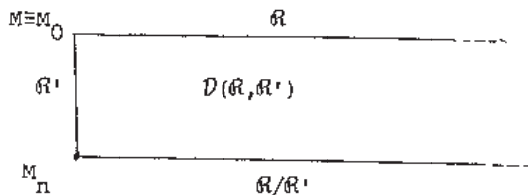

□

8.2. INTUITION. The above simple proof suggests that it might be profitable to interpret  $\lambda^L$  in  $\lambda I^L$ .

Firstly, let us simulate a given reduction  $\mathcal{R} = M \longrightarrow \dots$  in  $\lambda$ -calculus by a reduction  $\mathcal{R}'$  in  $\lambda I$ -calculus as follows. Replace in  $M$  every subterm  $\lambda x.A$  by  $\lambda x.[A,x]$  where  $[,]$  is some pairing operator to be specified later.

Now consider e.g.:

in  $\lambda$ -calculus:  $\mathcal{R} = (\lambda x.I) ABC \longrightarrow IBC \longrightarrow BC \longrightarrow \dots$

in  $\lambda I$ -calculus:  $\mathcal{R}' = (\lambda x.[I,x]) ABC \longrightarrow [I,A] BC \longrightarrow ?$

In order to be able to simulate the second step in  $\mathcal{R}$ , we are led to introduce the rule:  $[M,N]L \rightsquigarrow [ML,N]$ . And now the second step in  $\mathcal{R}$  can be simulated:

$$[I,A]BC \rightsquigarrow [IB,A]C \rightsquigarrow [IBC,A] \longrightarrow [BC,A].$$

In this way we ensure that the 'dummy subterms'  $A$  which are carried along in  $[...,A]$  do not form an obstacle to perform the 'proper' reduction steps which are copied from  $\mathcal{R}$ .

Secondly, we have to add  $L$ -labels. Everything extends to the labeled case in a pleasant way; there is only one 'caveat': the intuition that in  $[A,B]$  the  $A$  is the proper part and  $B$  is the dummy part, suggests that we add the rule for label manipulation

$$[A,B]^\alpha \dashrightarrow [A^\alpha, B].$$

The necessity of this rule can be illustrated by the following example:

$$\begin{array}{ccc} [A,B]^\alpha C & \rightsquigarrow_{\text{not}} & [AC,B]^\alpha \\ \downarrow & & \vdots \\ [A^\alpha, B] C & & \downarrow \\ \downarrow & & \downarrow \\ [A^\alpha C, B] & \neq & [(AC)^\alpha, B] \end{array}$$

8.3. DEFINITION. Let  $\lambda P$  be the definable extension of  $\lambda$ -calculus obtained by adding a constant  $P$  with reduction rule

$$PABC \rightsquigarrow P(AC)B$$



for all  $A, B, C \in \text{Ter}(\lambda P)$ .

8.4. PROPOSITION. Every  $M \in \text{Ter}(\lambda P)$  has a  $P$ -normal form  $M'$ , i.e.  $M'$  contains no  $P$ -redexes and  $M \rightsquigarrow M'$ .

PROOF. Define the tree  $t(M)$  of  $M \in \text{Ter}(\lambda P)$  inductively as follows.

(i)  $t(x) = x$  and  $t(P) = P$

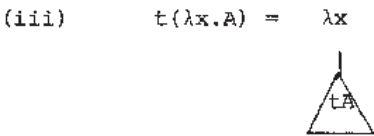
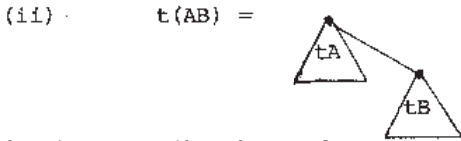

E.g.  $t((\lambda x.Pxx)(yy)(\lambda x.xyP)) =$

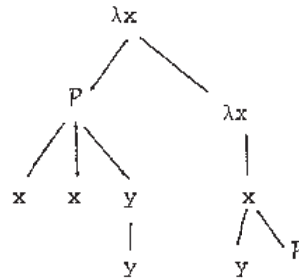

So  $P$ -reduction in tree form looks like:

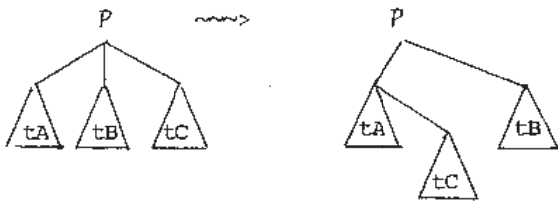

Now consider  $t(M)$  as a partial ordering (p.o.) of its nodes. Then if  $M \rightsquigarrow M'$ , the p.o.'s  $t(M)$  and  $t(M')$  contain just as many points, but in the p.o.  $t(M')$  more pairs of points

are comparable. Hence the proposition follows, since in a p.o. of say  $n$  points the number of comparable pairs is bounded (by  $\binom{n}{2}$ ).  $\square$

We will restrict the set  $\text{Ter}(\lambda\mathcal{P})$  to those terms in which every  $\mathcal{P}$  is followed by at least two arguments. (I.e. every  $\mathcal{P}$  occurs as the head symbol of  $\mathcal{P}A_1A_2\dots A_n$  for some  $A_1, \dots, A_n$  and  $n \geq 2$ .) Furthermore, we will write  $[A,B]$  instead of  $\mathcal{P}AB$ .

8.5. DEFINITION.  $\lambda_{[,\ ]}$  is the reduction system  $\langle \text{Ter}(\lambda_{[,\ ]}), \xrightarrow{B}, \rightsquigarrow \rangle$  where  $\text{Ter}(\lambda_{[,\ ]})$  (the set of terms indicated above) is defined inductively by the clauses

(i), (ii), (iii) similar to Definition 1.1 of  $\text{Ter}(\lambda)$

(iv)  $A, B \in \text{Ter}(\lambda_{[,\ ]}) \Rightarrow [A,B] \in \text{Ter}(\lambda_{[,\ ]})$

and  $\rightsquigarrow$  is defined by  $[A,B]C \rightsquigarrow [AC,B]$ .

(I.e. the translation of the  $\mathcal{P}$ -reduction rule in Definition 8.3.)

A  $[,\ ]$ -normal form is a term in which no  $\rightsquigarrow$ -step is possible.

8.6. DEFINITION. (1)  $\xrightarrow{k}$  is a reduction relation on  $\text{Ter}(\lambda_{[,\ ]})$  defined by

$$[A,B] \xrightarrow{k} A \quad \text{for all } A, B \in \text{Ter}(\lambda_{[,\ ]}).$$

Obviously every  $k$ -reduction ends, in a unique term  $\in \text{Ter}(\lambda)$  (the  $k$ -normal form). The unicity follows from a simple Church-Rosser argument (apply Lemma 5.7.(1) and Theorem 5.11.(2)).

(2)  $\kappa: \text{Ter}(\lambda_{[,\ ]}) \rightarrow \text{Ter}(\lambda)$  is the map defined by

$\kappa: M \mapsto$  the  $k$ -normal form of  $M$ .

(Remark:  $\kappa$  can also directly be defined:

(i)  $\kappa(x) = x$

(ii)  $\kappa(AB) = (\kappa(A)\kappa(B))$

(iii)  $\kappa(\lambda x.A) = \lambda x.\kappa(A)$

(iv)  $\kappa([A,B]) = \kappa(A)$ .

But the propositions about  $\kappa$  in the sequel are easier to prove using  $\xrightarrow{k}$ .)

8.7. PROPOSITION. Let  $A \in \text{Ter}(\lambda_{[,\ ]})$  be in  $[,\ ]$ -nf and let  $A \xrightarrow{k} B$ . Then  $B$  is in  $[,\ ]$ -nf.

PROOF. routine.  $\square$

8.8. PROPOSITION. Let  $A, B, C \in \text{Ter}(\lambda_{[, ]})$  be such that  $A \xrightarrow{k} B \xrightarrow{\beta} C$  and  $A$  is in  $[\text{,}]$ -nf. (See figure.)

Then there is a  $D \in \text{Ter}(\lambda_{[, ]})$  such that  $A \xrightarrow{\beta} D \xrightarrow{k} C$ .

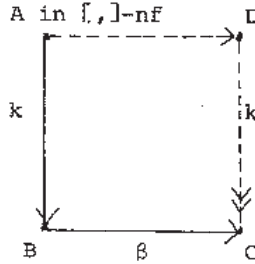

PROOF. Just contract the 'same'  $\beta$ -redex in  $A$  as the one contracted in  $B$ . It is routine to check that this is indeed possible. (We need  $A$  to be in  $[\text{,}]$ -nf, for consider otherwise e.g.:

$$\begin{array}{l}
 A \equiv [I, M]N \\
 \quad \downarrow k \\
 B \equiv IN \xrightarrow{\beta} N \equiv C. \quad \square
 \end{array}$$

8.9. PROPOSITION. Let  $A \in \text{Ter}(\lambda_{[, ]})$  be in  $[\text{,}]$ -nf and  $B, C \in \text{Ter}(\lambda)$  such that  $A \xrightarrow{k} B \xrightarrow{\beta} C$ . Then there is a  $D \in \text{Ter}(\lambda_{[, ]})$  such that  $A \xrightarrow{\beta} D \xrightarrow{k} C$ .

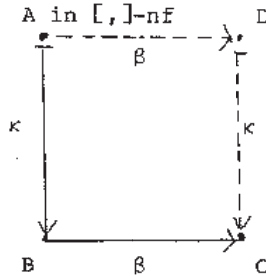

PROOF. Choose an arbitrary  $k$ -reduction from  $A$  to  $B$ :

$$A \xrightarrow{k} A' \xrightarrow{k} A'' \xrightarrow{k} \dots \xrightarrow{k} A^{(n)} \xrightarrow{k} B.$$

Since  $A$  is in  $[\text{,}]$ -nf, by Prop. 8.7 also  $A^{(i)}$  is in  $[\text{,}]$ -nf ( $i = 1, \dots, n$ ).

Now repeated application of the preceding proposition yields: (see figure)

and since  $C$  is a  $k$ -nf (because  $B$  is) we have  $\kappa(D) \equiv C$ .

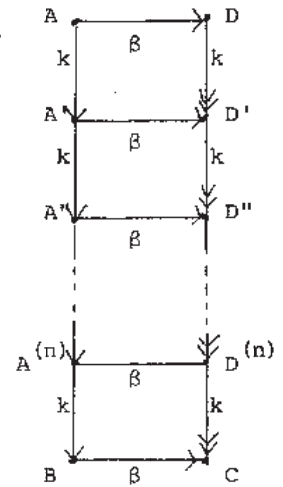

8.10. PROPOSITION. (i) Let  $A, B, C \in \text{Ter}(\lambda_{[\cdot, \cdot]})$  be such that  $C \xleftarrow{k} A \rightsquigarrow B$ . Then  $B \xrightarrow{k} C$  or  $\exists D \ C \rightsquigarrow D \xleftarrow{k} B$ . (See left figure.)

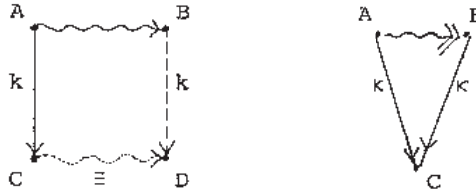

(ii) Let  $A \rightsquigarrow B$ . Then  $\kappa(A) \equiv \kappa(B)$ . (See right figure.)

PROOF.

(i) routine.

(ii) immediately from (i).  $\square$

The next definition is crucial.

8.11. DEFINITION. Let  $\text{Ter}(\lambda I_{[\cdot, \cdot]})$  be the set of  $\lambda_{[\cdot, \cdot]}$ -terms such that in terms of the form  $\lambda x.A$  the variable  $x \in \text{FV}(A)$ .

Now define  $\iota: \text{Ter}(\lambda) \rightarrow \text{Ter}(\lambda I_{[\cdot, \cdot]})$  inductively by

- (i)  $\iota(x) \equiv x$
- (ii)  $\iota(AB) \equiv (\iota(A)\iota(B))$
- (iii)  $\iota(\lambda x.A) \equiv \lambda x.[\iota(A), x]$ .

8.11.1. REMARK. If  $M \in \text{Ter}(\lambda)$ , then obviously  $\kappa \circ \iota(M) \equiv M$ .

8.12. Addition of labels. We want to reconsider 8.5-8.11, now in the presence of L-labels or HW-labels.

Ad 8.5. The definition of  $\lambda_{[ , ]}^L$ -terms is an unproblematic union of the definitions of  $\lambda^L$ -terms (3.9) and of  $\lambda_{[ , ]}$ -terms (8.5).

Reduction in  $\lambda_{[ , ]}^L$  is given by:

$$(i) \quad (\lambda x.A)^\delta_B \longrightarrow [x := B^\delta]A^\delta$$

$$(ii) \quad [x := A]x^\alpha \equiv A^\alpha$$

$$(iii) \quad (A^\alpha)^\beta \longrightarrow A^{\alpha\beta}$$

$$(iv) \quad [A, B]^\alpha \longrightarrow [A^\alpha, B]$$

$$(v) \quad [A, B]C \rightsquigarrow [AC, B]$$

for all  $A, B, C \in \text{Ter}(\lambda_{[ , ]}^L)$  and  $\alpha, \beta, \delta \in L$ . Reductions (iii), (iv) which concern the manipulation of labels, are not considered as 'proper' reductions; we will execute them immediately whenever possible (hence we work in fact with  $\longrightarrow$  - normal forms). In this way we ensure moreover what we need in (v) (see the last example in 8.2), viz. that a subterm  $[A, B]$  must be unlabeled.

Ad 8.6(1) Define:  $[A, B] \xrightarrow{\kappa_L} A$  for all  $A, B \in \text{Ter}(\lambda_{[ , ]}^L)$ .

Ad 8.6(2):

Define  $\kappa_L$  similar as before. The reader may convince himself that the extension of the Propositions 8.7-8.10 to the labeled case is entirely straightforward and unproblematic. We will only present the extension of  $\iota$  to the labeled case:

Ad 8.11. Let  $\iota_L: \text{Ter}(\lambda^L) \longrightarrow \text{Ter}(\lambda_{[ , ]}^L)$  be defined by:

$$(i) \quad \iota_L(x) \equiv x.$$

$$(ii) \quad \iota_L(AB) \equiv \iota_L(A) \iota_L(B)$$

$$(iii) \quad \iota_L(\lambda x.A) \equiv \lambda x. [\iota_L(A), x]$$

$$(iv) \quad \iota_L(A^\alpha) \equiv (\iota_L(A))^\alpha$$

Now we get the  $[ , ]$ -analogue of lemma 8.1:

8.13. LEMMA.  $\lambda_{[ , ]}^{L, P}$  ( $P$  bounded  $\models$  SN, likewise  $\lambda_{[ , ]}^{HW}$  and  $\lambda_{[ , ]}^T$ ).

PROOF. Suppose an infinite reduction  $\mathcal{R} = M \longrightarrow \dots$  in  $\lambda I_{[,] }^{L,P}$  is given. As before, in 8.1, we find a terminating reduction  $\mathcal{R}'$  of  $M$  by contraction of innermost redexes, where after each  $\beta$ -step we take the  $[, ]$ -nf:

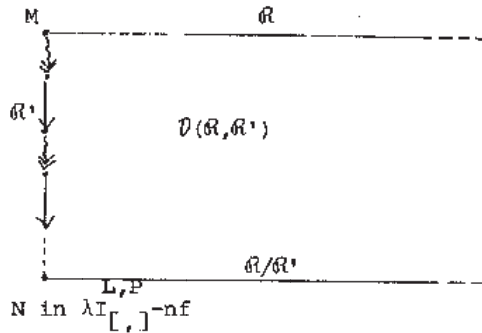

Applying Church's theorem 7.5 on  $\lambda I_{[,] }^{L,P}$ , a substructure of a definable extension of  $\lambda I$ , yields:  $\mathcal{R}/\mathcal{R}'$  is infinite. Contradiction.  $\square$

Finally we can collect the fruits of our labor:

8.14. THEOREM.  $\lambda^{L,P}$  ( $P$  bounded),  $\lambda^{HW}$ ,  $\lambda^T \models SN$ .

PROOF. Suppose an infinite reduction  $\mathcal{R} = M \xrightarrow{\beta_L} \dots$  in  $\lambda^{L,P}$  is given. Let  $N \equiv \nu_L(M)$ ; by Remark 8.11.1 we have  $\kappa_L(N) \equiv M$ . (See figure below.) Now repeated application of the (according to 8.12) labeled versions of Propositions 8.9 and 8.10(ii) yields an infinite reduction  $\mathcal{R}'$  in  $\lambda I_{[,] }^{L,P}$  as in the figure. But this contradicts Lemma 8.13. Hence  $\lambda^{L,P} \models SN$ ; for the other two reduction systems  $SN$  follows from this, as before.

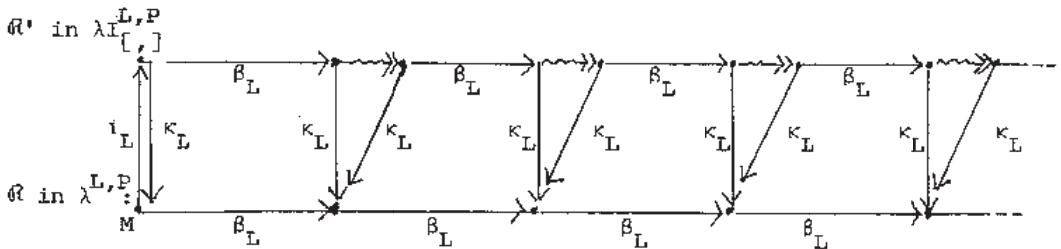

$\square$

## 9. STANDARDIZATION

In this section we will give the first of two new proofs of the well-known Standardization Theorem for  $\lambda\beta$ -calculus. This proof extends (see 9.10) also to definable extensions of  $\lambda$ -calculus; but in 9.1 - 9.7 we will consider only  $\lambda\beta$ -calculus, for notational simplicity. In Chapter IV the same method will be used to prove the Standardization Theorem for  $\lambda\beta\eta$ -calculus.

In fact we will prove (see 9.8.3) a strong version of the Standardization Theorem, due to LÉVY [78]. To this end, in 9.8 Lévy's concept of 'equivalence of reductions' will be introduced.

9.1. DEFINITION. *Standard reductions*

A reduction  $\mathcal{R} = M_0 \rightarrow M_1 \rightarrow \dots$  (finite or infinite) is *standard* if the successive redex contractions take place from left to right.

More precisely: let  $*$  be an auxiliary symbol to be attached to some redex- $\lambda$ 's:  $(\lambda^* x.A)B$ , indicating that it is henceforth forbidden to contract this redex. Now the reduction  $\mathcal{R}$  is provided with markers  $*$  by the following inductive definition.

Suppose up to  $M_{n-1}$  the markers are attached. Consider the step  $M_n \xrightarrow{R_n} M_{n+1}$  where  $R_n$  is the contracted redex. Mark

- (i) every  $\lambda$  in  $M_n$  which descends from a  $\lambda^*$  in  $M_{n-1}$
- (ii) every  $\lambda$  in  $M_n$  to the left of the head- $\lambda$  of  $R_n$ , if not yet marked by (i).

Now we define:  $\mathcal{R}$  is *standard* if no marked redex is contracted in  $\mathcal{R}$ .

9.1.1. REMARK. (1) It is equivalent to require in (ii): every redex- $\lambda$  in  $M_n$  to the left of ... and so on.

(2) It is easy to see that this definition is equivalent to the usual one, as in HINDLEY [78], in terms of residuals - but we find that the use of  $*$  facilitates our way of speaking.

(3) Hindley distinguishes '*weakly standard*' and '*strongly standard*'. His '*strongly standard*' is the above concept '*standard*'. Hindley proved that for the  $\lambda\beta$ -calculus the two concepts coincide, see HINDLEY [78].

9.2. DEFINITION. Let  $\mathcal{R} = M_0 \xrightarrow{R_0} M_1 \xrightarrow{R_1} \dots$  be a finite or infinite reduction sequence. A redex  $R \subseteq M_0$  is *contracted in  $\mathcal{R}$*  if for some  $n \in \mathbb{N}$ ,  $R_n$  is a residual of  $R$ .

## 9.2.1. NOTATION.

- (i)  $\text{lmc}(\mathcal{R})$  is the *leftmost* redex in  $M_0$  that is contracted in  $\mathcal{R}$ .
- (ii)  $p(\mathcal{R}) = \mathcal{R}/\{\text{lmc}(\mathcal{R})\}$ , i.e.  $p(\mathcal{R})$  is the projection of  $\mathcal{R}$  by the contraction of the redex  $\text{lmc}(\mathcal{R})$ .
- (iii) If  $s, s' \in M$ , then  $s < s'$  means:  $s$  is to the left of  $s'$ .  
If  $S, S' \subseteq M$ , then  $S < S'$  means: the headsymbol of  $S$  is to the left of that of  $S'$ .

## 9.3. DEFINITION of the standardization procedure

Let  $\mathcal{R} = M_0 \rightarrow M_1 \rightarrow \dots \rightarrow M_n$  be a given reduction sequence. Define by induction a reduction sequence  $\mathcal{R}_s$  as follows:

$$\mathcal{R}_s = M_0 \xrightarrow{\text{lmc}(\mathcal{R})} M'_1 \xrightarrow{\text{lmc}(p\mathcal{R})} M'_2 \xrightarrow{\text{lmc}(p^2\mathcal{R})} M'_3 \dots,$$

a possibly infinite sequence. It stops when there is no  $\text{lmc}(p^n\mathcal{R})$  for some  $n$ , i.e. when  $p^n\mathcal{R} = \emptyset$ .

We will show that  $\mathcal{R}_s$  is "the" standard reduction for  $\mathcal{R}$ ; that is,  $\mathcal{R}_s$  is a standard reduction  $M_0 \rightarrow \dots \rightarrow M_n$  which is moreover equivalent to  $\mathcal{R}$  in a sense later to be specified.

The construction of  $\mathcal{R}_s$  is illustrated in the next figure.  $\mathcal{D}_s$  is the corresponding "standardization diagram".

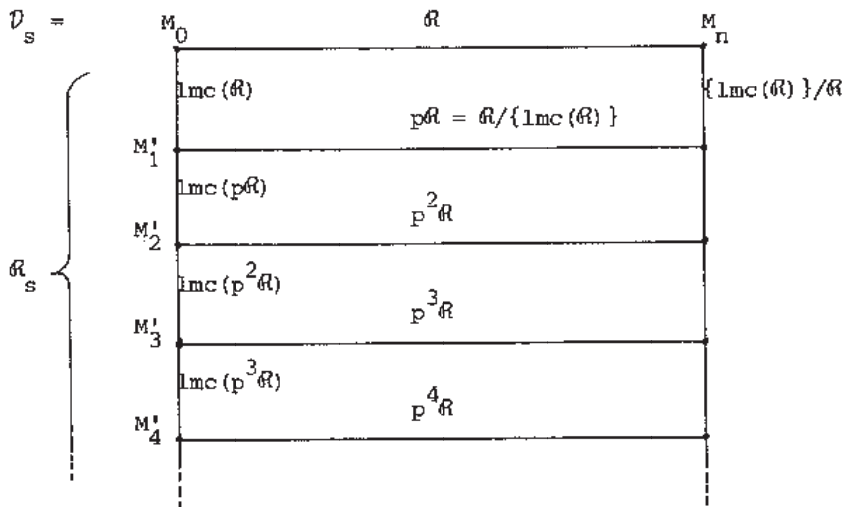



9.4. PROPOSITION.  $\{\text{lmc}(\mathcal{R})\}/\mathcal{R} = \emptyset$  (consists of empty steps.)

PROOF. Immediately by the Parallel Moves Lemma 6.12; let  $R$  in the figure there be  $\text{lmc}(\mathcal{R})$ . The head- $\lambda$  of  $R$ ,  $\lambda_0$ , is clearly not multiplied in  $\mathcal{R}$ , since it is  $\text{lmc}(\mathcal{R})$ . Hence after the unique  $\lambda_0$ -contraction in  $\mathcal{R}$ , no  $\lambda_0$  is present, in particular not in  $M_n$ . By PM,  $\{R\}/\mathcal{R}$  must be therefore empty.  $\square$

9.5. COROLLARY. The right side of  $\mathcal{D}_S$  is empty.  $\square$

9.6. LEMMA.  $\mathcal{R}_S$  is finite.

PROOF. We will use the labeled  $\lambda^{\text{HW}}$ -calculus as introduced in 3.7.

Let us recall the main properties of these labels:

- (i) every subterm of a given  $\lambda$ -term has a label  $\epsilon \in \mathbb{N}$  written as superscript.
- (ii) the degree of a redex  $((\lambda x.A)^a_B)^d_r$  is  $d$ .
- (iii) indexed reduction is defined as in 3.7; for the application here we need only to recall that contraction of a redex is allowed iff its degree is  $> 0$ .
- (iv) in an indexed reduction residuals of a redex with degree  $d$ , have again degree  $d$ .
- (v) Strong Normalization (SN) for indexed reduction: every indexed reduction terminates.
- (vi) every finite reduction  $\mathcal{R} = M_0 \rightarrow \dots \rightarrow M_n$  can be extended to an indexed reduction, by choosing sufficiently large indexes for  $M_0$  and 'taking these along' through  $\mathcal{R}$ . Similarly for two finite cointitial  $\mathcal{R}_1, \mathcal{R}_2$ .

Now take an indexing for  $\mathcal{R}$  (by vi). By (iv)  $\text{lmc}(\mathcal{R})$  has the degree of the residual of  $\text{lmc}(\mathcal{R})$  which is contracted in  $\mathcal{R}$ ; i.e. a positive degree. Therefore the indexing can be extended to all of the diagram  $\mathcal{D}(\{\text{lmc}(\mathcal{R})\}, \mathcal{R})$ . Hence the bottom side of this diagram,  $\mathcal{R}'$ , is again indexed. And so forth. In this way the indexing of  $\mathcal{R}$  determines a unique indexing of the whole diagram  $\mathcal{D}_S$ . Thus in particular  $\mathcal{R}_S$  is indexed; hence by (v) it terminates.  $\square$

9.6.1. REMARK. Instead of using SN for  $\lambda^{\text{HW}}$  to prove the termination of  $\mathcal{R}_S$ , one can alternatively use FD (the theorem of Finite Developments, 4.1.11). The proof using FD is somewhat longer; in outline it is as follows (for a complete proof see BARENDREGT [80]).

Suppose  $\mathcal{R}_s$  is infinite. Then for some  $k$ , the projection of  $\mathcal{R}_s$  by  $M_0 \rightarrow \dots \rightarrow M_k$  is infinite (see figure), i.e. contains infinitely many non-empty steps, while the projection of  $\mathcal{R}_s$  by  $M_0 \rightarrow \dots \rightarrow M_{k+1}$  is finite, i.e. contains only  $\emptyset$  steps after some term  $B$ .

Let  $\mathcal{R}_1, \mathcal{R}_2, \mathcal{R}_3$  be as in the figure. Now by PM(6.12),  $\mathcal{R}_2$  is a development.

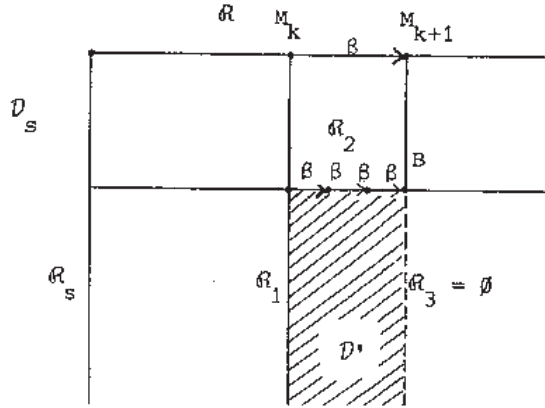

Furthermore, it is not hard to prove that the step  $\{lmc(\mathcal{R})\}$  propagates to the right, without splitting, until it is "absorbed" as follows:

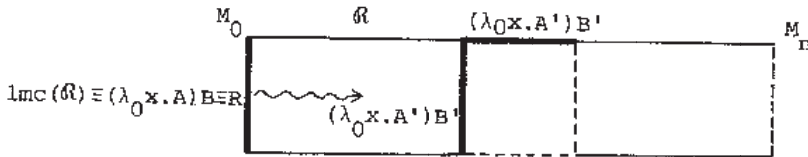

Using this, and the fact that  $\mathcal{R}_2$  is a development, one can easily show that also  $\mathcal{R}_1$  must be a development; hence, by FD,  $\mathcal{R}_1$  is finite. Contradiction. Hence  $\mathcal{R}_s$  is finite.  $\square$

9.7. STANDARDIZATION THEOREM. Let  $\mathcal{R}$  be a finite reduction. Then  $\mathcal{R}_s$  is a standard reduction for  $\mathcal{R}$ , i.e.

- (i)  $\mathcal{R}$  and  $\mathcal{R}_s$  have the same first and last term, and
- (ii)  $\mathcal{R}_s$  is standard.

PROOF. (i) is almost trivial: since  $\mathcal{R}_s$  is finite, the construction of the diagram  $\mathcal{D}_s = \mathcal{D}(\mathcal{R}_s, \mathcal{R})$  terminates, hence  $\mathcal{D}_s$  has a bottom side,  $\mathcal{R}/\mathcal{R}_s$ . This bottom side is empty, for otherwise  $\mathcal{R}_s$  would have gone further, by its definition.

(ii) Attach markers  $*$  in  $\mathcal{R}_s$  as described in Def.9.1. Suppose  $\mathcal{R}_s$  is not

standard. Let  $M'_m$  be the first term in  $\mathcal{R}_s$  such that in the step  $M'_m \rightarrow M'_{m+1}$  a marked redex  $R$  is contracted. Let  $M'_n$  be the term in  $\mathcal{R}_s$  in which the (unique) ancestor  $R'$  of this redex is marked for the first time. Label all the  $\lambda$ 's in  $M'_n$  with distinct labels such that  $\lambda_0$  is the head- $\lambda$  of  $R'$ , and extend this labeling throughout the diagram in the figure.

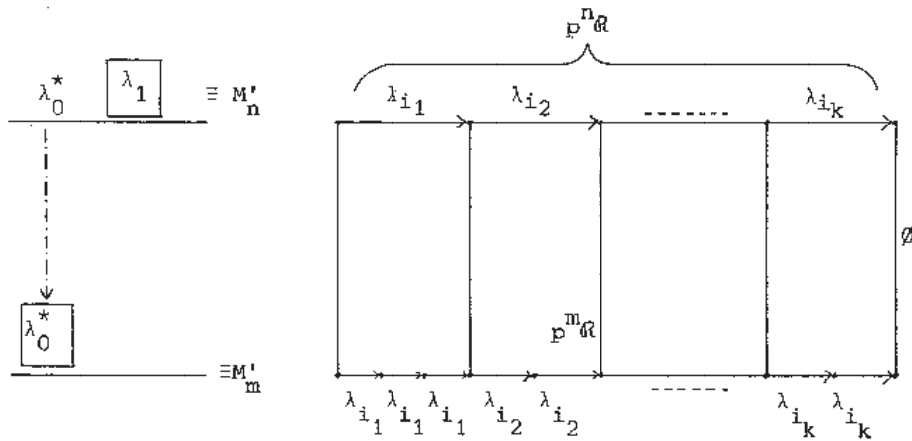

Now  $\lambda_1$ , the redex contracted in  $M'_n \rightarrow M'_{n+1}$ , is  $> \lambda_0$  in  $M'_n$ , since  $\lambda_0$  was marked in  $M'_n$  for the first time. Hence  $0 \notin \{i_1, \dots, i_k\}$ , because otherwise  $\lambda_0$  or a  $\lambda < \lambda_0$  should have been  $\text{lmc}(p^n R)$ .

By the PM Lemma (6.12), the contracted labels in  $p^m R$  form a subset of  $\{i_1, \dots, i_k\}$ . Hence no  $\lambda_0$  can be contracted in  $p^m R$ , contradicting the assumption that  $R \equiv (\lambda_0 x.A)B \equiv \text{lmc}(p^m R)$ .  $\square$

9.7.1. REMARK. By the same method, one can also prove the 'completeness of inside-out reductions', as it is called in WELCH [75] and LÉVY [75]. Here the definition of 'inside-out reduction' (not to be confused with 'innermost' reduction) is analogous to Definition 9.1 of 'standard' reduction: replace in Def.9.1 the relation  $<$  ('to the left of') by  $\subseteq$  ('subterm of'). So instead of 'freezing' all redexes  $<$  the contracted redex by attaching the marker  $*$ , we freeze all redexes  $\subseteq$  the contracted redex.

Now we have:

PROPOSITION. If  $M \xrightarrow{\beta} N$ , then there is an inside-out reduction  $M \xrightarrow{\beta}^{\text{i.o.}} L$  such that  $N \xrightarrow{\beta} L$ .

Since there is a short and elegant proof of the proposition in LÉVY [75] Thm.4, using  $\lambda^L$ , we will give only a sketch:

Define, analogous to the definition of  $\mathcal{R}_s$ , a reduction  $\mathcal{R}_{\text{i.o.}}$  by repeated

contraction of an "innermost contracted redex" (instead of the "leftmost contracted redex").

The proof that such an  $\mathcal{R}_{i.o.}$  (not uniquely determined now, as  $\mathcal{R}_s$  was) terminates and is an inside-out reduction indeed, is entirely analogous to the corresponding proofs for  $\mathcal{R}_s$ . Now let  $\mathcal{D}_{i.o.}$  be the reduction diagram corresponding to the construction of  $\mathcal{R}_{i.o.}$ ; then the bottom side is, as before,  $\emptyset$ . However, the right side of  $\mathcal{D}_{i.o.}$  will be in general not empty. So we have

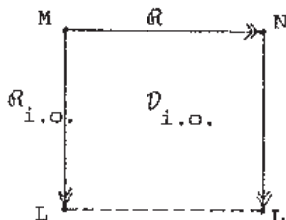

which proves the proposition.  $\square$

9.8. Equivalence of reductions. In fact we have just proved something more than Theorem 9.7 as it stands. In order to formulate this, we will introduce Lévy's notion of 'equivalent reductions'. The notion is intuitively clear and ties up nicely with  $\lambda^L$ . (In the next section it will be compared with some other notions of equivalence for reductions.)

Suppose that  $\mathcal{R}_1, \mathcal{R}_2$  are finite reductions such that  $\mathcal{R}_2/\mathcal{R}_1 = \emptyset$ . This means that in  $\mathcal{D}(\mathcal{R}_1, \mathcal{R}_2)$  the steps coming from  $\mathcal{R}_2$  (propagating to the right) are "absorbed" by those of  $\mathcal{R}_1$  (propagating downwards). In an intuitive sense one can say:  $\mathcal{R}_1$  does the same things as  $\mathcal{R}_2$  and possibly more. Therefore:

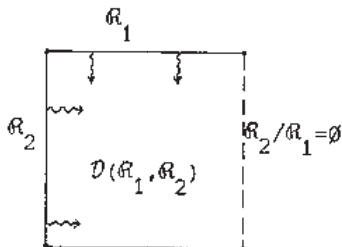

9.8.1. DEFINITION (LÉVY [78] 2.1.p.37).

- (i)  $\mathcal{R}_1 \geq \mathcal{R}_2 : \iff \mathcal{R}_2/\mathcal{R}_1 = \emptyset$ .
- (ii)  $\mathcal{R}_1 \simeq_L \mathcal{R}_2 : \iff \mathcal{R}_1 \geq \mathcal{R}_2 \ \& \ \mathcal{R}_2 \geq \mathcal{R}_1$ .  
( $\mathcal{R}_1, \mathcal{R}_2$  are 'Lévy-equivalent')

9.8.2. REMARK. (1) It is not hard to prove that  $\simeq_L$  is indeed an equivalence relation; the transitivity is ensured by the 'cube lemma' (see LÉVY [78] 2.2.1).

(2) *Warning:* if  $\mathcal{R}_2 * \mathcal{R}_3$  and  $\mathcal{R}$  have the same first and last term, it does not follow that  $\mathcal{R}_2 \leq \mathcal{R}_1$ . The notion of diagram is essential here. Counterexample:

$$\mathcal{R}_1 = \Omega(\text{II}) \rightarrow \Omega\text{I}, \quad \mathcal{R}_2 = \Omega(\text{II}) \rightarrow \Omega(\text{II}), \quad \mathcal{R}_3 = \Omega(\text{II}) \rightarrow \Omega\text{I}.$$

For then  $\mathcal{R}_2/\mathcal{R}_1 = \Omega\text{I} \rightarrow \Omega\text{I} \neq \emptyset$ .

(3) Lévy uses a slightly different but equivalent definition of  $\mathcal{R}_1/\mathcal{R}_2$  and of  $\mathcal{D}(\mathcal{R}_1, \mathcal{R}_2)$  (not using our e.d.'s).

Now we can prove the strong version of the Standardization Theorem for  $\lambda\beta$ -calculus:

9.8.3. STANDARDIZATION THEOREM (Strengthened version, Lévy).

Let  $\mathcal{R}$  be a finite reduction sequence. Then  $\mathcal{R}_s$  is the unique standard reduction for  $\mathcal{R}$  such that  $\mathcal{R}_s \simeq_L \mathcal{R}$ .

PROOF. (i)  $\mathcal{R}_s \simeq_L \mathcal{R}$  is a direct consequence of the definition of  $\simeq_L$ ; for indeed in the standardization diagram  $\mathcal{D}_s$  both the right side and the lower side were empty.

(ii) Unicity. Suppose  $\mathcal{R}^0$  is another standard reduction with the same first and last term as  $\mathcal{R}$ , such that  $\mathcal{R} \simeq_L \mathcal{R}^0$ . Then, because  $\mathcal{R}_s \simeq_L \mathcal{R}$  and because  $\simeq_L$  is transitive, we have  $\mathcal{R}^0 \simeq_L \mathcal{R}_s$ .

Now suppose that

$$\mathcal{R}_s = M_0 \xrightarrow{R_0} \dots \xrightarrow{R_{k-1}} M_k \xrightarrow{R_k} M_{k+1} \longrightarrow \dots \longrightarrow M_n$$

and

$$\mathcal{R}^0 = M_0 \xrightarrow{R_0} \dots \xrightarrow{R_{k-1}} M_k \xrightarrow{R'_k} M'_{k+1} \longrightarrow \dots \longrightarrow M'_n,$$

where  $R_k \neq R'_k$  (as always: the occurrence of  $R_k \neq \text{occ. of } R'_k$ ).

Then, testing whether  $\mathcal{D}(\mathcal{R}^0, \mathcal{R}_s)$  has empty bottom and right side, we have the following situation:

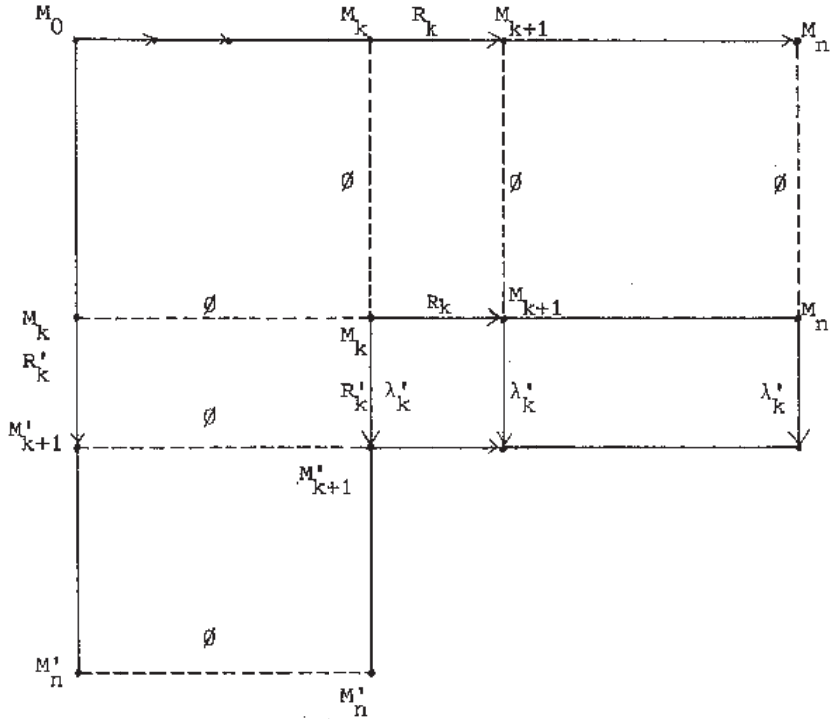

Suppose  $M_k \equiv \frac{\lambda'_k}{\lambda_k}$  where  $\lambda_k, \lambda'_k$  are the head- $\lambda$ 's of  $R_k$  and  $R'_k$  and  $\lambda'_k < \lambda_k$ . (The other case follows by symmetry.)

Now it is clear, using that  $M_k \xrightarrow{R_k} \dots M_n$  is standard, that  $\lambda'_k$  propagates without splitting or becoming absorbed. Hence the right side of  $\mathcal{D}(R^0, R_S)$  is not  $\emptyset$ , hence  $R^0 \not\equiv_L R_S$ , contradiction.  $\square$

9.9. REMARK. All the facts in this section 9 generalize to definable extensions  $\lambda P$  of  $\lambda$ -calculus. In Def. 9.1: "frozen"  $P$ -redexes  $\vec{P}A$  are marked as  $P^{\vec{A}}$ ; 9.2 - 9.5 also extend immediately. At this moment, the proof of Lemma 9.6 does not seem to generalize to  $\lambda P$ , since we used  $\lambda^{HW} \models SN$  and for  $\lambda P$  in general we have not yet a HW- or L-labeling available. However, in Chapter II.6.2.7.15, we will extend Theorem 8.14, stating that  $\lambda^{HW, \lambda^{L,P}} \models SN$ , to a class of reduction systems containing the definable extensions. Then also the proof of Lemma 9.6 generalizes to  $\lambda P$ . Even now we have the Standardization Theorem for  $\lambda P$ , since in Lemma 9.6 we could alternatively use FD (see Remark 9.6.1).

The notion of Lévy-equivalence, the 'cube lemma' for  $\lambda P$ , and the strong version of the Standardization Theorem (9.8.3) also carry over, as one easily checks.

9.10. REMARK. There is a close connection between  $\lambda^L$  and  $\simeq_L$ , which is extensively studied in LÉVY [78]. We mention a few points: the reduction graph  $G(M^I)$  of a Lévy-labeled term  $M^I$ , is isomorphic with  $\text{RED}(M)/\simeq_L$ , the set of finite reductions of  $M$  modulo  $\simeq_L$ . The reduction graph  $G(M)$  of the unlabeled term  $M$ , is a homomorphic image of  $\text{RED}(M)/\simeq_L$ ; that there is no isomorphism between those structures is because there are 'syntactical accidents', as Lévy calls them. The paradigm of such a syntactical accident is:  $I(Ix) \xrightarrow{\quad} Ix$ ; in two, clearly not Lévy-equivalent, ways  $I(Ix)$  is reduced to the same result. For more examples of this sort, see our Examples 10.1.1.

LÉVY [78] gives furthermore information about  $\text{RED}(M)/\simeq_L$  in terms of lattices; e.g. they are not complete but can be completed by taking also infinite reductions of  $M$  into account. As an example consider the lattice (not complete)  $\text{RED}(M)/\simeq_L$  where  $M \equiv (\lambda x. \text{Ka}(x(\omega_3 \omega_3)))(\text{Kb})$ . Here  $\text{Ka} \equiv \lambda x. a$  and  $\omega_3 \equiv \lambda x. xxx$ . It is isomorphic with  $G(M)$ , since there are no syntactical accidents here.  $\text{RED}(M)/\simeq_L$  can be completed by adding two points, i.e.

$\mathcal{R}_1/\simeq_L$  and  $\mathcal{R}_2/\simeq_L$  where  $\mathcal{R}_1 = M \rightarrow \dots \omega_3 \omega_3 \omega_3 \dots \rightarrow \dots \omega_3 \omega_3 \omega_3 \omega_3 \dots$  and  $\mathcal{R}_2 = M \rightarrow \text{Ka}(\text{Kb}(\omega_3 \omega_3)) \rightarrow \text{Ka}(\text{Kb}(\omega_3 \omega_3 \omega_3)) \rightarrow \text{Ka}(\text{Kb}(\omega_3 \omega_3 \omega_3 \omega_3)) \rightarrow \dots$  (infinite reductions).

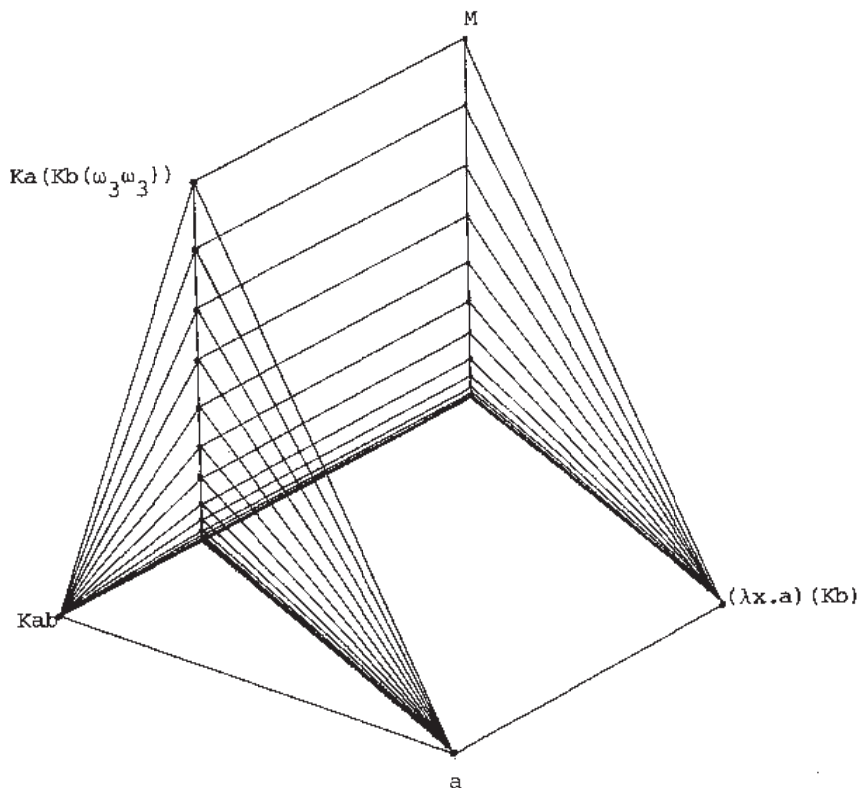

Reduction graph of  $M \equiv (\lambda x. \text{Ka}(x(\omega_3 \omega_3)))(\text{Kb})$ .

## 10. STANDARDIZATION AND EQUIVALENCE OF REDUCTIONS

In this section we give a second new proof of the Standardization Theorem, thereby demonstrating a close connection between Lévy-equivalence of reductions as introduced in Def. 9.8.1, and standardization. We start with comparing in 10.1 several definitions of equivalence which have been proposed in the literature. In 10.2 we continue with  $\approx_L$  and show that it can be generated by a 'meta-reduction  $\Rightarrow$ ' between finite reductions  $\mathcal{R}_1, \mathcal{R}_2$  with fixed first and last term.  $\mathcal{R}_1 \Rightarrow \mathcal{R}_2$  will mean that  $\mathcal{R}_2$  is 'more standard' than  $\mathcal{R}_1$ . The reduction  $\Rightarrow$  has the following properties:

- (1) it is strongly normalizing,
- (2) it has the CR property,
- (3) the ' $\Rightarrow$ -normal forms' are exactly the standard reductions,
- (4) it generates  $\approx_L$  as equivalence relation.

Moreover, we obtain a simple proof of the Standardization Theorem.

When writing this section, we realized that Prop. 2.2.9 in LÉVY [78], due to Berry, is roughly the same as (4) above. A closely related idea is stated in BERRY-LÉVY [79]; see our remark after 10.2.6. There however the direction in  $\Rightarrow$  is not considered, and (hence) neither the connection with standardization.

In 10.3 we make some remarks on the cardinality of an equivalence class  $[\mathcal{R}]_{\approx_L}$ .

### 10.1. Some definitions of equivalence between finite reduction sequences

#### 10.1.0. DEFINITION.

- (i)  $\mathcal{R} \sim \mathcal{R}' \iff \mathcal{R}, \mathcal{R}'$  have the same first and last term. (HINDLEY [78'] calls such  $\mathcal{R}, \mathcal{R}'$  *weakly equivalent*.)
- (ii) Let  $\mathcal{R} = M_0 \longrightarrow \dots \longrightarrow M_n$ . Then:  $\mathcal{R} \sim_R \mathcal{R}' \iff \mathcal{R} \sim \mathcal{R}'$  & for every redex  $R \subseteq M_0$ , the residuals of  $R$  via  $\mathcal{R}$  coincide with those of  $R$  via  $\mathcal{R}'$ . (This definition is introduced by HINDLEY [78'], who calls such  $\mathcal{R}, \mathcal{R}'$  *strongly equivalent*.)
- (iii)  $\mathcal{R} \sim_S \mathcal{R}' \iff \mathcal{R} \sim \mathcal{R}'$  & for every subterm  $S \subseteq M_0$  the descendants of  $S$  via  $\mathcal{R}$  coincide with those of  $S$  via  $\mathcal{R}'$ . (This definition is proposed by C. Wadsworth in private communication to H. Barendregt.)
- (iv)  $\mathcal{R} \sim_s \mathcal{R}' \iff \mathcal{R} \sim \mathcal{R}'$  & for every symbol  $s \in M_0$  the descendants of  $s$  via  $\mathcal{R}$  coincide with those of  $s$  via  $\mathcal{R}'$ .





Now

	$R'$	$R''$
$R$	$\sim_R \not\sim_S \not\sim_L$	$\sim_R \sim_S \not\sim_L$
$R'$		$\sim_R \not\sim_S \not\sim_L$

(ix) In general, let  $C$  be a cyclic reduction:  $C = M_0 \longrightarrow \dots \longrightarrow M_n \equiv M_0$ .  
 Let  $C^{(i)} = C * C * \dots * C$  ( $i$  times). Here  $*$  denotes concatenation of reductions.

Then (1)  $\forall_{i,j} \quad i \neq j \Rightarrow C^{(i)} \not\sim_L C^{(j)}$

(2)  $\exists_{i,j} \quad i \neq j \ \& \ C^{(i)} \sim_S C^{(j)}$ .

PROOF. (1) Follows directly from the definitions.

(2) Is a direct consequence of the fact that there are only finitely many binary relations on the set of subterms of  $M_0$ . (and ' $\dots$  descends to  $\dots$ ' is a binary relation.)  $\square$

10.1.2. THEOREM.

$$\begin{array}{c}
 (i) \quad \sim_B \xleftrightarrow{(1)} \sim_L \xleftrightarrow{(2)} \approx \\
 \quad \quad \quad \Downarrow (3) \\
 \quad \quad \quad \sim_S \xleftrightarrow{(4)} \sim_S \\
 \quad \quad \quad \Downarrow \\
 \quad \quad \quad \sim_R \\
 \quad \quad \quad \Downarrow \\
 \quad \quad \quad \sim
 \end{array}$$

(ii) *The implications under (i) are the only ones.*

PROOF. (i) (1): see LÉVY [78] p.41,42

(2) is proved in Theorem 10.2.6 below;

(3) is easily proved by tracing the subterms (or symbols) in reduction diagrams, starting with the elementary diagrams;

(4)  $(\Rightarrow)$  follows since most of the symbols in a term are also subterms (except  $\lambda$ , and brackets);

$(\Leftarrow)$  follows since either a subterm is a variable (hence a symbol) or else it is compound, and hence determined by its outermost brackets. Then apply the hypothesis to those bracket symbols.

The non-numbered implications are trivial.

(ii) That no more implications hold, follows from the preceding examples (example (viii) suffices).  $\square$

10.1.3. REMARK. Note that all the equivalences considered in Theorem 10.1.2 have the following pleasant property:

*Any two cointial reductions ending in a normal form, are equivalent.*

PROOF. Immediately, via  $\approx_L$ .  $\square$

10.2. Standard reductions and  $\approx_L$

10.2.1. DEFINITION. An anti-standard pair (a.s.pair) of reduction steps is a reduction consisting of two steps, which is not standard.

10.2.1.1. REMARK. Obviously, if  $\mathcal{R} = M \xrightarrow{\lambda_1} M' \xrightarrow{\lambda_2} M''$  is an a.s. pair, then  $M \equiv \frac{\lambda_2 \lambda_1}{\lambda_2 \lambda_1}$  where  $\lambda_1, \lambda_2$  are the head- $\lambda$ 's of  $\beta$ -redexes and  $\lambda_2 < \lambda_1$ .

10.2.2. DEFINITION. (i) RED is the set of all finite reduction sequences.

(ii) The 'meta-reduction'  $\Rightarrow$  on RED is defined as follows:

(1) If  $\mathcal{R} = M \xrightarrow{\lambda_1} M' \xrightarrow{\lambda_2} M''$  is an a.s. pair, then  $\mathcal{R} \Rightarrow \mathcal{R}'$ , where

$$\mathcal{R}' = M \xrightarrow{\lambda_2} M''' \xrightarrow{\lambda_1} \xrightarrow{\lambda_1} \xrightarrow{\lambda_1} M''.$$

$\underbrace{\hspace{10em}}_{n \geq 0 \text{ times}}$

(2) If  $\mathcal{R} \Rightarrow \mathcal{R}'$ , then  $\mathcal{R}_1 * \mathcal{R} * \mathcal{R}_2 \Rightarrow \mathcal{R}_1 * \mathcal{R}' * \mathcal{R}_2$ .

(iii)  $\Rightarrow$  is the transitive reflexive closure of  $\Rightarrow$ .

$\approx$  is the equivalence relation generated by  $\Rightarrow$ , called *permutation equivalence*.

10.2.2.1. REMARK. Note the connection between  $\Rightarrow$  and the elementary diagrams introduced in 6.1.1, as suggested by the following figure (where  $\lambda_2 < \lambda_1$ ):

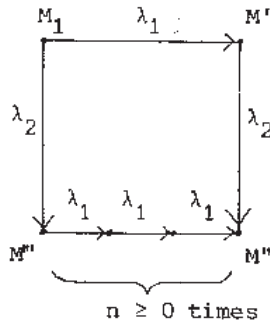

10.2.2.2. PROPOSITION. (LÉVY [78] 2.2.6 Prop.p.40).

$\mathcal{R}_1 * \mathcal{R}_2 / \mathcal{R}_1 \simeq_L \mathcal{R}_2 * \mathcal{R}_1 / \mathcal{R}_2$ . I.e.: let  $\mathcal{R}$  be the right-upper reduction of a reduction diagram  $\mathcal{D}$  and  $\mathcal{R}'$  be the left-lower reduction of  $\mathcal{D}$ ; then  $\mathcal{R} \simeq_L \mathcal{R}'$ .

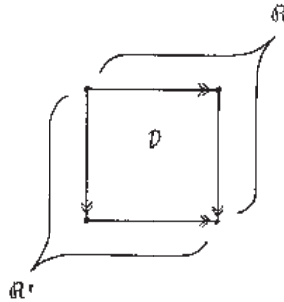

PROOF. Simply by 'folding out'  $\mathcal{D}$ :

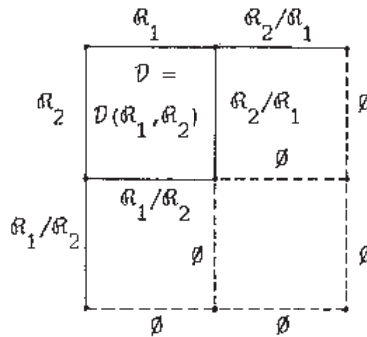

Hence indeed  $\mathcal{R} = \mathcal{R}_1 * (\mathcal{R}_2 / \mathcal{R}_1) \simeq_L \mathcal{R}' = \mathcal{R}_2 * (\mathcal{R}_1 / \mathcal{R}_2)$ .  $\square$

10.2.2.3. REMARK. Let  $\mathcal{R}$  be an a.s. pair and let  $\mathcal{R} \Rightarrow \mathcal{R}'$ . Then  $\mathcal{R} \simeq_L \mathcal{R}'$ , as is evident from Remark 10.2.2.1 and the preceding proposition.

10.2.2.4. PROPOSITION (LÉVY [78] Prop.2.2.4).

If  $\mathcal{R} \simeq_L \mathcal{R}'$ , then  $\mathcal{R}_1 * \mathcal{R} * \mathcal{R}_2 \simeq_L \mathcal{R}_1 * \mathcal{R}' * \mathcal{R}_2$ .

PROOF. Immediate, by the following diagram construction:

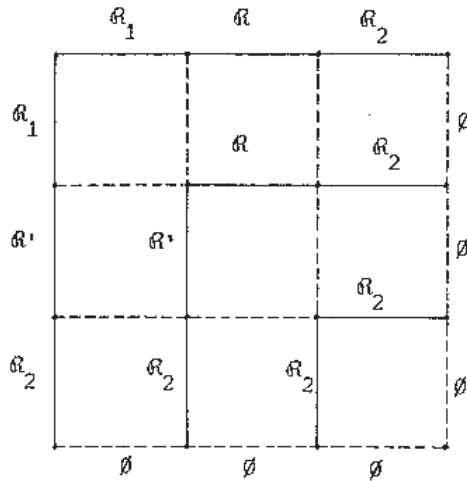

□

10.2.2.5. LEMMA. If  $R \approx R'$  then  $R \simeq_L R'$ .

PROOF. If  $R \Rightarrow R'$ , then  $R \simeq_L R'$  follows by Remark 10.2.2.3 and Proposition 10.2.2.4.

From this, and the transitivity of  $\simeq_L$  (LÉVY [78] 2.2.3) the lemma follows. □

10.2.3. PROPOSITION.  $\Rightarrow$  is acyclic.

PROOF. Suppose not; that is: there is a  $\Rightarrow$ -reduction

$R_0 \Rightarrow R_1 \Rightarrow \dots \Rightarrow R_n = R_0$ . We prove by induction on  $|R_0|$ , the number of steps of  $R_0$ , that such a  $\Rightarrow$ -cycle cannot exist. (\*). The *basis* step of the induction is trivial.

*Induction hypothesis*: suppose (\*) is true for  $|R_0| \leq m$ . Now let  $|R_0| = m+1$ .

Suppose for some  $\ell < n$  the permuted a.s. pair is at the *beginning* of  $R_\ell$ , as displayed below; and let  $\ell$  be the *least* such number. Then  $\lambda_1 < \lambda_0$ , and the final reduction  $R_n$  must begin with the contraction of a  $\lambda_2 \leq \lambda_1 < \lambda_0$ . Hence  $R_n \neq R_0$ .

If there is no such  $\ell$ , then erasing the first step in  $R_0, \dots, R_n$  yields again a  $\Rightarrow$ -cycle  $R'_0 \Rightarrow \dots \Rightarrow R'_n = R'_0$  where  $|R'_0| = m$ ; contradiction. □

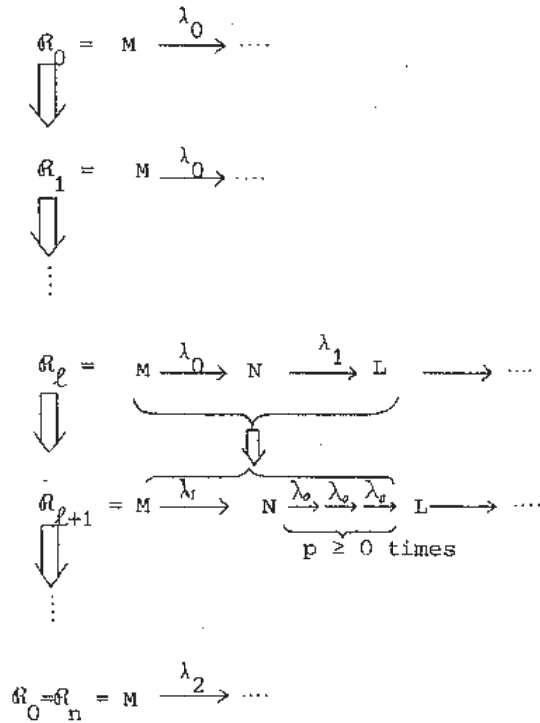

10.2.3.1. REMARK. Note that  $\mathcal{R}_0 = I_1(I_2x) \xrightarrow{I_2} I_1x \xrightarrow{I_1} x$   
 $\Downarrow$   
 $\mathcal{R}_1 = " \xrightarrow{I_1} I_2x \xrightarrow{I_2} x$

is not a  $\Rightarrow$ -cycle, since we are considering reductions together with the specification of contracted redexes. Hence  $\mathcal{R}_0 \neq \mathcal{R}_1$ .

10.2.4. DEFINITION. Let  $\mathcal{R} = M \longrightarrow \dots \longrightarrow N$  be a finite reduction. Then the labeling  $I$  of  $M$  is *adequate* for  $\mathcal{R}$  iff  $\mathcal{R}$  can be extended to a labeled reduction  $M^I \longrightarrow \dots \longrightarrow N^J$ , which will be called  $\mathcal{R}^I$ .

10.2.4.1. PROPOSITION. Let  $\mathcal{R} = M \longrightarrow \dots \longrightarrow N$ . Then there is a labeling  $I$  of  $M$  which is adequate for  $\mathcal{R}$ .

PROOF. Easy.  $\square$

10.2.5. THEOREM. (i) The reduction  $\Rightarrow$  is strongly normalizing (i.e. every sequence  $\mathcal{R} \Rightarrow \mathcal{R}' \Rightarrow \mathcal{R}'' \Rightarrow \dots$  terminates).

(ii) 'The  $\Rightarrow$ -normal forms' are the standard reductions.

PROOF. (i) Suppose that there is an infinite sequence  $\mathcal{R}_0 \Rightarrow \mathcal{R}_1 \Rightarrow \dots$ , let  $I$  be a labeling which is adequate for  $\mathcal{R}_0$ ;

$$\mathcal{R}_0^I = M^I \longrightarrow \dots \quad (\text{by Prop.10.2.4.1, } I \text{ exists}).$$

Now it is easy to see that the labeling  $I$  of  $M^I$  is also adequate for  $\mathcal{R}_1 = M \longrightarrow \dots$ ; we have only to check that things work for an a.s. pair, as follows.

Consider the figure

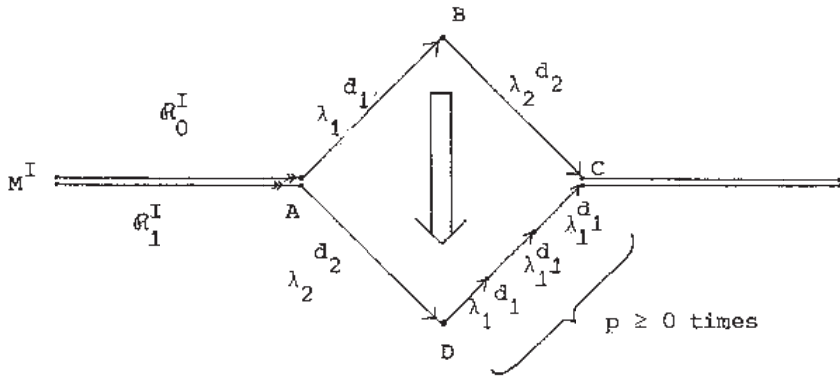

Here it immediately follows (from the fact that residuals of a redex  $(\lambda x.P)^d$  have again the same degree  $d$ ) that the degrees of the redexes contracted from  $A$  to  $D$  to  $C$  are the same as the degrees  $d_1, d_2$  of the redexes contracted from  $A$  to  $B$  to  $C$ . Further, the labeling  $I$  was adequate for  $\mathcal{R}_0$ , hence  $d_1, d_2 > 0$ . Hence  $I$  is also adequate for  $\mathcal{R}_1$ .

So the supposed infinite sequence extends to the infinite sequence of labeled reductions

$$\begin{array}{ccccccc} \mathcal{R}_0^I & \Longrightarrow & \mathcal{R}_1^I & \Longrightarrow & \mathcal{R}_2^I & \Longrightarrow & \dots \\ \parallel & & \parallel & & \parallel & & \\ M^I & & M^I & & M^I & & \\ \downarrow & & \downarrow & & \downarrow & & \\ \vdots & & \vdots & & \vdots & & \end{array}$$

Now by SN for labeled reduction (Theorem 8.14), every labeled reduction starting from  $M^I$  must terminate. Hence, by Königs Lemma, there are only finitely many such reductions. Hence the sequence  $R_0^I \Rightarrow R_1^I \Rightarrow \dots$  must contain a cycle. Contradiction with Prop.10.2.3.

PROOF of (ii). Suppose  $R$  is not standard. Claim: then  $R$  contains an a.s. pair. For, let

$$R = M_0 \longrightarrow \dots \longrightarrow M_{k-1} \xrightarrow{\lambda_{k-1}} M_k \xrightarrow{\lambda_k} M_{k+1} \longrightarrow \dots \longrightarrow M_n$$

$\underbrace{\hspace{15em}}_{\text{a.s. pair}}$

where  $k$  is the least number s.t.  $M_0 \longrightarrow \dots \longrightarrow M_{k+1}$  is not standard. Then it is not hard to see that  $M_{k-1} \longrightarrow M_k \longrightarrow M_{k+1}$  is an a.s. pair.

From the claim it follows immediately that the endpoints of maximal  $\Rightarrow$ -sequences are standard reductions.  $\square$

2.5.1. COROLLARY (Standardization theorem).

$$\forall R \exists R' \quad R \sim R' \quad \& \quad R' \text{ is standard.}$$

PROOF. Every  $\Rightarrow$ -reduction of  $R$  leads to a standard reduction  $R'$  for  $R$ , by theorem 10.2.5.  $\square$

Next we will show that every maximal  $\Rightarrow$ -reduction of  $R$  ends in a unique standard reduction  $R'$  for  $R$ . We can proceed in two ways: prove directly that  $\Rightarrow$  has the WCR property, by means of checking several cases:

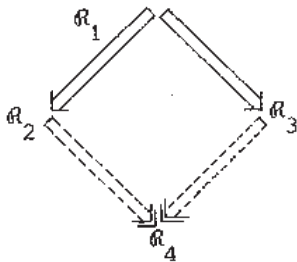

i.e.  $\forall R_1, R_2, R_3$ : if  $R_2 \Leftarrow R_1 \Rightarrow R_3$  then  
 $\exists R_4 \quad R_2 \Rightarrow R_4 \Leftarrow R_3$

Then by Newman's Lemma 5.7. (1) we have CR and hence UN (Uniqueness of Normal form) for  $\Leftarrow$ . The other way is as follows.

10.2.6. THEOREM.  $R \approx R' \iff R \simeq_L R'$ .



PROOF. ( $\Rightarrow$ ) is Lemma 10.2.2.5.

( $\Leftarrow$ ) Suppose  $R \approx_L R'$ , so  $\mathcal{D}(R, R')$  is like:

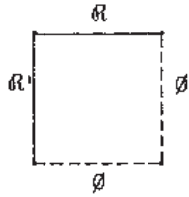

We will show that one can directly read off a 'conversion', say  $R \Leftarrow \Rightarrow \Leftarrow \dots \Rightarrow \Leftarrow R'$ , from  $\mathcal{D}(R, R')$ .

Remember the 'construction of diagrams' (6.1), which proceeded as in the figure, by adjoining elementary diagrams:

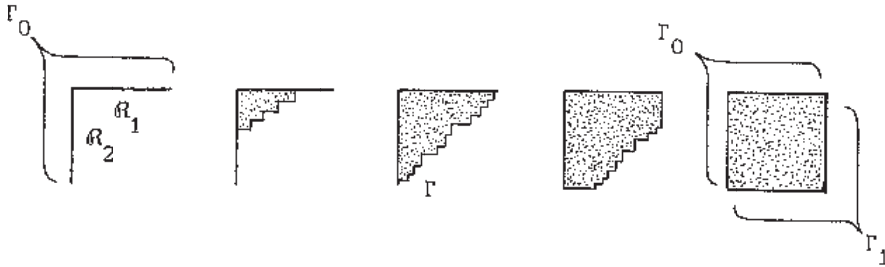

Here  $R_1, R_2$  are the two given coinital reductions; the 'conversion' (i.e. a sequence of  $\rightarrow$  and  $\leftarrow$ )  $\Gamma_0 = \leftarrow \xrightarrow{R_2, R_1} \rightarrow$  'reduces' to the conversion  $\Gamma_1$  via  $\Gamma$ .

Now suppose we have the completed diagram  $\mathcal{D}(R_1, R_2)$  available, and consider the following procedure of again filling up the diagram; but now starting from the upper right corner:

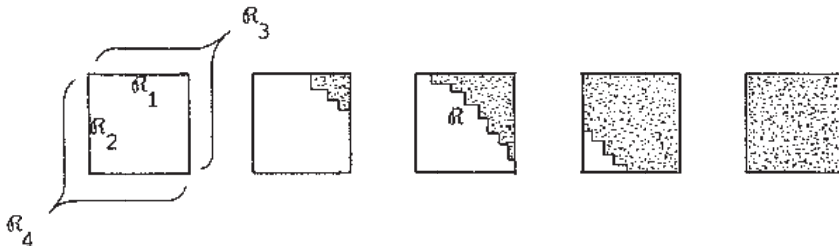

This 'dual' procedure is in fact a  $\Rightarrow$ -conversion of the reduction  $R_3$  to  $R_4$  via  $R$ . That is, every adjunction of an elementary diagram  $\square$  corresponds either to

(1) a  $\Rightarrow$ -reduction step, in case  $\square$  is



$p \geq 0$  times

or (2) an  $\Leftarrow$ -expansion, in case  $\square$  is



$p \geq 0$   
times

or (3) a trivial step, in case  $\square$  is

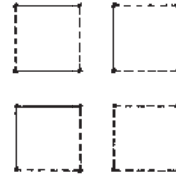

So filling up  $\mathcal{D}(\mathcal{R}_1, \mathcal{R}_2)$  in this way yields a  $\Rightarrow$ -conversion, interlaced with trivial steps, of reductions which are also interlaced with trivial steps. Omitting all the trivial steps, one gets the desired proper  $\Rightarrow$ -conversion from  $\mathcal{R}_3 = \mathcal{R}_1 * (\mathcal{R}_2/\mathcal{R}_1)$  to  $\mathcal{R}_4 = \mathcal{R}_2 * (\mathcal{R}_1/\mathcal{R}_2)$ .

In particular, for the  $\mathcal{R}, \mathcal{R}'$  s.t.  $\mathcal{R} \simeq_{\mathcal{L}} \mathcal{R}'$  we have a  $\Rightarrow$ -conversion between them.  $\square$

Before formulating the corollaries of this theorem, we need the

**10.2.7. PROPOSITION.** Let  $\mathcal{R}_1, \mathcal{R}_2$  be standard reductions and suppose that  $\mathcal{R} \simeq_{\mathcal{L}} \mathcal{R}_2$ . Then  $\mathcal{R}_1 = \mathcal{R}_2$ .

**PROOF.** This is Prop.2.3.2 in LÉVY [78] p.43. We have also proved it, in Theorem 9.8.3.(ii).  $\square$

**10.2.8. COROLLARY.** (i) Every  $\approx$ -equivalence class contains a unique ' $\Rightarrow$ -normal form' (i.e. standard reduction).

(ii)  $\Rightarrow$  is CR

(iii) Standardization Theorem, strenghtened version:

For every  $\mathcal{R}$  there is a unique standard reduction  $\mathcal{R}' \approx \mathcal{R}$ .

**PROOF.** (i), (iii). Consider an equivalence class  $[\mathcal{R}]_{\approx} = \{\mathcal{R}'/\mathcal{R} \approx \mathcal{R}'\}$ . By Theorem 10.2.4.(i) there is at least one ' $\Rightarrow$ -normal form' in  $[\mathcal{R}]_{\approx}$ . Now suppose there are two different  $\Rightarrow$ -normal forms  $\mathcal{R}_1, \mathcal{R}_2$  as in the figure below.

By Theorem 10.2.5(ii),  $\mathcal{R}_1, \mathcal{R}_2$  are standard. By definition of  $\approx$ ,  $\mathcal{R}_1 \approx \mathcal{R}_2$ , and hence by Theorem 10.2.6  $\mathcal{R}_1 \simeq_{\mathcal{L}} \mathcal{R}_2$ . Therefore, by Proposition 10.2.7,  $\mathcal{R}_1 = \mathcal{R}_2$ .

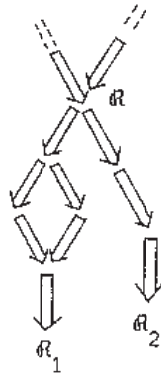

(ii) We have just proved the uniqueness of  $\Leftrightarrow$ -normal forms (UN). Together with SN for  $\Rightarrow$  (Theorem 10.2.5(i)) this yields CR (by Lemma 5.7.(2)).

10.2.8.1. REMARK. (i) Corollary 10.2.8.(i) and (iii) are due to LÉVY [78]; see 2.3.4 Corollaire.

(ii) Theorem 10.2.6 is very close to Prop.2.2.9, due to G. Berry, in LÉVY [78] p.41, where it is proved that  $\approx_B = \approx_L$ ; or Prop.I.2.7 p.25 in BERRY-LÉVY [79] where the analogous fact for 'Recursive Program Schemes' is proved. The theorem is even closer to a remark on p.25 of BERRY-LÉVY [79]: "In fact, it is possible to generalize this congruence only by the permutation lemma of I.1.4". This remark amounts to: for Recursive Program Schemes,  $\approx_L$  coincides with the equivalence generated by  $\Leftrightarrow$ , where  $\Leftrightarrow$  is the symmetric closure of  $\Rightarrow$  for RPS's.

10.2.9. REMARK. Note the following correspondence between the present proof of the Standardization Theorem and the proof in section 9: in the latter proof we had the 'standardization diagram'

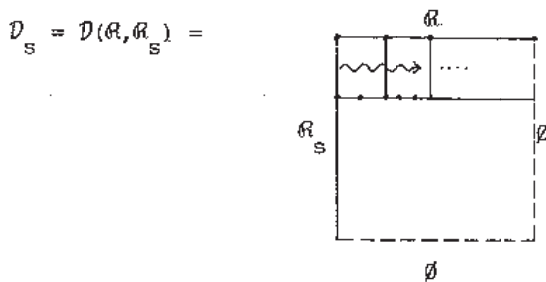

having the property that steps moving to the right (see the figure above), do not split. Otherwise said, case (2) in the proof of Theorem 10.2.6 does not apply here. Hence the above procedure yields not only a  $\Rightarrow$ -conversion

from  $\mathcal{R}$  to  $\mathcal{R}_s$ , but even a  $\Rightarrow$ -reduction from  $\mathcal{R}$  to  $\mathcal{R}_s$ : (see figure)

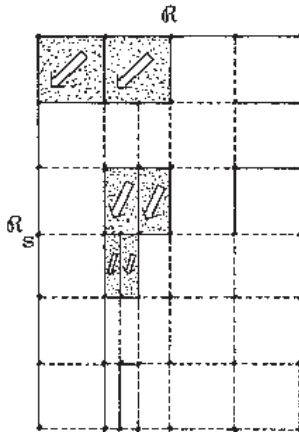

$\mathcal{R}$  reduces to  $\mathcal{R}_s$  in six proper  $\Rightarrow$ -steps.

From the proof of theorem 10.2.6 we obtain the following

10.2.10. COROLLARY. Let  $\mathcal{R}', \mathcal{R}''$  be two reduction paths in a diagram  $\mathcal{D}(\mathcal{R}_1, \mathcal{R}_2)$  having the same begin and end point. Then  $\mathcal{R}' \approx \mathcal{R}''$ .

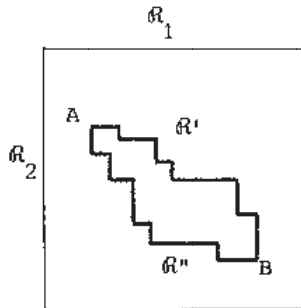

10.2.10.1. REMARK. By Theorem 10.1.2 hence also  $\mathcal{R}' \sim_s \mathcal{R}''$ . So each symbol in B traces back to a unique father symbol in A, regardless of the chosen path. (For  $\lambda\beta\eta$ -reduction diagrams this property is lost, as we will see in Ch.IV.)

10.3. The cardinality of equivalence classes  $[\mathcal{R}]_{\approx}$

In this subsection we will make a few remarks on  $[\mathcal{R}]_{\approx}$ :

- (1) in the  $\lambda\beta$ -calculus card.  $[\mathcal{R}]_{\approx}$  can be any number  $\leq \aleph_0$ , in  $\lambda I$ -calculus and  $\lambda^\tau$ -calculus (typed  $\lambda$ -calculus) any  $n < \aleph_0$ , but not  $\aleph_0$ .
- (2) we will give a condition for an  $\mathcal{R}$  to have card.  $[\mathcal{R}]_{\approx} = \aleph_0$ , and show

that this property of  $\mathcal{R}$  is not decidable.

10.3.1. EXAMPLES.

Notation:  $MI^{\sim n} := MII \dots I$  ( $n$  times  $I$ );  $KI$  is short for  $\lambda x.I$ .

$\Omega \equiv \omega\omega$ ;  $\omega \equiv \lambda x.xx$ .

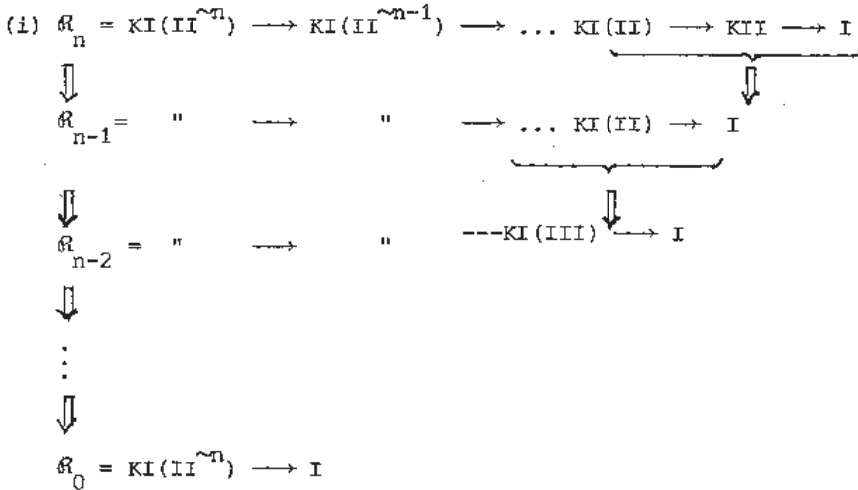

This example shows that  $\forall n \in \mathbb{N} \exists \mathcal{R} \text{ card } [\mathcal{R}]_{\approx} = n + 1$ .

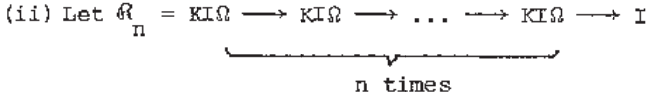

Then  $([\mathcal{R}_0]_{\approx}, \Rightarrow)$  is an infinite ascending chain:

$$\mathcal{R}_0 \Leftarrow \mathcal{R}_1 \Leftarrow \mathcal{R}_2 \Leftarrow \dots$$

(iii) The next example shows that also in  $\lambda I$ -calculus  $\text{card } [\mathcal{R}]_{\approx}$  can be any finite number  $> 0$ :

$$\text{Let } \mathcal{R}_n = II^{\sim n}(II) \longrightarrow II^{\sim n}I \ (\equiv II^{\sim n+1}) \longrightarrow \dots \longrightarrow I.$$

Then  $\text{card } [\mathcal{R}_n]_{\approx} = n + 2$ .

10.3.2. PROPOSITION. *There is no infinitely upwardly branching point in  $([\mathcal{R}]_{\approx}, \Rightarrow)$ , as in the figure:*

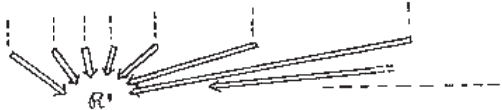

PROOF. Let us distinguish two kinds of  $\Rightarrow$ -steps:

- (a) those in which the "contractum" (or permutation) of the a.s. pair consists of at least two  $\longrightarrow$ -steps:

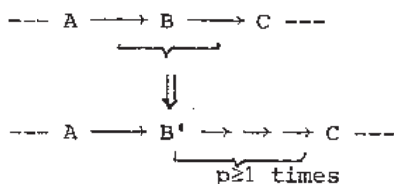

(b) those in which the contractum is just one  $\longrightarrow$ -step.

They can only be of the form

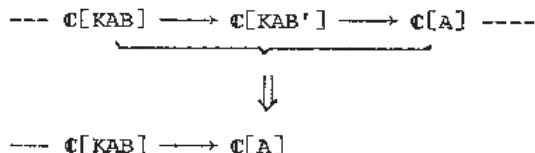

where  $\mathbb{C}[ ]$  is some context,  $KA := \lambda x.A$  ( $x \notin \text{FV}(A)$ ), and  $B \longrightarrow B'$ .

Now consider an  $\mathcal{R}'$  as in the above figure. Only finitely many subreductions of  $\mathcal{R}'$  can be the contractum of an a.s. pair. ( $\mathcal{R}''$  is subreduction of

$\mathcal{R}' \stackrel{\text{def.}}{\iff} \exists \mathcal{R}_1, \mathcal{R}_2 \mathcal{R}_1 * \mathcal{R}'' * \mathcal{R}_2 = \mathcal{R}'$ .)

In case (a) the original a.s. pair is completely determined by the contractum.

In case (b) there are just as many original a.s. pairs as  $B$  has redexes. Hence  $\mathcal{R}'$  can be reached by one  $\iff$ -step from at most finitely many  $\mathcal{R}''$ .  $\square$

10.3.3. DEFINITION. (i) Let  $M \in \text{Ter}(\lambda)$ . Then  $\infty(M)$  will mean:  $M$  is not SN (strongly normalizing), i.e.  $M$  has an infinite reduction. (Par abus de langage: ' $M$  is infinite'.)

(ii) If  $\mathcal{R}$  is a finite reduction,  $\mathcal{R}_s$  will denote the unique standard reduction  $\approx \mathcal{R}$ .

(iii)  $[\mathcal{R}]^\uparrow := \{\mathcal{R}'/\mathcal{R}' \iff \mathcal{R}\}$

(iv) A step  $\mathbb{C}[KAB] \longrightarrow \mathbb{C}[A]$  is called *erasing*. Here  $KA := (\lambda x.A)$  where  $x \notin \text{FV}(A)$ . The term  $B$  is called the *argument* of the redex  $KAB$ .

10.3.3.1. PROPOSITION. *The property  $\infty$  of  $\lambda$ -terms is undecidable.*

PROOF. Suppose  $\infty$  were decidable Then so was the property " $M$  is SN", in particular for  $\lambda I$ -terms  $M$ . Hence for  $\lambda I$ -terms  $M$ , the property " $M$  has a normal form" would be decidable; but is a well-known fact that this is not

the case. (See e.g. BARENDREGT [80].)  $\square$

10.3.4. DEFINITION. Let  $\mathcal{Q} \in \text{Ter}(\lambda)$ . The labeling  $I$  is called *strongly adequate* for  $\mathcal{Q}$ , iff  $I$  is adequate for every reduction  $\mathcal{Q} \longrightarrow \dots \longrightarrow \mathcal{Q}'$  (see Def. 10.2.4).

10.3.4.1. PROPOSITION. Let  $\mathcal{Q} \in \text{Ter}(\lambda)$ . Then:  $\mathcal{Q}$  is strongly normalizing  $\iff \mathcal{Q}$  has a strongly adequate labeling.

PROOF. ( $\Leftarrow$ ) Follows by SN for labeled reduction (Theorem 8.14) .

( $\Rightarrow$ ) Suppose  $\mathcal{Q} \in \text{SN}$ . Then, by König's Lemma, there are only finitely many reductions  $\mathcal{R}_j = \mathcal{Q} \longrightarrow \dots \longrightarrow \mathcal{Q}'$  ( $j = 1, \dots, n$ ). Let  $I_j$  be a labeling of  $\mathcal{Q}$  which is adequate for  $\mathcal{R}_j$  (by Proposition 10.2.4.1,  $I_j$  exists). Then take  $I = \max_{j=1, \dots, n} I_j$  in the obvious sense. Now  $I$  is strongly adequate for  $\mathcal{Q}$ .  $\square$

10.3.5. DEFINITION. Let  $\mathcal{R}^I = M^I \longrightarrow \dots \longrightarrow N^J$  be a labeled reduction. Then  $\mathcal{R}^I$  is called *special* iff

- (i)  $\mathcal{R}$  erases only strongly normalizing arguments (i.e. if  $\mathcal{R}$  contains a step  $\dots \text{KAB} \dots \longrightarrow \dots \text{A} \dots$ , then  $B \in \text{SN}$ ).
- (ii) Whenever  $\mathcal{R}$  contains an erasing step as in (i) and  $B \in \text{SN}$ , then the induced labeling of  $B$  is strongly adequate for  $B$ .

10.3.5.1. PROPOSITION. If  $\mathcal{R} = M \longrightarrow \dots \longrightarrow N$  erases only strongly normalizing arguments, then  $\mathcal{R}$  can be extended to a special labeled reduction  $\mathcal{R}^I = M^I \longrightarrow \dots \longrightarrow N^J$ .

PROOF. Routine.  $\square$

10.3.6. LEMMA. If  $\mathcal{R}_2 \rightleftharpoons \mathcal{R}_1$  and  $\mathcal{R}_1^I$  is special, then  $\mathcal{R}_2^I$  is special.

PROOF. Suppose  $\mathcal{R}_2 \rightleftharpoons \mathcal{R}_1$  and  $\mathcal{R}_1^I$  is special. Corresponding to (i), (ii) in Def. 10.3.5 we have

(i) to show that  $\mathcal{R}_2$  does not erase infinite arguments. Suppose  $\mathcal{R}_2$  does erase an infinite argument:

$$\mathcal{R}_2 = \mathcal{R} * \mathbb{C}[\text{KAB}] \longrightarrow \mathbb{C}[\text{A}] * \mathcal{R}', \text{ where } \infty(B).$$

Now there are three cases.

CASE 1. The displayed erasing step is not a member of the a.s. pair of steps, which is 'permuted' in  $\mathcal{R}_2 \rightleftharpoons \mathcal{R}_1$ . Then  $\mathcal{R}_1$  contains the same erasing

step, and  $\mathcal{R}_1$  erases an infinite argument; contradicting the assumption that  $\mathcal{R}_1^I$  is special.

CASE 2. The displayed erasing step is the left step of the permuted a.s. pair of steps. There are three subcases.

Case 2.1. Then

$$\mathcal{R}_2 = \dots \mathcal{C}'[(\lambda x. \text{--}KA(x)B(x)\text{--})D] \xrightarrow{K} \mathcal{C}'[(\lambda x. \text{--}A(x)\text{--})D] \\ \xrightarrow{\lambda x} \mathcal{C}'[\text{--}A(D)\text{--}] \longrightarrow \dots \text{ and}$$

$$\mathcal{R}_1 = \dots \xrightarrow{\lambda x} \mathcal{C}'[\text{--}KA(D)B(D)\text{--}] \xrightarrow{K} \mathcal{C}'[\text{--}A(D)\text{--}] \longrightarrow \dots \text{ and now } \mathcal{R}_1 \text{ erases } \\ B(D) \text{ which is still infinite.}$$

Case 2.2.

$$\mathcal{R}_2 = \dots \longrightarrow \mathcal{C}'[(\lambda x. P(x))(\text{--}KAB\text{--})] \xrightarrow{K} \mathcal{C}'[(\lambda x. P(x))(\text{--}A\text{--})] \\ \xrightarrow{\lambda x} \mathcal{C}'[P(\text{--}A\text{--})] \longrightarrow \dots \text{ and}$$

$$\mathcal{R}_1 = \dots \longrightarrow \dots \xrightarrow{\lambda x} \mathcal{C}'[P(\text{--}KAB\text{--})] \xrightarrow{K} \underbrace{\xrightarrow{K} \xrightarrow{K}}_{p \geq 0 \text{ times}}$$

$$\mathcal{C}'[P(\text{--}A\text{--})] \longrightarrow \dots$$

Here  $p \geq 0$  is the multiplicity of the occurrence of  $x$  in  $P(x)$ . If  $p \geq 1$ , then  $\mathcal{R}_1$  erases the infinite term  $B$ ; and if  $p = 0$ , then  $\mathcal{R}_1$  erases the infinite argument  $(\text{--}KAB\text{--})$  in the step  $\xrightarrow{\lambda x}$ .

Case 2.3.  $KAB$  is disjoint from the  $\lambda x$ -redex. Then  $\mathcal{R}_1$  erases  $B$ , trivial.

CASE 3. The displayed erasing step  $\mathcal{C}[KAB] \xrightarrow{K} \mathcal{C}[A]$  is the right step of the permuted a.s. pair. Let the redex contracted in the left step of the a.s. pair, begin with  $\lambda x$ . Again there are three subcases. Let  $R'$  be the contractum of the  $\lambda x$ -redex.

Case 3.1.  $R' \subseteq A$ : then  $\mathcal{R}_1$  erases  $B$

Case 3.2.  $R' \subseteq B$ . Then:

$$\mathcal{R}_2 = \dots \longrightarrow \mathcal{C}[KA(\text{--}(\lambda x. P(x))Q\text{--})] \xrightarrow{\lambda x} \mathcal{C}[KA(\text{--}P(Q)\text{--})] \xrightarrow{K} \mathcal{C}[A] \longrightarrow \dots$$

$$\text{and } \mathcal{R}_1 = \dots \longrightarrow \mathcal{C}[KA(\text{--}(\lambda x. P(x))Q\text{--})] \xrightarrow{K} \mathcal{C}[A] \longrightarrow \dots$$

Now since  $B \equiv \text{--}P(Q)\text{--}$  is infinite,  $\text{--}(\lambda x. P(x))Q\text{--}$  is also infinite. So also  $\mathcal{R}_1$  erases an infinite argument.

Case 3.3. Similar to case 2.3.

So in all cases 1,2,3 the assumption that  $\mathcal{R}_1^I$  is special is contradicted. This proves (i).



(ii) To show: (1)  $I$  is adequate for  $\mathcal{R}_2$ , and (2) if  $B_1, \dots, B_m$  are the arguments erased by  $\mathcal{R}_2$  (so by (i)  $B_1, \dots, B_m \in SN$ ) and  $I_1, \dots, I_m$  are their induced labelings, then  $I_1, \dots, I_m$  are strongly adequate for  $B_1, \dots, B_m$ .

The proof of (1) is easy. (Cf. the proof of Theorem 10.2.5 in which the converse was proved: if  $\mathcal{R}_2 \Rightarrow \mathcal{R}_1$  and  $I$  is adequate for  $\mathcal{R}_2$ , then  $I$  is adequate for  $\mathcal{R}_1$ . As in that proof, it is sufficient to consider the case that  $\mathcal{R}_2$  is an a.s. pair. See the figure in the proof of Theorem 10.2.5.)

To prove (2), we distinguish two cases.

Case (a). The step  $\mathcal{R}_2 \Rightarrow \mathcal{R}_1$  is of type (a), as in the proof of Proposition 10.3.2. This is the easy case, as an inspection will show.

Case (b). The step  $\mathcal{R}_2 \Rightarrow \mathcal{R}_1$  is of type (b). I.e., the "contractum" of the a.s. pair consists of just one step:

$$\begin{array}{c} \mathcal{R}_2^I = \dots \longrightarrow \mathfrak{C}[KAB_i^{I'}] \xrightarrow{(*)} \mathfrak{C}[KAB_i^{I''}] \xrightarrow{(**)} \mathfrak{C}[A] \longrightarrow \dots \\ \Downarrow \\ \mathcal{R}_1^I = \dots \longrightarrow \mathfrak{C}[KAB_i^{I'}] \longrightarrow \mathfrak{C}[A] \longrightarrow \dots \end{array}$$

We have only to consider the steps (\*), (\*\*) in  $\mathcal{R}_2^I$ , since the other steps of  $\mathcal{R}_2^I$  coincide with steps of  $\mathcal{R}_1^I$ .

The assumption is that the induced labeling  $I'$  of  $B_i$  (in  $\mathcal{R}_1^I$ ) is strongly adequate for  $B_i$ . Now in the step (\*) which reduces  $B_i$  to  $B_i^{I'}$ , something can be erased; say this is  $C^J$ . Then  $C$  is SN and  $J$  is strongly adequate for  $C$ , since  $C^J \subseteq B_i^{I'}$  in  $\mathcal{R}_1^I$ . Also it is clear that in the step (\*\*)  $I''$  is strongly adequate for  $B_i^{I'}$ , since  $B_i^{I''}$  is a reduct of  $B_i^{I'}$ . This proves (ii).  $\square$

10.3.7. THEOREM. Let  $\mathcal{R}$  be a finite reduction. Then:  $[\mathcal{R}]^\uparrow$  is infinite  $\Leftrightarrow \mathcal{R}$  erases an infinite argument.

PROOF. ( $\Leftarrow$ ) Suppose  $\mathcal{R}$  erases an infinite argument:

$$\mathcal{R} = \dots \longrightarrow \mathfrak{C}[KAB] \longrightarrow \mathfrak{C}[A] \longrightarrow \dots \text{ where } \infty(B).$$

Let  $B \equiv B_0 \rightarrow B_1 \rightarrow B_2 \rightarrow \dots$  be an infinite reduction of  $B$ .

Define for all  $n \in \mathbb{N}$ :

$$\mathcal{R}_n = \dots \longrightarrow \mathfrak{C}[KAB] \longrightarrow \mathfrak{C}[KAB_1] \longrightarrow \dots \longrightarrow \mathfrak{C}[KAB_n] \longrightarrow \mathfrak{C}[A] \longrightarrow \dots$$

Then obviously  $\mathcal{R} = \mathcal{R}_0 \Leftarrow \mathcal{R}_1 \Leftarrow \mathcal{R}_2 \Leftarrow \dots$ .

Hence  $[\mathcal{R}]^\uparrow$  is infinite.

( $\Rightarrow$ ) Let us first remark that by Proposition 10.3.2 and König's Lemma:

$[\mathcal{R}]^{\uparrow}$  is infinite  $\Leftrightarrow$  there is an infinite 'ascending' sequence  
 $\mathcal{R} \Leftarrow \mathcal{R}' \Leftarrow \mathcal{R}'' \Leftarrow \dots$

Now suppose that the implication which is to be proved, does not hold.  
 So suppose that  $[\mathcal{R}]^{\uparrow}$  is infinite, hence that there is a sequence  
 $\mathcal{R} \Leftarrow \mathcal{R}' \Leftarrow \dots$ , but that  $\mathcal{R}$  nevertheless erases only strongly normalizing  
 arguments.

Then by Proposition 10.3.5.1,  $\mathcal{R}$  can be extended to a special labeled  
 reduction  $\mathcal{R}^I$ . By Lemma 10.3.6 we have now an infinite sequence of special  
 labeled reductions  $\mathcal{R}^I \Leftarrow \mathcal{R}'^I \Leftarrow \mathcal{R}''^I \Leftarrow \dots$

But that is impossible, since there are only finitely many labeled reduc-  
 tions of  $M^I$  (the first term of  $\mathcal{R}^I, \mathcal{R}'^I, \dots$ ) and since  $\Leftarrow$  is acyclic. (This  
 is the same argument as at the end of the proof of Theorem 10.2.5.(i),  
 but now for an 'ascending'  $\Leftarrow$ -sequence, instead of a descending one.)  $\square$

10.3.8. COROLLARY. Let  $\mathcal{R}$  be a finite reduction.

- (i)  $[\mathcal{R}]_{\approx}$  is infinite  $\Leftrightarrow \mathcal{R}_S$  erases an infinite argument.
- (ii) In  $\lambda I$ -calculus  $[\mathcal{R}]_{\approx}$  is finite, for every  $\mathcal{R}$ .  
 Similarly in  $\lambda^T$ -calculus (typed  $\lambda$ -calculus).
- (iii) The property ' $[\mathcal{R}]_{\approx}$  is infinite' is not decidable.

PROOF. (i)  $[\mathcal{R}]_{\approx} = [\mathcal{R}_S]^{\uparrow}$ , by Corollary 10.2.8.(i), (ii). Hence the result  
 follows from the preceding theorem.

(ii) At once by the preceding theorem, since in  $\lambda I$ -calculus there is no  
 erasing and in  $\lambda^T$ -calculus there are no 'infinite' terms (i.e.  $\lambda^T \models SN$ ,  
 Theorem 8.14).

(iii) By (i) and Proposition 10.3.3.1.  $\square$

10.3.9. EXAMPLE. (i) Let  $\mathcal{R}$  be  $(\lambda x.KI(xx))\omega \longrightarrow (\lambda x.I)\omega \longrightarrow I$ , where  
 $\omega \equiv \lambda x.xx$ .

Then  $([\mathcal{R}]_{\approx}, \Rightarrow)$  is as in the figure:

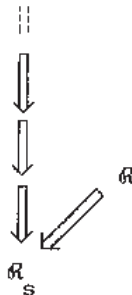

Note that in  $\mathcal{R}$  no infinite subterm is erased, contrary to  $\mathcal{R}_s$ .

(ii). Let  $\mathcal{R}$  be a reduction from  $M \equiv [\lambda x.KI(I\omega x)]\omega$  to  $I$ .

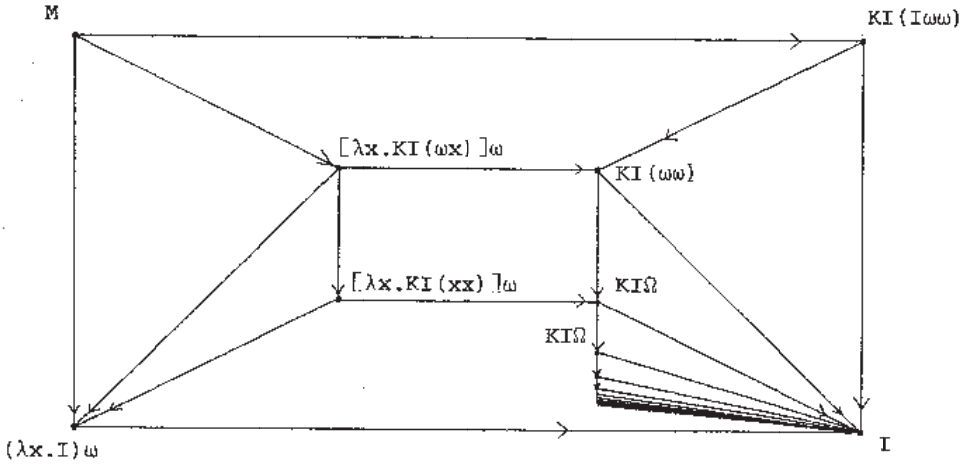

Then  $([\mathcal{R}]_s, \Rightarrow)$  can be pictured as follows (at each node there is a reduction which is indicated as a tuple in an obvious shorthand.)

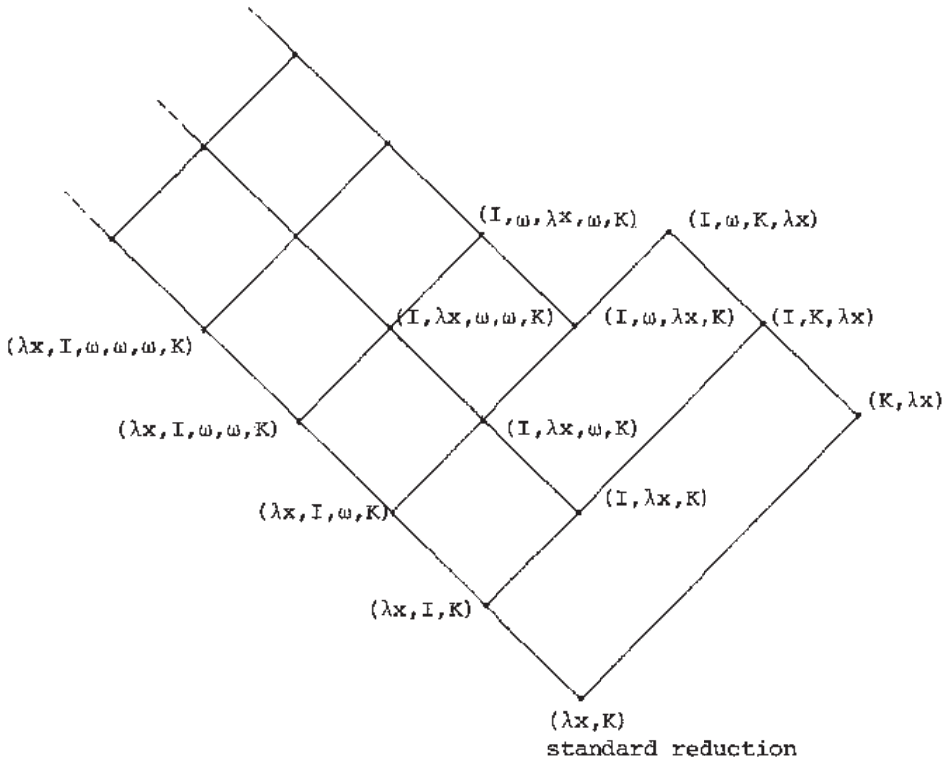

## 11. NORMALIZATION

11.0. DEFINITION. (i) Let  $M \in \lambda P$  (a definable extension of  $\lambda$ -calculus), and  $R, R'$  be  $\beta$ - or  $P$ -redexes in  $M$ . Then:  $R$  is to the left of  $R'$ , notation  $R < R'$ , if the head-symbol of  $R$  ( $\lambda$  or  $P$ ) is to the left of that of  $R'$ .

(ii)  $R \subseteq M$  is the *leftmost* redex in  $M$  iff  $R < R'$  for every redex  $R'$  in  $M$ .

The leftmost redex is also called the *normal* redex, for a reason that will be clear soon.

(iii) A reduction  $\mathcal{R}$  (finite or infinite) is *normal* (or *leftmost*) if it proceeds by contracting in each step the leftmost redex. A leftmost step will be denoted as  $\xrightarrow{\text{lm}}$ .

(iv) A reduction  $\mathcal{R} = M_0 \longrightarrow M_1 \longrightarrow \dots$  is *quasi-normal* if it is finite, or else if

$$\forall i \exists j > i \quad M_j \xrightarrow{\text{lm}} M_{j+1}.$$

Quasi-normal reductions are also called *eventually leftmost* reductions.

(v) A reduction is *maximal* if it ends in a normal form, or is infinite.

(vi) A class  $C$  of maximal reductions is said to be *normalizing* if for all  $\mathcal{R} \in C$ :

$\mathcal{R}(0)$  has a normal form  $\Rightarrow \mathcal{R}$  ends in this normal form. Here  $\mathcal{R}(0)$  is the first term of  $\mathcal{R}$ ; see the following notational convention.

('Par abus de langage' we will henceforth just say: 'such-and-such reductions are normalizing' instead of 'the class of maximal s.a.s. reductions is normalizing'.)

11.0.1. REMARK. The terminology 'normalizing', 'normal redex' and 'Normalization Theorem' is historical (from CURRY, FEYS [58]). One should not confuse the property asserted by the Normalization Theorem 11.2 with the properties WN and SN (Weak and Strong Normalization), which do not hold for  $\lambda\beta$ .

11.1. NOTATION. Let  $\mathcal{R} = M_0 \longrightarrow M_1 \longrightarrow \dots$

(i) Then write  $\mathcal{R}(n) \equiv M_n$  for all  $n$  (for which  $M_n$  is defined).

(ii)  $(\mathcal{R})_n = M_n \longrightarrow M_{n+1} \longrightarrow \dots$

$${}_n(\mathcal{R}) = M_0 \longrightarrow \dots \longrightarrow M_n.$$

So  $\mathcal{R} = {}_n(\mathcal{R}) * (\mathcal{R})_n = \mathcal{R}(0) \longrightarrow \mathcal{R}(1) \longrightarrow \dots$

## 11.2. NORMALIZATION THEOREM

*Normal reductions are normalizing.*

PROOF. Let  $\mathcal{R} = M \twoheadrightarrow N$  where  $N$  is in normal form. By the Standardization Theorem (9.7), there is a standard reduction  $\mathcal{R}_s = M \twoheadrightarrow N$ . Moreover,  $\mathcal{R}_s$  is a normal reduction. For suppose not, then  $\mathcal{R}_s$  'by-passes' in some step the leftmost redex. By the usual arguments, one proves easily that this by-passed redex has a residual in  $N$ . But  $N$  is a normal form. Contradiction.  $\square$

Next we will prove that quasi-normal reductions are normalizing too. For an alternative proof see BARENDREGT [80]; the reason for including an alternative proof here is that it lends itself to a generalization to  $\lambda\beta\eta$ -calculus (Ch.IV).

10.3. PROPOSITION. Let  $\mathcal{R}_{qn} = M_0 \longrightarrow M_1 \longrightarrow \dots$  be a quasi-normal (qn) reduction. Then:

- (i)  $k(\mathcal{R}_{qn}) = M_k \longrightarrow M_{k+1} \longrightarrow \dots$  is a qn reduction,
- (ii) if  $\mathcal{R} = N_0 \longrightarrow \dots \longrightarrow M_0$  is an arbitrary reduction, also  $\mathcal{R} * \mathcal{R}_{qn} = N_0 \longrightarrow \dots \longrightarrow M_0 \longrightarrow M_1 \longrightarrow \dots$  is qn.

PROOF. Trivial from the definitions.  $\square$

11.4. DEFINITION. Let  $\mathcal{R} = M_0 \longrightarrow M_1 \longrightarrow \dots$  be a finite or infinite reduction and  $R \subseteq M_n$  some redex in  $\mathcal{R}$ .

$R$  is called *secured* in  $\mathcal{R}$  iff eventually there are no residuals of  $R$  left (i.e. some  $M_{n+k}$  contains no residuals of  $R$ ).

11.5. LEMMA. Let  $\mathcal{R}_{qn} = M_0 \longrightarrow \dots$  be a qn-reduction, and let  $R \subseteq M_0$  be the leftmost redex.

Then  $R$  is secured in  $\mathcal{R}_{qn}$ .

PROOF. Almost trivial: the first leftmost step in  $\mathcal{R}_{qn}$  contracts the unique residual of  $R$ .  $\square$

11.6. COROLLARY (Quasi-normalization Theorem).

*Quasi-normal reductions are normalizing.*

PROOF. Suppose  $M$  has a normal form  $N$ . Let  $\mathcal{R}_n = M \xrightarrow{1n} N$  be the normal reduction to  $N$ .

Now suppose that an infinite quasi-normal  $\mathcal{R}_{qn}$ , starting with  $M$ , exists.

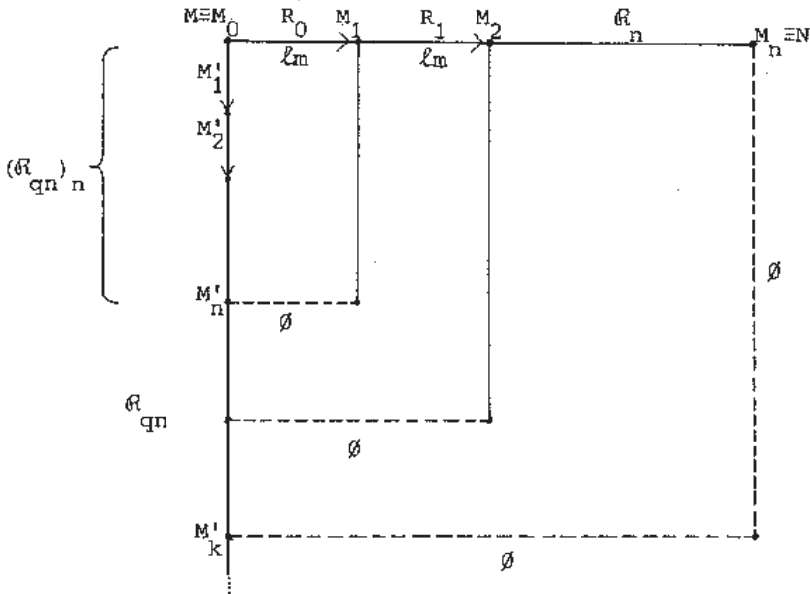

By the preceding lemma, and the Parallel Moves Lemma (6.12) for some  $n$  the projection  $\{R_0\}/(R_{qn})_n = \emptyset$ .

By Proposition 11.3,  $[(R_{qn})_n/\{R_0\}] * {}_n(R_{qn})$  is again quasi-normal, hence  $R_1 \subseteq M_1$  is secured in it.

Repeating this argument we get a  $k$  such that

$$\mathcal{R}_n / (R_{qn})_k = \emptyset,$$

and because  $M_n \equiv N$  is in normal form, also

$$(R_{qn})_k / \mathcal{R}_n = \emptyset.$$

Hence  $M'_k \equiv M_n \equiv N$ , i.e.  $\mathcal{R}_{qn}$  ends in the normal form.  $\square$

## 12. COFINAL REDUCTIONS

The reduction graph  $\mathcal{G}(M)$  of a term  $M$ , that is the structure  $\langle \{N/M \twoheadrightarrow N\}, \twoheadrightarrow \rangle$ , can be quite complicated and sometimes it is very useful to know a cofinal reduction path  $\mathcal{R}_c = M \twoheadrightarrow M' \twoheadrightarrow M'' \twoheadrightarrow \dots$  in

$G(M)$ , in order to reduce properties of the whole graph  $G(M)$  to properties of  $\mathcal{R}_c$ .

12.1. DEFINITION.  $\mathcal{R}_c$  is a cofinal reduction path in  $G(M)$  iff  $\forall N \in G(M) \exists n \in \mathbb{N} N \rightarrow \mathcal{R}_c(n)$ .

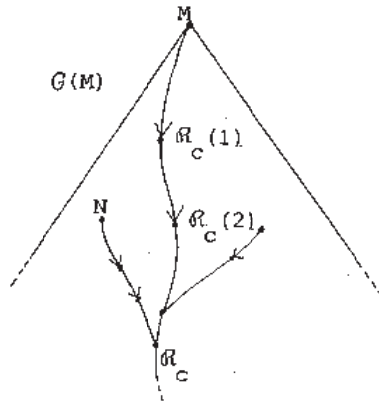

In BARENDREGT e.a. [77] some typical applications of cofinal reductions can be found. In BARENDREGT e.a. [76] (Ch.II) it is proved that a certain kind of reduction called *Knuth-Gross reduction* is cofinal (for  $\lambda\beta$  as well as  $\lambda\beta\eta$ ). For technical applications, sometimes one needs a refinement of this result. Such a refinement will be proved now. In Chapter IV the same is done for  $\lambda\beta\eta$ -calculus.

12.2. DEFINITION.  $\mathcal{R}$  is called *secured* iff every redex  $R$  in  $\mathcal{R}$  is secured in  $\mathcal{R}$ . (I.e.: iff  $\forall n \forall \text{redex } R \subseteq \mathcal{R}(n) R$  is secured in  $(\mathcal{R})_n$ .)  
(See also Definition 11.4.)

REMARK. Obviously, for all  $n$ :  $\mathcal{R}$  is secured  $\Leftrightarrow (\mathcal{R})_n$  is secured.

The next theorem is obtained independently in MICALI [78], where as an application a 'space saving' reduction strategy is given. When writing this section, we learned that the theorem occurs moreover in O'DONNELL [77], where it is proved in an abstract setting; see Theorem 8 and 8'. Our 'secured' reductions are called there 'complete'.

12.3. THEOREM. Let  $\mathcal{R}$  be a reduction path in  $G(M)$ . Then:  $\mathcal{R}$  is secured  $\Rightarrow \mathcal{R}$  is cofinal.

PROOF. Let the secured reduction  $\mathcal{R} = M \longrightarrow \dots$  and an arbitrary reduction  $\mathcal{R}' = M \longrightarrow \dots \longrightarrow N$  be given. We have to prove that  $N \twoheadrightarrow \mathcal{R}(k)$  for some  $k$ . Construct  $\mathcal{D}(\mathcal{R}', \mathcal{R})$  (see figure). Now for some  $i_0$ ,  $\mathcal{R}(i_0)$  does not contain a residual of  $R_0$ . Hence by PM(6.12):  $\{R_0\}/i_0(\mathcal{R}) = \emptyset$ .

By the remark after 12.2 also  $(i_0(\mathcal{R})/\{R_0\}) * (\mathcal{R})_{i_0}$  is secured.

Hence for some  $i_1$ :  $(\{R_0\} * \{R_1\})/i_1(\mathcal{R}) = \emptyset$ . So for some  $k$ ,  $\mathcal{R}'/k(\mathcal{R}) = \emptyset$ ; i.e.  $N \twoheadrightarrow \mathcal{R}(k)$ .  $\square$

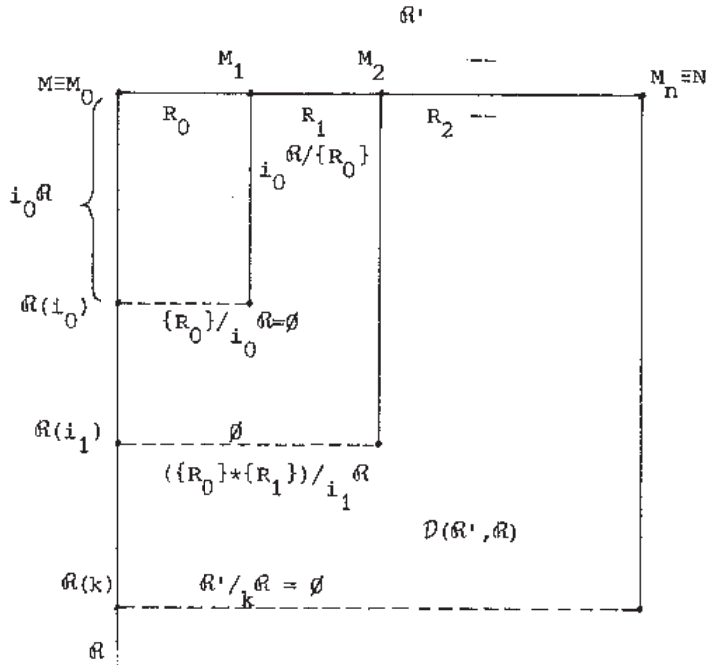

12.3.1. REMARK. The converse implication does not hold; counterexample: Let  $M \equiv \lambda z.z\Omega\Omega$  where  $\Omega \equiv (\lambda x.xx)(\lambda x.xx)$ , and consider  $\mathcal{R} = M \longrightarrow M \longrightarrow M \longrightarrow \dots$  where every time the right occurrence of  $\Omega$  is contracted.

12.4. DEFINITION. Let  $M$  be a  $\lambda P$ -term. Consider the set of all  $\beta$ -redexes and  $P$ -redexes in  $M$ , and let  $N$  be the result of a complete development of all those redexes. Then  $N$  is unique (by FD, Theorem 4.1.11 and Prop.6.3).

NOTATION:  $M \xrightarrow{KG} N$ . Here  $\xrightarrow{KG}$  stands for 'Knuth-Gross'-reduction. A Knuth-Gross reduction is a sequence of KG-'steps'.

Knuth-Gross reduction is called the 'full computation rule' for Recursive Program Schemes (see MANNA [74]).



12.5. COROLLARY. *Knuth-Gross reductions (in  $\lambda P$ ) are cofinal.*

PROOF. After each complete development of the total set of redexes of  $M$ , no residuals are left of the redexes in  $M$ . And so on. Hence the KG-reduction is secured.  $\square$

12.6. DEFINITION.  $\mathcal{R}$  is a quasi-KG-reduction if it is finite or contains infinitely many KG-reduction 'steps'.

12.7. COROLLARY. *Quasi-KG-reductions (in  $\lambda P$ ) are cofinal.*

PROOF. Let  $M_0 \xrightarrow{R_0} M_1 \longrightarrow \dots \longrightarrow M_n$  be a finite reduction, and let  $\mathcal{R}$  be a quasi-KG-reduction. Let  $A \xrightarrow{KG} B$  the first KG-step in  $\mathcal{R}$ . (See figure.)

Now by PM(6.12)  $A \twoheadrightarrow C$  is a development of the residuals of  $R_0$ , and hence (since  $\xrightarrow{KG}$  is in fact a complete development of all the redexes in  $B$ )  $B \twoheadrightarrow D$  is the empty reduction. Repeating this argument, we find that indeed  $M_n \twoheadrightarrow \mathcal{R}(m)$  for some  $m$ .  $\square$

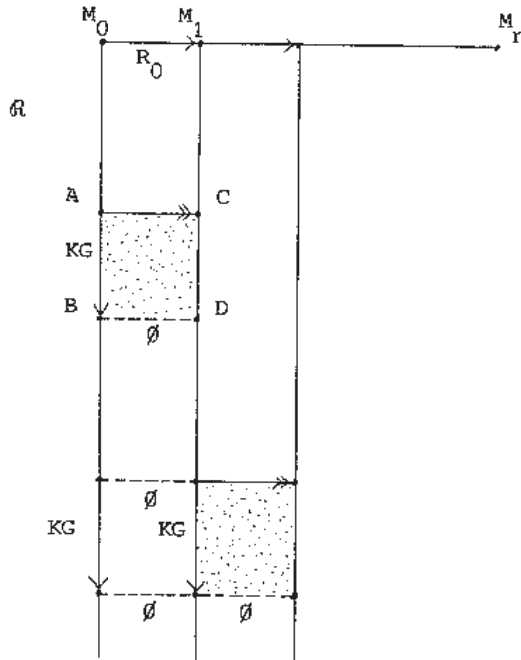

## CHAPTER II

## REGULAR COMBINATORY REDUCTION SYSTEMS

In this chapter we introduce a generalization of the reduction systems in Chapter I (subsystems of definable extensions of  $\lambda\beta$ -calculus, such as  $\lambda I$ , CL, Recursive Program Schemes), which we will call 'Combinatory Reduction Systems' (CRS). A CRS is in fact a TRS (Term Rewriting System) possibly with *bound variables*. So we will consider variable-binding mechanisms other than the usual one in  $\lambda$ -calculus; see Remarks 1.17, 1.18, 1.20 below for a general discussion and a comparison with some notions of 'reduction system' which occur in the literature.

We will consider in the present chapter only CRS's with two well-known constraints: the reduction rules must be '*left-linear*' and the '*non-ambiguity*' property must be satisfied. For reasons of economy we use the abbreviation

*regular = left-linear & non-ambiguous.*

(In Chapter III we will consider some non-left-linear CRS's.)

In Section 1 we introduce the concept of a regular CRS. Section 2 contains the definitions of 'descendant' for regular CRS's (via labels, as in I.3), and of 'development'. In Section 3 a proof of the Church-Rosser theorem for regular CRS's is given; this is done via an analysis of combinatory reductions into a 'term rewriting part' (as in CL) and a 'substitution part' (as in  $\lambda$ ). Some non-trivial technical propositions are required to prove even the simple property WCR for regular CRS's (Lemma 3.10). In this stage the Finite Developments theorem and its corollaries  $CR^+$ , PM (analogous to resp. Thm. I.4.1.11 and its corollaries I.6.9 and I.6.12) are not yet proved; to obtain FD, which is a Strong Normalization result, we introduce 'reductions with memory' and generalize a method of R. Nederpelt to the class of regular CRS's. Using this method, which seems interesting for its

own sake, we obtain FD and hence  $CR^+$ , PM; now a large part of Chapter I generalizes at once to regular CRS's (e.g. Lévy-equivalence of reductions).

In Section 5 we investigate the property 'non-erasing' and state a generalization of Church's Theorem (I.7.5) for regular non-erasing CRS's.

In Section 6 we explore further conditions which ensure Strong Normalization for regular CRS's; as in Section 5, an application in Proof Theory is given. We prove here a generalization of Theorem I.8.14 ( $\lambda^{HW} \models SN$ , etc.). Furthermore, Lévy's method of labeling (I.3.9) is generalized to all regular CRS's, together with the corresponding SN result. This yields a tool to prove the Standardization and Normalization Theorem for a restricted class of regular CRS's (viz. the 'left-normal' ones).

## 1. COMBINATORY REDUCTION SYSTEMS

In this section we will define the concept of a *Combinatory Reduction System* (CRS). A CRS  $\Sigma$  will be a pair  $\langle \text{Ter}(\Sigma), \{\rho_i / i \in I\} \rangle$  where  $\text{Ter}(\Sigma)$  is the set of *terms* of  $\Sigma$  and where the  $\rho_i$  are *reduction relations* on  $\text{Ter}(\Sigma)$ .

So a CRS is a special kind of ARS, as in I.5. The reduction relations  $\rho_i$  are generated by *reduction rules*  $r_i$ ;  $\text{Red}(\Sigma) = \{r_i / i \in I\}$  is the set of reduction rules of  $\Sigma$ .  $\text{Ter}(\Sigma)$  is built inductively from the *alphabet* of  $\Sigma$ . In order to define the  $r_i$  ( $i \in I$ ), we will use *meta-variables* (written as  $Z$  plus sub- and superscripts) in a formal way; that is, they serve to define the set  $\text{Mter}(\Sigma)$  of *meta-terms*. There will be meta-variables of 'arity 0', as in the definition of, say, the reduction rules for CL:

$$S Z_1 Z_2 Z_3 \longrightarrow Z_1 Z_3 (Z_2 Z_3)$$

$$K Z_1 Z_2 \longrightarrow Z_1$$

but also of arity  $> 0$ , to allow a description of reduction rules involving substitution, as e.g. in the rules for  $m \geq 1$ :

$$\beta_m = (\lambda x_1 \dots x_m . Z_0(x_1, \dots, x_m)) Z_1 \dots Z_m \longrightarrow Z_0(Z_1, \dots, Z_m)$$

(see I.4.2.1). Here  $Z_0$  is  $m$ -air and the other meta-variables are 0-air.

Our universe of discourse in this and the next Chapter is the class of CRS's; this class will be closed under the formation of *substructures*, as defined for ARS's in Def. I.5.10. In fact that definition has to be

slightly extended, since in that case only one reduction relation is present. Therefore:

1.0. DEFINITION. Let  $\Sigma = \langle S, \{r_i / i \in I\} \rangle$  and  $\Sigma' = \langle S', \{r'_i / i \in I'\} \rangle$  be ARS's. Then  $\Sigma' \subseteq \Sigma$  ( $\Sigma'$  is a substructure of  $\Sigma$ ) iff

- (i)  $S' \subseteq S$  and  $I' \subseteq I$ ,
- (ii) for all  $i \in I'$ ,  $r'_i$  is the restriction of  $r_i$  to  $S'$ ,
- (iii)  $S'$  is closed under  $r_i$ , for all  $i \in I$ .

1.1. DEFINITION. The alphabet of a CRS consists of

- (i) a countably infinite set  $\text{Var} = \{x, y, z, \dots\}$  of variables,
- (ii) the improper symbols  $(, , ,), [, ]$
- (iii) some set  $Q = \{Q_i / i \in I\}$  of constants
- (iv) a set of metavariables  $\text{Mvar} = \{Z_i^k / i, k \in \mathbb{N}\}$ .

Here  $k$  is called the arity of  $Z_i^k$ .

(REMARK. As in Chapter I, the metavariables in, say, a rule as  $KZ_0Z_1 \rightarrow Z_0$  or  $(\lambda x.Z_0(x))Z_1 \rightarrow Z_0(Z_1)$  will range over the set of terms; but here we will treat the metavariables in a more formal way, using valuations.)

1.2. DEFINITION. The set  $\text{Ter}$  of terms of a CRS with the above alphabet is defined inductively by

- (i)  $Q \cup \text{Var} \subseteq \text{Ter}$
- (ii)  $x \in \text{Var}, A \in \text{Ter} \Rightarrow [x]A \in \text{Ter}$  (abstraction)
- (iii)  $A, B \in \text{Ter} \Rightarrow (AB) \in \text{Ter}$  (application)

provided  $A$  is not of the form  $[x]A'$ .

1.3. REMARK. (i) CRS's having an alphabet and terms as defined above but without the metavariables of positive arity, without 1.2(ii) and without the proviso in 1.2(iii), are known as *Term Rewriting Systems* (TRS's); see e.g. HUET [78]. These are CRS's 'without substitution', such as CL.

(ii) The proviso in Definition 1.2(iii) is not really necessary, but notationally pleasant; see Remark 1.9 below.

(iii) In  $[x]A$  the displayed occurrence of  $x$  is said to bind the free occurrences of  $x$  in  $A$ . The definition of the notions 'free and bound variable' is analogous to that in the case of  $\lambda$ -calculus (see I.1). There are the usual problems due to  $\alpha$ -conversion (renaming of bound variables, see I.1.6),

but as usual they can safely be ignored (here anyway).

We will adopt the convention that all the abstractors  $[x]$  in a term be different.

(iv) The usual notational convention of 'association to the left' (as in I.1.2) will be employed. Outer brackets will be omitted. We write an  $n$ -fold abstraction term  $[x_1][x_2] \dots [x_n]A$  as  $[x_1 x_2 \dots x_n]A$  or  $[\vec{x}]A$ . A term  $Q[\vec{x}]A$  for some constant  $Q \in Q$  will be written as  $Q\vec{x}.A$ .

1.4. EXAMPLE. (i) Let  $\Sigma$  be a CRS such that  $\lambda \in Q$ . Then  $(((\lambda[x](xx))\lambda) \in \text{Ter}(\Sigma)$ . Using the notational conventions above this term may be written  $(\lambda x.xx)\lambda$ . Another  $\Sigma$ -term:  $(\lambda x.xx)[yz](yyz)$ .

(In practice we won't need and will not consider such pathological " $\lambda$ -terms", but in this stage we want to be as liberal as possible in our term formation.)

(ii) Let  $\Sigma$  be a CRS such that  $\{\exists, \forall, \&, =\} \subseteq Q$ . Then  $\exists y. \forall x. \& (=xx) (=yy)$  is a  $\Sigma$ -term.

1.5. REMARK. ACZEL [78] employs a different notation, in which every term is denoted by an  $n$ -ary function ( $n \geq 0$ ):  $F(A_1, \dots, A_n)$  instead of our  $FA_1 \dots A_n$ . The two notations are practically equivalent; our notation yields more terms, viz. also  $F, FA_1, FA_2, \dots$  are subterms of  $FA_1 \dots A_n$ . (However, when  $\lambda$ -terms are present one can use  $\lambda x_1 \dots x_n. F(x_1, \dots, x_n)$  instead of  $F, \lambda x_2 \dots x_n. F(A_1, x_2, \dots, x_n)$  instead of  $FA_1$ , and so on.) We have preferred our notation to conform with the notation in Chapter I.

Instead of our set  $Q$  of constants, ACZEL [78] uses a set  $F = \{F_i / i \in I\}$  of forms, each form having an arity  $\langle k_1, \dots, k_n \rangle$ , an  $n$ -tuple of natural numbers ( $n \geq 0$ ). A form of arity  $\langle \rangle$  ( $n=0$ ) is called there a *constant*, a form of arity  $\langle 0, 0, \dots, 0 \rangle$  is called a *simple form*. Term formation in ACZEL [78] is as follows:

- (i)  $\text{Var} \subseteq \text{Ter}$
- (ii) if  $F \in F$  with arity  $\langle k_1, \dots, k_n \rangle$  and  $A_1, \dots, A_n \in \text{Ter}$ , then  $F([\vec{x}_1]A_1, \dots, [x_n]A_n) \in \text{Ter}$ , where  $[\vec{x}_i]$  ( $i = 1, \dots, n$ ) is a string of  $k_i$  variables.

So e.g. 'application'  $\cdot(-, -)$  is a simple form of arity  $\langle 0, 0 \rangle$ , and ' $\lambda$ -abstraction'  $\lambda([-])$  is a form of arity  $\langle 1 \rangle$ . The *recursor*  $R$  is a simple form of arity  $\langle 0, 0, 0 \rangle$ . An interesting non-simple form of arity  $\langle 1, 1, 0 \rangle$  is encountered when derivations in "Natural Deduction" are reduced to a normal

form; see Example 1.12.(v).

1.6. DEFINITION. (1) The set Mter of meta-terms over the alphabet as in Def.1.1 is defined inductively as follows:

(i), (ii), (iii) as in Def.1.2, replacing Ter by Mter

(iv)  $H_1, \dots, H_k \in \text{Mter} \Rightarrow Z_i^k(H_1, \dots, H_k) \in \text{Mter}$ , for all  $k, i \geq 0$ .

(2) A meta-term  $H$  is called *closed*, if it contains no free variables, i.e. if every  $x \in \text{Var}$  occurring in  $H$  is bound by an occurrence of  $[x]$ .

REMARK ad (1): So in particular 0-ary meta-variables are meta-terms. On the other hand,  $n+1$ -ary meta-variables are not in Mter. The purpose of the brackets in  $Z_i^k(H_1, \dots, H_k)$  will be clarified in 1.10, 1.11 below. Furthermore, note that  $\text{Ter} \subseteq \text{Mter}$ .

As in ACZEL [78], we will use  $H, H', H_1, \dots$  as "meta-meta-variables" ranging over Mter.

1.7. DEFINITION of formation trees corresponding to meta-terms.

Let  $H \in \text{Mter}$ . Then  $\tau(H)$ , the *formation tree* of  $H$ , is defined by induction on the formation of  $H$  as follows.

(i)  $\tau(x) = x, \quad \tau(Q_i) = Q_i$

(ii)  $\tau([x]H) = [x]$

$\begin{array}{c} \uparrow \\ \tau(H) \end{array}$

(iii)  $\tau(AB) =$

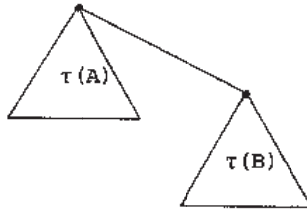

(iv)  $\tau(Z(H_1, \dots, H_k)) = Z(H_1, \dots, H_k) \quad (k \geq 0)$

1.8. EXAMPLE. (i) The terms in Example 1.4 have formation trees

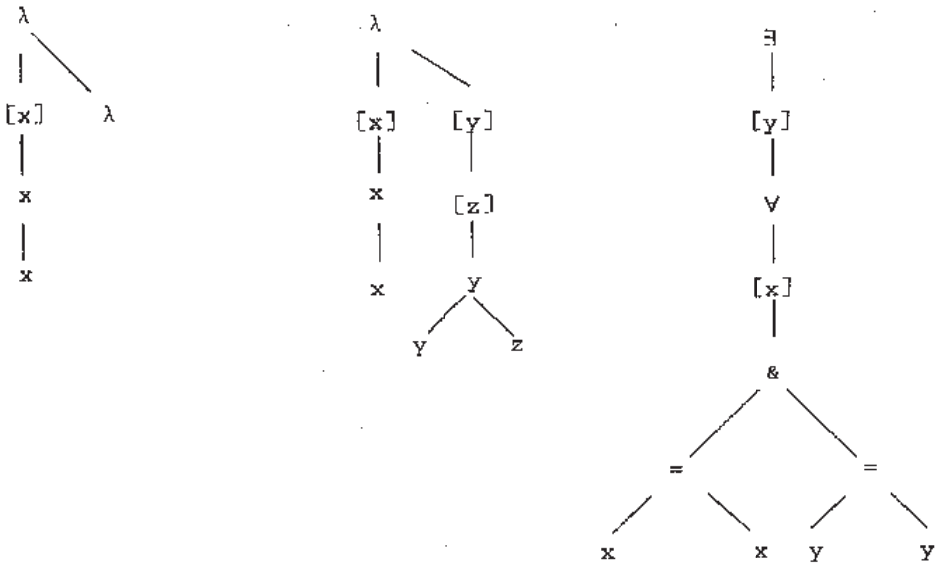

(ii) The meta-term  $(\lambda x.z_1^1(x))z_2^2(y,z_3^0)$  has the formation tree

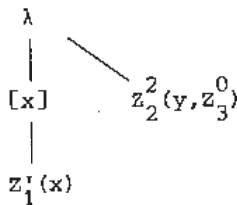

1.9. REMARK. Note that by the restriction in Def.1.2.(iii), an  $[x]$  has only one successor in  $\tau(H)$ . Without this restriction, we would have formation trees like

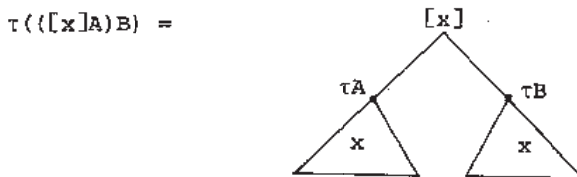

suggesting that the free occurrences of  $x$  in both  $\tau A$  and  $\tau B$  are bound by  $[x]$ , which is not intended since the scope of  $[x]$  in  $([x]A)B$  does not extend to  $B$ . So the restriction in Def.1.2.(iii) yields the pleasant property

that the scope of a variable  $x$  equals the whole subtree below that occurrence of  $x$  in the formation tree.

1.10. DEFINITION. (1) A valuation  $\rho$  is a map  $Mter \rightarrow Ter$  such that  $\rho(Z_i^k) = A(x_1, \dots, x_k)$ , i.e.  $\rho$  assigns to a  $k$ -ary metavariable a term plus a specification of  $k$  variables.

(2) The valuation  $\rho$  is extended to a map  $Mter \rightarrow Ter$ , also denoted by  $\rho$ , as follows:

- (i)  $\rho(x) = x, \quad \rho(Q_i) = Q_i$
- (ii)  $\rho([x]H) = [x]\rho(H)$
- (iii)  $\rho(H_1 H_2) = \rho(H_1)\rho(H_2)$
- (iv)  $\rho(Z_i^k(H_1, \dots, H_k)) = \rho(Z_i^k)(\rho H_1, \dots, \rho H_k)$

Here in (iv) it is meant that if  $\rho(Z_i^k) = A(x_1, \dots, x_k)$  then  $\rho(Z_i^k)(\rho H_1, \dots, \rho H_k) := A(\rho H_1, \dots, \rho H_k)$ , i.e. the result of the simultaneous substitution of  $\rho H_i$  for  $x_i$  ( $i = 1, \dots, k$ ) in  $A$ .

1.10.1. REMARK. Given a meta-term  $H$  and a valuation  $\rho$ , the term  $\rho H$  is obtained by performing a number of nested simultaneous substitutions.

Hence one can ask whether the order in which these substitutions are performed, affects the end result- and one may even ask if there is always an end result. That indeed every execution of the simultaneous substitutions terminates in a unique result, is a consequence of  $\underline{\lambda\beta}_m \models SN$  (Theorem I.4.2.5, stating that all developments are finite in  $\lambda\beta_m$ -calculus), and of  $\underline{\lambda\beta}_m \models WCR$  (the weak Church-Rosser property for underlined  $\lambda\beta_m$ -calculus, which is easy to check).

1.10.2. EXAMPLE. Let  $Z^2, Z^1, Z^0$  be resp. a binary, an unary, and a 0-ary metavariable. Let  $H = Z^2(Z^2(Z^0, Z^0), Z^1(Z^0))$  and let  $\rho$  be a valuation such that:

$$\begin{aligned} \rho(Z^2) &= A(x, y) & \text{where } A &\equiv xyxz \\ \rho(Z^1) &= B(z) & \text{where } B &\equiv xzy \\ \rho(Z^0) &= u. \end{aligned}$$

Then  $\rho(H) \equiv \rho Z^2(\rho Z^2(\rho Z^0, \rho Z^0), \rho Z^1(\rho Z^0)) \equiv$  the unique result of a complete  $\underline{\beta}_m$ -development of  $(\underline{\lambda xy}.A(x, y))((\underline{\lambda xy}.A(x, y))uu)((\underline{\lambda z}.B(z))u) \equiv uuuz(xuy)(uuuz)z$ .



1.11. DEFINITION. (1) A reduction rule (in ACZEL [78]: contraction scheme) is a pair  $(H_1, H_2)$  of meta-terms, written as  $H_1 \rightarrow H_2$ , such that

- (i) the top of  $\tau(H_1)$  is a constant  $Q_1$ ,
- (ii)  $H_1, H_2$  are closed,
- (iii) the meta-variables in  $H_2$  occur already in  $H_1$ ,
- (iv) the meta-variables  $Z_i^k$  in  $H_1$  occur only at end-nodes of  $\tau(H_1)$  in the form  $Z_i^k(\vec{x})$ , where  $\vec{x} = x_1, \dots, x_k$  is a string of pairwise distinct variables.

(2) If, moreover, no metavariable occurs twice in  $H_1$ , the reduction rule  $H_1 \rightarrow H_2$  is called *left-linear*.

(3) The reduction rule  $H_1 \rightarrow H_2$  defines a *reduction relation*, which also will be denoted as  $\rightarrow$ , on  $\text{Ter}$ , as follows:

$$\mathbb{C}[\rho(H_1)] \rightarrow \mathbb{C}[\rho(H_2)]$$

for every context  $\mathbb{C}[\ ]$  (defined analogously as for  $\lambda\beta$  in I.1.5) and every valuation  $\rho$ .

If  $r = H_1 \rightarrow H_2$ , then we will also write  $\xrightarrow{r}$  for the reduction relation defined by  $r$ . A term of the form  $\rho(H_1)$  for some valuation  $\rho$  is called an *r-redex*.

As usual,  $\twoheadrightarrow$  denotes the transitive reflexive closure of  $\rightarrow$ .

1.12. EXAMPLES. (i)

$$\begin{array}{ccc} & \lambda & \\ & / \quad \backslash & \\ [x] & & Z_0^0 \\ & | & \\ & Z_0^1(x) & \end{array} \longrightarrow Z_0^1(Z_0^0)$$

is the rule of  $\beta$ -reduction. Henceforth we will omit the superscripts of meta-variables, indicating their arity, and write  $Z, Z_1, Z_2, Z', Z'', \dots$ . Sometimes we will write instead of a meta-term its formation tree, as above, since it often makes the structure of the meta-term more apparent.

(ii) The definition of the recursor  $R$  yields an example of two left-linear reduction rules where no substitution is involved (so with only 0-ary meta-variables):

$$\begin{array}{l} R Z_1 Z_2 0 \longrightarrow Z_1 \\ R Z_1 Z_2 (SZ_3) \longrightarrow Z_2 Z_3 (RZ_1 Z_2 Z_3) \end{array}$$

(iii) The reduction rules for 'Surjective Pairing', which we will consider in Chapter III, yield an example of a non left-linear reduction rule (the third one):

$$\begin{aligned} \mathcal{D}_0(\mathcal{D}z_0 z_1) &\longrightarrow z_0 \\ \mathcal{D}_1(\mathcal{D}z_0 z_1) &\longrightarrow z_1 \\ \mathcal{D}(\mathcal{D}_0 z) (\mathcal{D}_1 z) &\longrightarrow z \end{aligned}$$

(iv) A pathological example:

$$\begin{array}{ccc} & \mathcal{Q} & \longrightarrow z_1(z_2(z_1(I))) \\ & \swarrow \quad \searrow & \\ [x] & & [y] \\ | & & | \\ z_1(x) & & z_2(y) \end{array}$$

Let us give an example of an actual reduction step induced by this reduction rule. Let  $\rho z_1 = A(x)$  where  $A \equiv xxK$  and  $\rho z_2 = B(y)$  where  $B \equiv yS$ , then  $\rho(z_1(x)) = xxK$  and  $\rho(z_2(y)) = yS$ , and we have as an instance of the reduction rule the following reduction step:

$$\begin{aligned} \mathcal{Q}([x](xxK))([y](yS)) &\longrightarrow \\ [x:= [y:= [x:=I](xxK)](yS)](xxK) &\equiv \\ [x:= [y:= \quad \quad \quad IIK](yS)](xxK) &\equiv \\ [x:= \quad \quad \quad \quad \quad \quad \quad IIKS](xxK) &\equiv \\ IIKS(IIKS)K. & \end{aligned}$$

(v) The next example is from Proof Theory; see PRAWITZ [71], p.252. In a normalization procedure for derivations (in 'Natural Deduction') we have here the 'v-reductions' ( $i = 1, 2$ ):

$$\begin{array}{ccc} \frac{z_0}{\phi_i} & \frac{[\phi_1]}{z_1} & \frac{[\phi_2]}{z_2} & \frac{z_0}{[\phi_i]} \\ \mathcal{Q}_i \frac{\frac{\phi_1 \vee \phi_2}{\psi}}{\phi_1 \vee \phi_2} & \frac{\psi}{\psi} & \frac{\psi}{\psi} & \frac{z_1}{\psi} \\ \mathcal{P} \frac{\frac{\phi_1 \vee \phi_2}{\psi}}{\phi_1 \vee \phi_2} & & & \frac{z_1}{\psi} \end{array} \longrightarrow$$

Here  $\mathcal{Q}_i$ ,  $\mathcal{P}$  are 'rule-constants' for the v-introduction and v-elimination

rule. Omitting the formulae  $\phi_1, \psi$  which function as 'types' of the derivations  $Z_0, Z_1, Z_2$ , these reductions can be written linearly as follows:

$$P(Q_1 Z_0) ([x]Z_1(x)) ([y]Z_2(y)) \longrightarrow Z_1(Z_0).$$

(Likewise one can consider the  $\&-$ ,  $\supset-$ ,  $\forall-$ ,  $\exists-$  reductions in PRAWITZ [71] p.252,253; these 5 proper reductions together constitute a regular CRS. The  $\forall E$ -reductions induce an ambiguity however. See Def.1.14 and 1.16. for the concepts 'ambiguous' and 'regular'.)

$$(vi) \quad (\lambda[x].Z_1(x))Z_2 \longrightarrow P(Z_1(Z_2))Z_2$$

' $\beta$ -reduction with memory'; see Section 4.

1.13. DEFINITION. If  $H, H'$  are meta-terms, we write  $H \subseteq_{\sigma} H'$  to indicate that the subterm  $H$  "occurs at place  $\sigma$ " in  $H'$ . Here the sequence numbers  $\sigma = \langle n_1, \dots, n_k \rangle$  ( $k \geq 0$ ) are possibly empty sequences of natural numbers, designating the nodes in a tree  $\tau(H)$  as in the figure:

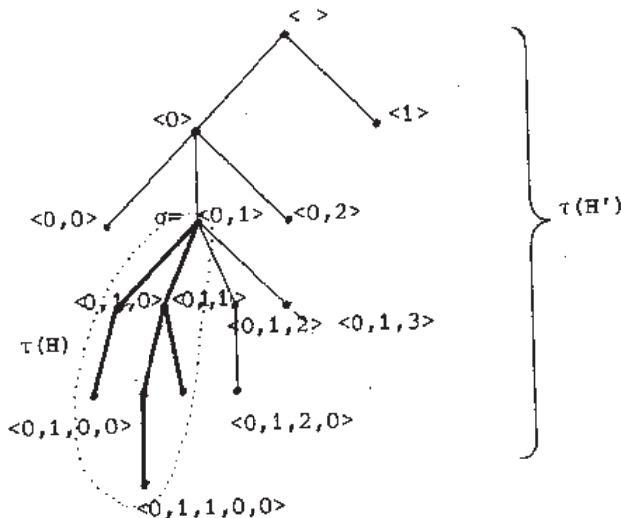

So  $H \subseteq_{\langle 0,1 \rangle} H'$ .

REMARK. A shortcoming of the formation trees  $\tau(H')$  is that the nodes  $\sigma$  in  $\tau(H')$  are not in bijective correspondence with the subterm occurrences in  $H'$ , as is apparent from the figure above. (If one uses Aczel's notation as explained in Remark 1.5 above, and the corresponding formation trees, then this shortcoming is removed.) However, for our purposes the trees  $\tau(H')$  suffice.

We illustrate the next definition by some examples.

(i) Consider a CRS  $\Sigma$  with the set of reduction rules

$$\text{Red}(\Sigma) = \{r_1 : P(QZ) \longrightarrow A, r_2 : QZ \longrightarrow B\}.$$

Then the fact that the  $r_1$ -redex  $R_1 \equiv P(Q(\rho Z))$  contains as subterm a  $r_2$ -redex  $R_2 \equiv Q(\rho Z)$  is undesirable if one wants to have the CR-property.

(For  $R_1 \longrightarrow A$  and also  $R_1 \longrightarrow PB$  and there is no common reduct of  $A, PB$ )

(ii) A more subtle case of this kind of "interference" between reduction rules is given by

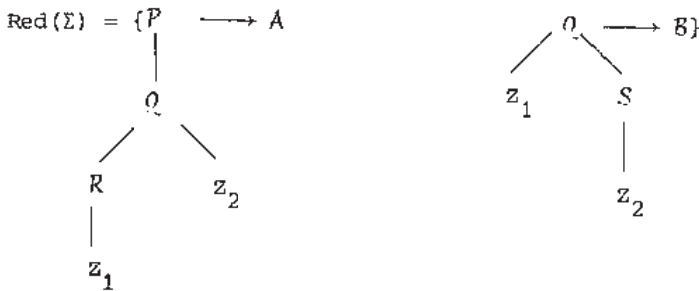

Here, too, there is 'interference'; namely if  $R \equiv$   
 for some terms  $X, Y$ , then  $R \longrightarrow A$  and also  
 $R \longrightarrow PB$ .

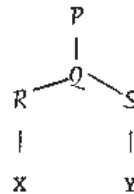

(iii) A reduction rule may also interfere with itself (example of HUET [78]):

if  $\text{Red}(\Sigma) = \{P(PZ) \longrightarrow A\}$  and  $R \equiv P(P(PX))$ , then  $R \longrightarrow A$  and  $R \longrightarrow PA$ .

This leads us to:

## 1.14. DEFINITION.

(1) Let  $H_1, H_2 \in \text{Mter}$ . Then  $H_1 \Subset H_2$  (" $H_1$  interferes with  $H_2$ ")  $\Leftrightarrow$

(i) if  $H_1 \equiv H_2$ : for some  $\rho$  and non-terminal  $\sigma \neq \langle \rangle$  in  $H_2$ ,  
 $\rho H_1 \subseteq_{\sigma} \rho H_2$ .

(ii) if  $H_1 \neq H_2$ : for some  $\rho$  and non-terminal  $\sigma$  in  $H_2$ ,  $\rho H_1 \subseteq_{\sigma} \rho H_2$ .

An equivalent definition is:

$H_1 \not\Subset H_2$  iff whenever  $\rho H_1 \not\subseteq \rho H_2$ , then  $\rho H_1 \subseteq \rho Z$  for some metavariable  $Z$  in  $H_2$ .

(2) If  $r_1 = H_1 \rightarrow H'_1$  and  $r_2 = H_2 \rightarrow H'_2$  are two reduction rules (possibly the same) of a CRS, we say that  $r_1$  interferes with  $r_2$  iff  $H_1 \Subset H_2$ .

(3) Let  $\text{Red}(\Sigma) = \{r_i = H_i \rightarrow H'_i \mid i \in I\}$  be the set of reduction rules of a CRS  $\Sigma$ .

Then  $\text{Red}(\Sigma)$  (or just  $\Sigma$ ) is *non-ambiguous* iff

(i)  $H_i \not\Subset H_j$  for  $i \neq j$ ,

(ii) for no  $i, j \in I$ ,  $r_i$  interferes with  $r_j$ .

## 1.15. EXAMPLES.

(1)  $\text{Red}(\Sigma) = \{IZ \rightarrow Z\}$  is non-ambiguous, but  $\text{Red}(\Sigma') = \{I(IZ) \rightarrow IZ\}$  is.

(2)  $\text{Red}(\Sigma) = \{(\lambda x.z_1(x))z_2 \rightarrow z_1(z_2) \text{ (}\beta\text{-reduction)},$   
 $(\lambda x.xx)(\lambda x.xx) \rightarrow \lambda x.x\}$

is ambiguous.

(3) The following example is from ACZEL [78]. Let  $\Sigma$  have the rules:

$\beta$ -reduction

pairing:  $D_0(Dz_1z_2) \rightarrow z_1$   
 $D_1(Dz_1z_2) \rightarrow z_2$

definition by cases:

$$\begin{array}{ccc} R_{n-1}^0 z_1 \dots z_n & \rightarrow & z_1 \\ \vdots & & \vdots \\ R_{n-1}^0 z_1 \dots z_n & \rightarrow & z_n \end{array}$$

iterator:

$$\begin{array}{ccc} J_0 z_1 z_2 & \rightarrow & z_2 \\ J(Sz_0)z_1 z_2 & \rightarrow & z_1(Jz_0 z_1 z_2). \end{array}$$

Then  $\Sigma$  is a non-ambiguous CRS.

(Note that the rules for  $R_2$  above are similar to the rules:

$$\begin{array}{l} \text{if true then } Z_1 \text{ else } Z_2 \longrightarrow Z_1 \\ \text{if false then } Z_1 \text{ else } Z_2 \longrightarrow Z_2. \end{array}$$

(4) Church's  $\delta$ -rule. See CHURCH [41] p.62.

Let  $\Sigma$  be  $\lambda\beta$ -calculus plus the rules

$$\begin{array}{l} \delta AB \longrightarrow I \text{ if } A \equiv B \text{ and } A, B \text{ are closed normal forms} \\ \delta AB \longrightarrow KI \text{ if } A \not\equiv B \text{ and } A, B \text{ are closed normal forms.} \end{array}$$

In fact one should write, as pointed out in HINDLEY [78]:

$$\text{Red}(\Sigma) = \{\beta\} \cup \{\delta AB \longrightarrow I \mid A, B \text{ closed nf's, } A \equiv B\} \cup \\ \{\delta AB \longrightarrow KI \mid A, B \text{ closed nf's, } A \not\equiv B\}$$

to see that  $\Sigma$  is a CRS. Note that the infinitely many  $\delta$ -reduction rules have no metavariables. Clearly,  $\Sigma$  is non-ambiguous.

$$(5) \text{ Red}(\Sigma) = \{Z_1 + Z_2 \longrightarrow Z_2 + Z_1 \\ Z_1 + SZ_2 \longrightarrow S(Z_1 + Z_2) \\ (Z_1 + Z_2) + Z_3 \longrightarrow Z_1 + (Z_2 + Z_3)\}$$

is ambiguous, in several ways. (Here  $Z_1 + Z_2$  stands for  $+ Z_1 Z_2$ .)

(6) The following very familiar CRS  $\Sigma$  has constants 0 (zero), S (successor), A (addition), M (multiplication), and E (exponentiation).

$$\text{Red}(\Sigma) = \{AZ_0 \longrightarrow Z, AZ_1(SZ_2) \longrightarrow S(AZ_1 Z_2), \\ MZ_0 \longrightarrow 0, MZ_1(SZ_2) \longrightarrow A(MZ_1 Z_2)Z_1, \\ EZ_0 \longrightarrow S_0, EZ_1(SZ_2) \longrightarrow M(EZ_1 Z_2)Z_1\}.$$

The rules are non-ambiguous and left-linear.

1.16. **DEFINITION.** Let  $\text{Red}(\Sigma)$  be non-ambiguous and let the reduction rules in  $\text{Red}(\Sigma)$  be left-linear (Def.I.11.(2)). Then  $\Sigma$  is called a *regular* CRS.

1.17. **REMARK.** The definition of CRS's is, loosely speaking, the union of the definitions of

- (i) the *contraction schemes* in ACZEL [78],
- (ii) the *Term Rewriting Systems* as in e.g. HUET [78],
- (iii) the  $\lambda(a)$ -reductions of HINDLEY [78].

(See Figure 1.18.)

Ad(i). Aczel's contraction schemes are less general than CRS's, since there in a scheme  $H \longrightarrow H'$ , the formation tree  $\tau(H)$  has typically the form

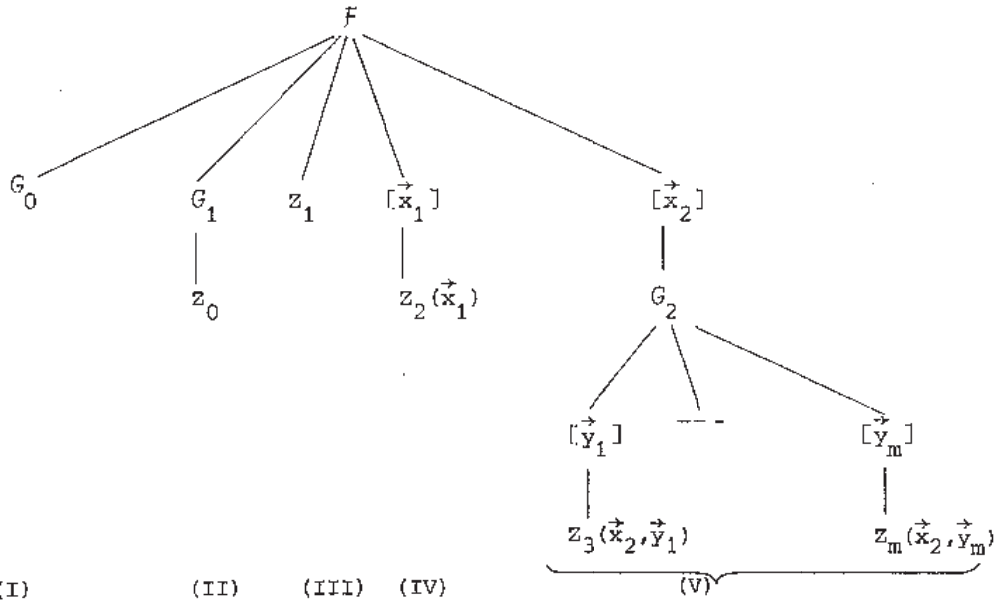

I.e. all the 'arguments' of  $F$  can only have the form (I), ..., (V). Here (I), (II) are special cases of the form (V) and (III) is a special case of (IV). So the meta-terms  $H$  in the LHS' of contraction schemes in ACZEL [78] have a *limited depth* (viz. 4). In our definition  $\tau(H)$  can be arbitrarily deep, hence the concept of a CRS also covers that of a TRS.

ad(iii). Hindley's  $\lambda(a)$ -reductions generalize the class of regular (i.e. non-ambiguous, left-linear) TRS's. In a reduction rule  $H \rightarrow H'$ , Hindley admits only 0-ary metavariables (apart from the rule  $\beta$ ).

Among Hindley's  $\lambda(a)$ -reductions are the so-called  $\delta$ -rules of Church. These are of the form

$$A_1 \dots A_n \longrightarrow B$$

where the  $A_i$  ( $i = 1, \dots, n$ ) and  $B$  are closed terms and the  $A_i$  are moreover in  $\beta\delta$ -normal form. So they are reduction 'rules' without metavariables; each rule has only one instance, namely itself. Moreover the set of these rules has to be non-ambiguous. An example was given in 1.15(4).

A subclass of Hindley's  $\lambda(a)$ -reductions and Aczel's contraction schemes was considered in STENLUND [72]. There the CR theorem is proved for  $\lambda\beta\eta\delta\mathcal{R}$ -calculus;  $\eta$  refers to  $\eta$ -reduction which we do not consider except in Chapter IV,  $\delta$  refers to Church's  $\delta$ -reductions and  $\mathcal{R}$ -reductions are a generalization of the usual recursor as in Example 1.12(ii). An inspection of Stenlund's definition shows that (when  $\eta$  is left aside) his  $\lambda\beta\delta\mathcal{R}$  is a regular CRS.

A note on terminology: instead of 'non-ambiguous' ACZEL [78] calls such a  $\Sigma$  consistent, HUET [78] says that such a  $\Sigma$  (for TRS's) has no critical pairs, and ROSEN [73] speaks of the non-overlapping condition. In HINDLEY [78] the non-ambiguity of  $\Sigma$  is about the same as his (D2) & (D5) & (D6); (D3) is the left-linearity.

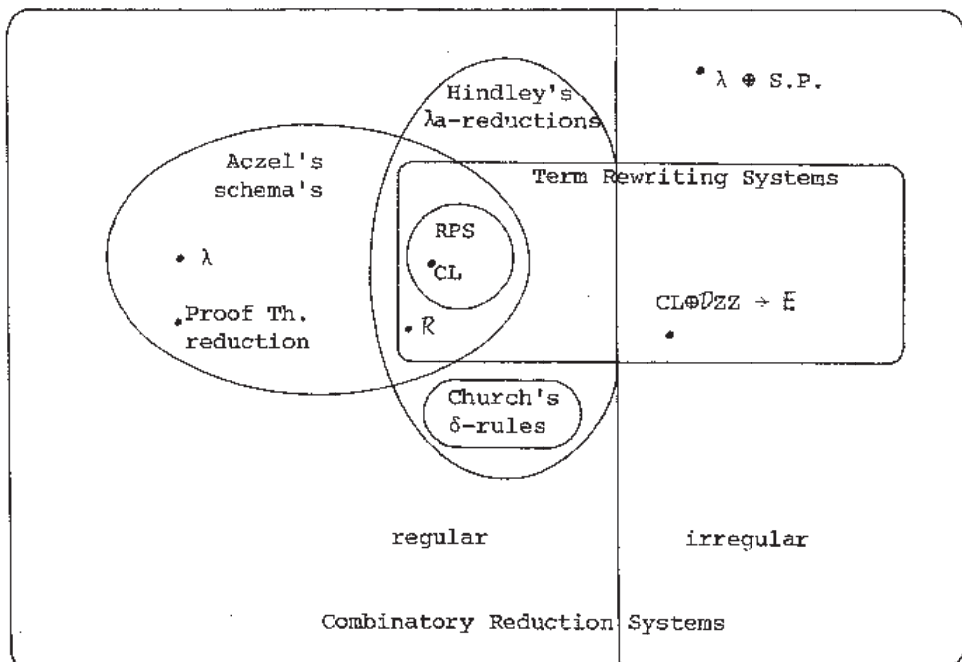

Venn diagram of the extensions of various notions of reduction.

Here 'RPS' is the class of Recursive Program Schemes, as in I.1.13; ' $\lambda @ S.P.$ ' refers to the example in 1.12(iii); 'Proof Th. reduction' refers to the reduction rule in Example 1.12.(v), 'R' stands for the recursor (Example



1.12.(ii), and  $CL \oplus \mathcal{O}ZZ \rightarrow \bar{E}$  refers to a non-left-linear extension of CL which will be considered in Chapter III.

In order to facilitate notation, let us define the following operation on CRS's.

1.19. DEFINITION. (i) Let  $\Sigma_1, \Sigma_2$  be CRS's having disjoint sets of constants. Then the direct sum  $\Sigma_1 \oplus \Sigma_2$  is the CRS having as alphabet the union of the alphabets of  $\Sigma_1, \Sigma_2$  and such that  $\text{Red}(\Sigma_1 \oplus \Sigma_2) = \text{Red}(\Sigma_1) \cup \text{Red}(\Sigma_2)$ .

(ii) If  $\Sigma_1, \Sigma_2$  are CRS's not satisfying the disjointness requirement in (i), we take 'isomorphic copies'  $\Sigma_1'$  and  $\Sigma_2'$  (e.g. by replacing each constant  $Q$  of  $\Sigma_i$  by  $Q^{(i)}$  ( $i = 1, 2$ )) and put  $\Sigma_1 \oplus \Sigma_2 := \Sigma_1' \oplus \Sigma_2'$

1.19.1. EXAMPLE. (i)  $\lambda \oplus CL$  as in Def.1.2.5.1.

(ii)  $CL \oplus CL$  has constants  $I, I', K, K', S, S'$  and rules  $Iz \rightarrow z, I'z \rightarrow z$  and likewise for  $K, S$ .

1.19.2. REMARK. Although we will not explore the properties of  $\oplus$  systematically, we will state some observations on  $\oplus$ :

(i) the class of CRS's is closed under  $\oplus$ ; likewise the class of regular CRS's.

(ii) if  $\Sigma_1, \Sigma_2$  are CRS's, then

$$\Sigma_1 \oplus \Sigma_2 \models CR \Rightarrow \Sigma_1 \models CR \ \& \ \Sigma_2 \models CR$$

but the converse does not hold, as we will see in Ch.III. If moreover  $\Sigma_1, \Sigma_2$  are regular CRS's, the converse holds trivially, by (i) and because every regular CRS is CR (Thm.3.11).

(iii) According to Def.1.5.10.(1), a CRS  $\Sigma$  is consistent iff not every two  $\Sigma$ -terms (including open  $\Sigma$ -terms, i.e. containing variables) are convertible by means of the reduction rules. In particular, iff  $\Sigma \not\models x = y$  for different variables  $x, y$ . Now we have

$$\Sigma_1 \oplus \Sigma_2 \text{ consistent} \Leftrightarrow \Sigma_1, \Sigma_2.$$

Here  $\Rightarrow$  is obvious, and to see  $\Leftarrow$ , let  $\Sigma_1$  be CL and  $\Sigma_2$  be the CRS having constants  $P, Q$  and as only rules  $Pz \rightarrow z$  and  $Pz \rightarrow Zz$ . Then in  $\Sigma_1 \oplus \Sigma_2$ :

$$\begin{aligned} PKIxy &\longrightarrow KIxy \longrightarrow Iy \longrightarrow y \\ &\longrightarrow KKIxy \longrightarrow Kxy \longrightarrow x. \end{aligned}$$

When  $\Sigma_1, \Sigma_2$  are moreover regular, then the converse implication does hold, as a consequence of (ii).

(iv) As for the property Strong Normalization, we remark that obviously

$$\Sigma_1 \oplus \Sigma_2 \models SN \Rightarrow \Sigma_1 \models SN \ \& \ \Sigma_2 \models SN; \text{ but again not conversely.}$$

A counterexample is given by the regular TRS's  $\Sigma_1$  having  $K$  as only constant and as only rule  $KZZ' \rightarrow Z$ , and  $\Sigma_2$  having constants  $P, Q$  and as only rule  $P(QZ) \rightarrow ZPP(QZ)$ .

Then trivially  $\Sigma_1 \models SN$ , and also  $\Sigma_2 \models SN$ , since in  $\Sigma_2$  no new redexes can be created (therefore  $\Sigma_2 = \Sigma_2$ , and by Theorem 4.15 below:  $\Sigma_2 \models SN$ ).

On the other hand,  $\Sigma_1 \oplus \Sigma_2 \not\models SN$ , because  $P(QK) \rightarrow KPP(QK) \rightarrow P(QK)$ .

(Question: does the converse implication hold if  $\Sigma_1, \Sigma_2$  are both RPS's?)

1.20. REMARK. In the study of CRS's we consider, next to the Term Rewriting part, reductions involving general mechanisms of variable-binding. One can ask whether this is necessary: it might be thought that the way of variable-binding and substitution as in  $\lambda$ -calculus ('the theory of functional abstraction') is sufficient, especially in view of a remark in CURRY-FEYS [56] p.85,86 in which it is stated that "any binding operation can in principle be defined in terms of functional abstraction and an ordinary operation", and that "the theory of functional abstraction is tantamount to the theory of bound variables."

A similar remark is made in CHURCH [56] §06, p.41: here  $\lambda$  is called the 'singular functional abstraction operator', and it is stated that "all other operators can in fact be reduced to this one".

Indeed it is not hard to see that for the notation of terms, the operator  $\lambda$  suffices. In CURRY, FEYS [56] examples like ' $(\exists x)X \equiv \Sigma(\lambda x.X)$ ' are given to that effect.

As to reduction of terms, however, and the corresponding syntactical questions such as the Church-Rosser Theorem, the Parallel Moves Lemma, it seems to us that one cannot claim that the theory of bound variables is tantamount to that of  $\lambda$ -abstraction. Let us try to make this more precise:

DEFINITION. Let  $\Sigma$  be a CRS such that  $\text{Red}(\Sigma)$  contains the rule

$\beta = (\lambda x.Z(x))Z' \rightarrow Z(Z')$  as only substituting rule, next to Term Rewriting

rules. Then we will call  $\Sigma$  a  $\lambda$ -TRS.

EXAMPLE.  $\lambda \oplus \text{CL}$  is a  $\lambda$ -TRS; in general, if  $\Sigma$  is a TRS, then  $\lambda \oplus \Sigma$  is a  $\lambda$ -TRS. The converse does not hold, e.g. if  $\Sigma$  is such that  $\text{Red}(\Sigma) = \{\beta, Pz_1 z_2 \longrightarrow \lambda z. z_2 (z_1 z)\}$  ( $z_1, z_2$  0-ary metavariables) then  $\Sigma$  cannot be written as  $\lambda \oplus$  some TRS.

REMARK. Hindley's  $\lambda(a)$ -reduction systems are in fact regular  $\lambda$ -TRS's.

Now we can interpret the statement from CURRY-FEYS [56], cited above, as claiming that 'the theory of CRS's is tantamount to the theory of  $\lambda$ -TRS's'.

Indeed, it is not hard to show that for every CRS  $\Sigma$  there is a  $\lambda$ -TRS  $\Sigma^*$ , having the same terms (modulo inessential notational differences) and such that for all terms A,B:

- (i)  $\Sigma \models A \longrightarrow B \Rightarrow \Sigma^* \models A \twoheadrightarrow B$ , and hence also  
 (ii)  $\Sigma \models A \twoheadrightarrow B \Rightarrow \Sigma^* \models A \longrightarrow B$ .

As a typical example, let  $\Sigma$  have the rule

$$r = P([x]Z'(x))([y]Z''(y)) \longrightarrow \lambda z. Z''(Z'(z))$$

( $Z'$ ,  $Z''$  unary metavariables) then  $\Sigma^*$  will have instead of  $r$  the rule  $r^* = Pz_1 z_2 \longrightarrow \lambda z. z_2 (z_1 z)$  ( $z_1, z_2$  0-ary metavariables).

And now for terms  $C_1[x]$ ,  $C_2[y]$  we have in  $\Sigma$ :

$$P([x]C_1[x])([y]C_2[y]) \xrightarrow{r} \lambda z. C_2[C_1[z]]$$

in one step, while in  $\Sigma^*$ :

$$\begin{aligned} P(\lambda x. C_1[x])(\lambda y. C_2[y]) &\xrightarrow{r^*} \\ \lambda z. (\lambda y. C_2[y])((\lambda x. C_1[x])z) &\xrightarrow{\beta} \xrightarrow{\beta} \\ \lambda z. C_2[C_1[z]]. & \end{aligned}$$

However, in general the converse implication does not hold in (ii) above:  $\Sigma^*$  has too many reduction possibilities. So to prove e.g. the CR theorem for  $\Sigma$  it does not help, a priori, to have CR for  $\Sigma^*$ .

In fact, it seems to us that the theory of CRS's is a refinement of that for  $\lambda$ -TRS's; essentially the refinement amounts to the fact that many step reductions such as in the example for  $\Sigma^*$  above can be dealt with as a single step (in  $\Sigma$ ).

Furthermore, let us mention that reductions like  $r$  in  $\Sigma$  above, do indeed in a natural way occur: namely in Proof Theory (see Example 1.12(v)); we will return to that later.

Finally: our wish to consider more general variable-binding mechanisms arose also in order to have maximum flexibility in defining 'odd' reductions, like e.g.  $\beta_{[\cdot, \cdot]}$  (as in Example 1.12(vi), (vii)).

## 2. DESCENDANTS AND LABELS FOR COMBINATORY REDUCTIONS

The following definitions are analogous to Def.I.3.1 and I.3.2. for  $\lambda\beta$ -calculus. To each CRS  $\Sigma$  we assign a 'labeled' CRS  $\Sigma_A$ .

**2.1. DEFINITION.** Let  $\Sigma$  be a CRS and  $A = \{\emptyset, a, b, \dots\}$  be a set of labels, including the empty label  $\emptyset$ . Then  $M = \text{Mter}(\Sigma_A)$ , the set of meta-terms of  $\Sigma_A$ , is defined inductively as follows:

- (i)  $a \in A, x \in \text{Var}, Q$  a constant of  $\Sigma \Rightarrow (ax), (aQ) \in M$
- (ii)  $a \in A, x \in \text{Var}, A \in M \Rightarrow (a([x]A)) \in M$
- (iii)  $a \in A, A, B \in M \Rightarrow (a(AB)) \in M$
- (iv)  $Z_i^k \in \text{Mvar}, A_1, \dots, A_k \in M \Rightarrow Z_i^k(A_1, \dots, A_k) \in M$  (all  $i, k \geq 0$ ).

### 2.2. NOTATION.

(1) Instead of  $(aA)$  we will write  $A^a$ ; we used the notation  $(aA)$  to show that the labeling can be seen as 'internal', i.e. that a labeled combinatory reduction is just another combinatory reduction where the labels are new constants.

(2) Instead of  $A^\emptyset$  we will write  $A$ . Hence  $\text{Mter}(\Sigma) \subseteq \text{Mter}(\Sigma_A)$ .

(3) Note that meta-terms  $Z_i^k(A_1, \dots, A_k)$  ( $i, k \geq 0$ ) do not carry labels; there is no need for that, since the metavariables  $Z$  will be metavariables for labeled terms in  $\Sigma_A$ .

(4) Analogous to Def.I.3.1, we will write  $\Sigma_A$ -meta-terms also in the form  $A^I$  where  $A \in \text{Mter}(\Sigma)$  and  $I$  is a labeling of the subterms of  $A$ .

**2.3. DEFINITION.** (i) To each reduction rule  $r \in \text{Red}(\Sigma)$  we associate a set  $r_A$  of reduction rules:

if  $r = H \rightarrow H'$ , then  $(H^I \rightarrow H') \in r_A$  for every labeling  $I$ .

(ii)  $\text{Red}(\Sigma_A) = \cup \{r_A \mid r \in \text{Red}(\Sigma)\}$ .

2.4. EXAMPLE. (1) If  $r = Sz_1z_2z_3 \rightarrow z_1z_3(z_2z_3)$ , then  $r_A$  consists of all reduction rules

$$((S^a z_1)^b z_2)^c z_3)^d \rightarrow z_1 z_3 (z_2 z_3)$$

for all  $a, b, c, d \in A$ .

(2) If  $r = \beta$ -reduction rule, then  $r_A$  consists of all rules

$$((\lambda^a ([x]z_1(x))^{a'})^b z_2)^c \rightarrow z_1(z_2)$$

for all  $a, a', b, c \in A$ .

(Cf. the definition of  $\beta_A$ -reduction in I.3.2. To get the latter, take  $a, a' = \emptyset$ ; so  $r_A$  contains all rules

$$((\lambda x. z_1(x))^b z_2)^c \rightarrow z_1(z_2),$$

i.e.  $\beta_A$ -reduction.)

2.5. DEFINITION. Let  $A^I \in \text{Mter}(\Sigma_A)$ . We call  $I$  an *initial* labeling of  $A$  if  $I$  labels all the sub-meta-terms of  $A$  by a different label  $\neq \emptyset$ .

It is now a simple matter to define the concept of descendants for regular CRS's. (In fact the definition applies to left-linear CRS's.) First we need a proposition.

2.6. PROPOSITION. (i) Let  $\Sigma$  be a CRS. Then  $\Sigma_A$  is a CRS. Moreover:

$\text{Red}(\Sigma)$  is non-ambiguous  $\Rightarrow \text{Red}(\Sigma_A)$  is non-ambiguous.

$\text{Red}(\Sigma)$  is left-linear  $\Rightarrow \text{Red}(\Sigma_A)$  is left-linear.

(Hence, if  $\Sigma$  is a regular CRS, then  $\Sigma_A$  is one.)

(ii) Let  $\Sigma$  be a left-linear CRS. If  $M \xrightarrow[r]{R} M'$  is a reduction step in  $\Sigma$ , then there is a unique labeled rule  $r' \in r_A$  such that  $M^I \xrightarrow[r']{R^J} M'^{I'}$  where  $R^J$  is the contracted  $r'$ -redex corresponding to the  $r$ -redex  $R$  in  $M$ .

PROOF. (i) The main point to check is that  $\text{Red}(\Sigma_A)$  is again non-ambiguous. Suppose not, and consider an ambiguity. Then it is not hard to see that erasing the labels yields an ambiguity in  $\text{Red}(\Sigma)$ .

(ii) Routine.  $\square$

2.6.1. REMARK. The restriction in Proposition 2.6(ii) to left-linear CRS's is necessary. For, let  $\Sigma$  have as only rule  $r = \mathcal{D}ZZ \rightarrow Z$ ; so  $\Sigma_A$  has the set of rules  $r_A = \{(\mathcal{D}^a Z)^b Z \rightarrow Z \mid a, b \in A\}$ . Now consider  $M \equiv \mathcal{D}xx \xrightarrow{r} x \equiv M'$  and take  $M^I \equiv (\mathcal{D}^a x^p)^b x^q$  for  $p \neq q$ ; then none of the  $r_A$ -rules applies to  $M^I$ .

2.7. DEFINITION. Let  $\Sigma$  be a left-linear CRS. Consider a step  $M \xrightarrow{r} M'$  in  $\Sigma$  and a subterm  $N \subseteq M$ . "Lift" this reduction step to the step  $M^I \xrightarrow{r'} M'^I$  in  $\Sigma_A$ , where  $I$  is some initial labeling and  $r'$  is the suitable rule  $\in r_A$  (unique by Proposition 2.6).

Then the *descendant(s)*  $N' \subseteq M'$  of  $N$  are those subterms of  $M'$  bearing the same label as  $N$ .

2.8. REMARK. (1) Note that since the right hand side of  $r' = (H^I \rightarrow H^I) \in r_A$  is unlabeled, an  $r$ -redex  $\rho(H)$  has no descendants after its contraction.

(2) Descendants of a redex will also be called *residuals*.

(3) Note that, contrary to the case of  $\lambda\beta$ , in general in a step  $M \rightarrow M'$  not every subterm  $N' \subseteq M'$  has an ancestor  $N \subseteq M$  (i.e. a subterm  $N$  of which  $N'$  is a descendant). We remarked this already for CL in Example I.3.4.7. However, if  $N'$  has an ancestor  $N \subseteq M$ , it is unique, since  $I$  was an initial labeling in Def.2.7.

2.9. To every regular CRS  $\Sigma$  we will associate an underlined version,  $\underline{\Sigma}$ . (Cf. I.3.5 and I.3.6 where  $\underline{\lambda}$  is defined.)

2.10. DEFINITION. Let  $\Sigma$  be a regular CRS, having  $Q$  as set of constants. Let  $\underline{Q}$  be the set  $\{\underline{Q} \mid Q \in Q\}$ . Now define  $\underline{\Sigma}$  to be the CRS such that

(i) the set of constants of  $\underline{\Sigma}$  is  $Q \cup \underline{Q}$ ,

(ii)  $r = (M \rightarrow H') \in \text{Red}(\Sigma)$ , then  $\underline{r} = (\underline{M} \rightarrow H')$ .

(Note:  $Q$ 's occurring in  $M, H'$  are not underlined in  $\underline{r}$ .)

2.11. REMARK. (1)  $\underline{\Sigma} \subseteq \Sigma_{\{0,1\}}$ ; or more precisely,  $\underline{\Sigma}$  can be 'isomorphically embedded' (in the usual sense) into  $\Sigma_{\{0,1\}}$ .

(Cf. the definition of  $\underline{\lambda}$  from  $\lambda_{\{0,1\}}$  in I.3.5.)

Hence by Proposition 2.6,  $\underline{\Sigma}$  is again a regular CRS. (Obviously,  $\Sigma' \subseteq \Sigma$  &  $\Sigma$  is regular  $\Rightarrow \Sigma'$  is regular.) One can also check directly that:  $\Sigma$  regular  $\Rightarrow \underline{\Sigma}$  regular; we will omit the routine verification.

(2) The main feature of  $\underline{\Sigma}$  is that in  $\underline{\Sigma}$ -reductions  $M \rightarrow \dots \rightarrow N$  there is no creation of  $\underline{\Sigma}$ -redexes; cf. the analogous case of  $\lambda\beta$ . I.e. in a  $\underline{\Sigma}$ -step  $A \rightarrow B$  every  $\underline{\Sigma}$ -redex in  $B$  is a residual of a  $\underline{\Sigma}$ -redex in  $A$ . Again the verification of this fact is routine.

2.12. DEFINITION. (i) Let  $\Sigma$  be a regular CRS and  $\underline{\Sigma}$  the underlined version. If  $\mathcal{R}'$  is a  $\underline{\Sigma}$ -reduction and  $\mathcal{R}$  is the  $\Sigma$ -reduction obtained by erasing the underlining (i.e. replacing  $\underline{Q}$  by  $Q$ ), then we will call  $\mathcal{R}$  a ( $\Sigma$ -) *development*. Par abus de langage, we will call sometimes also  $\mathcal{R}'$  a development. (ii) If, moreover,  $\mathcal{R}'$  terminates in a  $\underline{\Sigma}$ -normal form,  $\mathcal{R}$  will be called a *complete* ( $\Sigma$ -) development. (Note that  $\mathcal{R}$  does not necessarily end in a  $\Sigma$ -normal form; cf. the case for  $\lambda\beta$ .)

2.13. REMARK. (i) The '*disjointness property*' (Def.I.4.3.1), stating that the descendants of a subterm are disjoint, and which was seen to hold for one-step reductions in  $\lambda\beta$ -calculus and even for  $\beta$ -developments (I.4.3.7), fails here at once: consider e.g. a rule

$$Q[x]Z(x) \longrightarrow Z(Z(I)).$$

(ii) O'DONNELL [77] states on p.89 (def.22') some axioms for 'pseudoresiduals' and on p. 23 (Def. 22) for residuals. These axioms require some well-behaviour of his pseudoresiduals. The residuals which we have introduced above for CRS's do not fall under the scope of O'Donnell's definition, since our residuals can be very much entwined even after one step, (which is forbidden in O'Donnell's definition), e.g.:

$$Q([x]Z_1(x))([y]Z_2(y)) \longrightarrow Z_1(Z_2(Z_1(Z_2(I)))).$$

(iii) It is simple to see that Lévy's  $\lambda^L$ -calculus (see I.3.9), typed  $\lambda$ -calculus (I.3.8) and  $\lambda^{HW}$ -calculus (I.3.7) are regular CRS's. (I.e. the L-labeling and the HW-labeling can be viewed as 'internal'.) E.g.  $\lambda^L$ :

$$\begin{array}{ccc}
(\alpha(\lambda x Z_1(x))) Z_2 & \longrightarrow & -\alpha Z_1(-\alpha Z_2) \\
||| \text{ (notation)} & & ||| \text{ (notation)} \\
(\lambda x Z_1(x))^\alpha Z_2 & \longrightarrow & Z_1^\alpha(Z_2^\alpha)
\end{array}$$

for all  $\alpha \in L$  as defined in I.3.9. So the  $\alpha \in L$  and "-" are constants of the CRS  $\lambda^L$ .

### 3. THE CHURCH-ROSSER THEOREM FOR REGULAR COMBINATORY REDUCTIONS

One of our aims in the next sections of this chapter is to prove for regular CRS's  $\Sigma$  that

- (1)  $\Sigma \models \text{FD}$ , i.e.  $\underline{\Sigma} \models \text{SN}$  (Finite Developments)
- (2)  $\Sigma \models \text{CR}^+$ , i.e. the strong version of the Church-Rosser theorem, analogous to Theorem I.6.9 for definable extensions of  $\lambda\beta$ .

For  $\lambda(a)$ -reductions, a proof of (1), (2) is given by HINDLEY [78], for TRS's by LÉVY-HUET [79]. ACZEL [78] proves CR (not  $\text{CR}^+$ ) for his contraction schemes by a method analogous to that in the well-known proof of  $\lambda\beta \models \text{CR}$  of Tait and Martin-Löf, see e.g. BARENDREGT [80] or [77].

In the proof of (1), (2) for all regular CRS's we have the problem that the two methods used in Chapter I to prove  $\lambda\beta \models \text{FD}$  are not of much help here: Micali's proof (Lemma I.4.3.3) based on the disjointness property of  $\lambda\beta$ -developments does not work here since DP does not hold for all regular CRS's, see Remark 2.13.(i); the proof using 'decreasing weights' as in I.4.1 might be extended to the present case, but such an extension seems very complicated.

Therefore we will split the problem to prove FD, and hence  $\text{CR}^+$ , into two parts: reduction in a CRS can be analyzed into

- (a) a 'Term Rewriting part' where subterms are manipulated (multiplied, erased, permuted) as in a TRS, and
- (b) a 'substitution part', as in  $\lambda\beta$ -calculus.

To do that, we introduce for each CRS  $\Sigma$  a CRS  $\Sigma_f$  (where the substitution part is suspended or 'frozen') and a CRS  $\Sigma_{f\beta}$ , as follows.

3.1. DEFINITION. To each regular CRS  $\Sigma$  we assign a CRS  $\Sigma_f$  as follows.

- (i) The alphabet of  $\Sigma_f = \text{alphabet of } \Sigma \cup \{\lambda, -\}$ .
- (ii) The map  $f_0: \text{Mter}(\Sigma) \rightarrow \text{Mter}(\Sigma_f)$  is defined by



$$f_0(x) = x, \quad f_0(Q) = Q$$

$$f_0([x]A) = [x]f_0(A)$$

$$f_0(AB) = f_0(A)f_0(B)$$

$$f_0(Z(H_1, \dots, H_k)) = \underline{(\lambda x_1 \dots x_k . Z(x_1, \dots, x_k))} f_0(H_1) \dots f_0(H_k).$$

(iii)  $f_1: \text{Red}(\Sigma) \longrightarrow \text{Red}(\Sigma_f)$  is the map assigning to  $r = H \rightarrow E'$  the rule

$$f_1(r) = H \rightarrow f_0(H').$$

(iv)  $\text{Red}(\Sigma_f) = \{f_1(r) \mid r \in \text{Red}(\Sigma)\}.$

3.2. DEFINITION.  $\Sigma_{f\beta}$  has the same alphabet and rules as  $\Sigma_f$  plus as extra rules  $\beta_k$ -reduction for all  $k \geq 1$ :

$$\beta_k = \underline{(\lambda x_1 \dots x_k . Z_0(x_1, \dots, x_k))} Z_1 Z_2 \dots Z_k \longrightarrow Z_0(Z_1, \dots, Z_k)$$

$\beta_m$  (m for 'many') will denote the union of the  $\beta_k$ -reductions ( $k \geq 1$ ), as in Def.I.4.2.2.

3.3. REMARK. (i)  $\Sigma_f$  and  $\Sigma_{f\beta}$  are evidently again regular CRS's, since the LHS's of the rules are unaltered.

(ii) Obviously, if in  $\Sigma: A \xrightarrow{r} B$ , then in  $\Sigma_{f\beta}: A \xrightarrow{f_1(r)} \xrightarrow{\beta_m} B$ . So in  $\Sigma_{f\beta}$  the  $\Sigma$ -reductions are separated into a 'term rewriting part'  $f_1(r)$  and a 'substitution part'  $\beta_m$ .

(iii) Note that  $\Sigma_f$  is in fact a TRS, by considering the variables  $x, y, \dots$ , which do not play that role in  $\Sigma_f$  anymore, as new constants. (This remark is meant heuristically and we will not prove it.)

3.4. EXAMPLE. (i) 'Frozen'  $\lambda\beta$ -calculus,  $(\lambda\beta)_f$ , has as only rule (writing  $\lambda x$  for  $\lambda[x]$  in the LHS):

$$f_1(\beta) = (\lambda x . Z_1(x)) Z_2 \longrightarrow (\underline{\lambda x} . Z_1(x)) Z_2$$

(ii) If  $\Sigma$  is a TRS, then  $\Sigma_f = \Sigma$ .

3.5. DEFINITION. Let  $\Sigma$  be a regular CRS. Then  $\Sigma \models \text{WCR}^+$  iff

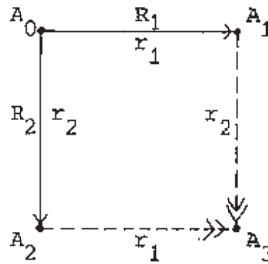

i.e. for all  $\Sigma$ -terms  $A_0, A_1, A_2$  such that  $A_0 \rightarrow A_i$  by contraction of an  $r_i$ -redex  $R_i$  ( $i = 1, 2$ ), there is a common reduct  $A_3$ , to be found by a complete  $r_i$ -development of the set  $S_i$  of residuals in  $A_i$  of  $R_i$  ( $i = 1, 2$ ).

(Remark: We do not yet know that all developments of the sets  $S_i$  ( $i = 1, 2$ ) are finite, nor that all complete developments end in the same term. At this stage, we do not know even that there is a complete development of  $S_i$ . Later on, in Lemma 3.9 and Theorem 4.15, all this will be proved to hold indeed.)

Checking that  $\Sigma \models WCR^+$  (for  $\Sigma$  regular) is no longer as trivial as for  $\lambda\beta$ -calculus, due to the possibly complicated substituting behaviour of CRS's. Therefore first:

3.6. LEMMA. Let  $\Sigma$  be a regular CRS. Then  $\Sigma_{f\beta} \models WCR^+$ .

PROOF. This requires a consideration of the following cases:

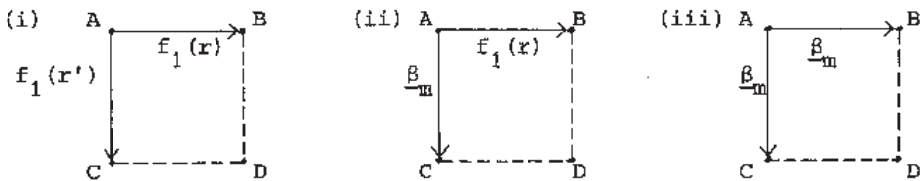

and checking that indeed the common reduct  $D$  can be found by reduction of residuals of the redexes in question, as required by the property  $WCR^+$ . This is just as easy as checking that  $\lambda\beta_m \models WCR^+$  and that every TRS  $\models WCR^+$  (in fact for that reason  $\Sigma_{f\beta}$  was introduced), and we omit the actual verification.  $\square$

With the aid of the concept  $\Sigma_{f\beta}$  we will now first prove a weak form of FD for regular CRS's  $\Sigma$  (namely that  $\Sigma \models WN$ ) and get CR as a corollary.

After introducing some more theory (the elaboration of a method originally due to NEDERPELT [73]) this is used to get the full FD and CR<sup>+</sup> theorem.

In the next few pages we will prove to that end some technical (but intuitively clear) propositions; the main activity thereby is 'label tracing'. We will allow ourselves a bit of informality in the description of this activity (in the same spirit as when one speaks of 'diagram chasing' in e.g. category theory), since a more formal treatment would probably not be more perspicuous.

The next Proposition prepares the way for the main Proposition 3.8.

3.7. PROPOSITION.  $\Sigma_{f\beta} \models \text{FD}$ . I.e. every  $\Sigma_{f\beta}$ -development terminates.

PROOF. Let  $M \in \text{Ter}(\Sigma_{f\beta})$  and let an underlining of the headsymbol of some set  $\mathcal{R}$  of redexes in  $M$  be given. Furthermore, let  $\mathcal{R}$  be a reduction of  $M$  in which only underlined redexes are contracted. We have to prove that  $\mathcal{R}$  is finite.

The proof is a straightforward extension of the proof of Theorems I.4.1.11 and I.4.2.5, using the method of 'decreasing weights', and will therefore be omitted.  $\square$

3.7.1. EXAMPLE. Let  $\Sigma$  have as only rule

$$(\underline{Q}x.z_1(x)) (\underline{Q}y.z_2(y)) \longrightarrow z_2(z_1(\underline{Q}y.z_2(y))).$$

Then  $\Sigma_{f\beta}$  has the two rules

$$(\underline{Q}x.z_1(x)) (\underline{Q}y.z_2(y)) \longrightarrow (\underline{\lambda}a.z_2(a)) [(\underline{\lambda}x.z_1(x)) (\underline{Q}y.(\underline{\lambda}y'.z_2(y'))y)]$$

$$\beta_1 = (\underline{\lambda}x.z_1(x)) z_2 \longrightarrow z_1(z_2).$$

Now in  $\Sigma$  every reduction starting with  $(\underline{Q}x.xx) (\underline{Q}y.yyy)$  is infinite; in  $\Sigma_{f\beta}$  we have the terminating reduction:

$$(\underline{Q}x.xx) (\underline{Q}y.yyy) \longrightarrow (\underline{\lambda}a.aaa) [(\underline{\lambda}x.xx) (\underline{Q}y.(\underline{\lambda}y'.y'y'y')y)]$$

$$\longrightarrow MM(MM) (MM) \quad (\text{where } M \equiv \underline{Q}y.yyy),$$

a  $\Sigma_{f\beta}$ -normal form.

The 'main proposition' says nothing more than that a 'separated' complete development  $\mathcal{R}$  of a set of redexes in a  $\Sigma$ -term  $M$ , where 'separated' means that  $\mathcal{R}$  takes place via  $\Sigma_{f\beta}$ , can be replaced by a complete development  $\mathcal{R}'$  in  $\Sigma$  of the same set of redexes.

### 3.8. PROPOSITION.

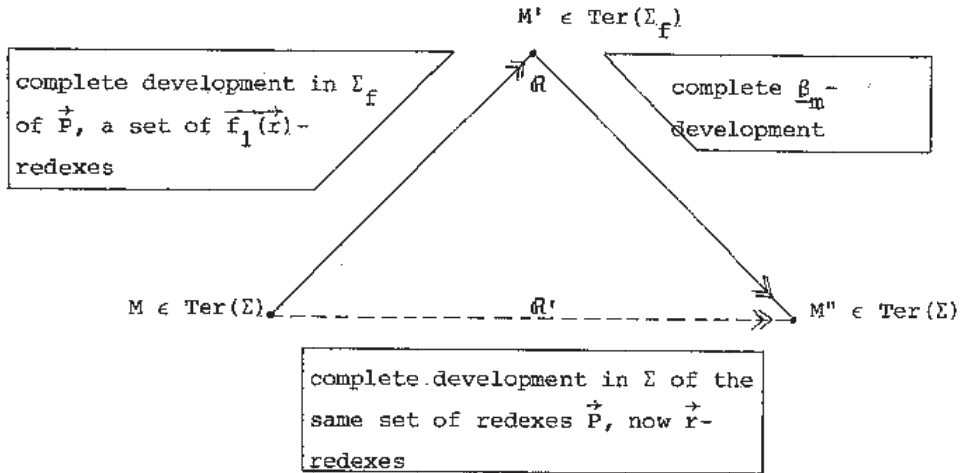

Let  $M$  be a  $\Sigma$ -term, and  $P_1, \dots, P_n$  be a set of resp.  $r_1, \dots, r_n$ -redexes in  $M$  with  $r_1, \dots, r_n \in \text{Red}(\Sigma)$ . Since  $\text{Ter}(\Sigma) \subseteq \text{Ter}(\Sigma_f)$ ,  $M$  is also a  $\Sigma_f$ -term; and  $P_1, \dots, P_n$  are resp.  $f_1(r_1), \dots, f_1(r_n)$ -redexes in  $\Sigma_f$ .

Now let  $M' \in \text{Ter}(\Sigma_f)$  be the result of a complete development (c.dev.) of the  $f_1(r)$ -redexes  $\vec{P}$ , and let  $M''$  be the complete  $\beta_m$ -development (in  $\Sigma_{f\beta}$ ) of all the  $\vec{x}$ -redexes which have originated by the c.dev.  $M \rightarrow M'$ . So  $M'' \in \text{Ter}(\Sigma)$ .

Then there is a c.dev. in  $\Sigma$  from  $M$  to  $M''$  of the  $\vec{r}$ -redexes  $\vec{P}$ . (See figure above.)

PROOF. The proof is in five parts.

(1) In case  $n = 1$  (in  $\vec{P} = P_1, \dots, P_n$ ) the proposition follows immediately from the definitions of  $\Sigma_f$  and  $\Sigma_{f\beta}$ . In the case that the  $P_i$ -redexes are disjoint, the proposition follows also immediately by the previous statement.

(2) *Reminder:*  $\beta_m$ -developments have the *disjointness property*. (Corollary I.4.3.10) i.e. if  $M \beta_m$ -develops to  $M'$ , then the residuals in  $M'$  of a subterm  $N \subseteq M$  are pairwise disjoint.

(3)

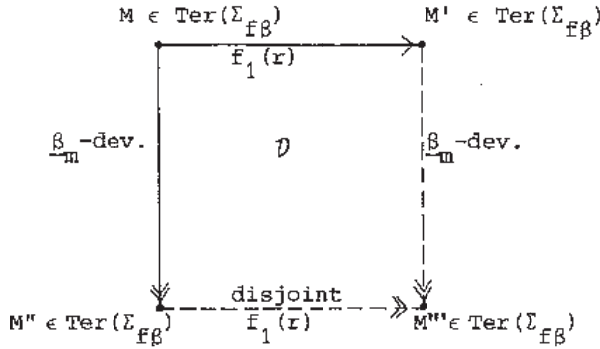

CLAIM. Let  $M \in \text{Ter}(\Sigma_{f\beta})$  and  $M'$  be the result of an  $f_1(r)$ -contraction,  $M''$  of a  $\beta_m$ -development (not necessarily complete). Then a common reduct  $M'''$  is found by a  $\beta_m$ -development of  $M'$  and a development of the (by (2) disjoint)  $f_1(r)$ -redexes which are the residuals of the contracted  $f_1(r)$ -redex in  $M$ . (See figure above.)

PROOF OF THE CLAIM. In Lemma 3.6, we proved that  $\Sigma_{f\beta} \models \text{WCR}^+$ . So, we can try a successive addition of the elementary diagrams (e.d.'s) shown in the proof of Lemma 3.6, like in the proof of  $\text{CR}^+$  in I.6.1, to find a common reduct. That the thus obtained reduction diagram  $\mathcal{D}$  'closes' indeed, follows from the fact that  $\Sigma_{f\beta} \models \text{FD}$  (Proposition 3.7) considering that all the reductions in  $\mathcal{D}$  are  $f_1(r)$ - and  $\beta_m$ -developments.

Finally, by the construction of  $\mathcal{D}$  and properties of the e.d.'s it is obvious that the  $f_1(r)$ -development  $M'' \twoheadrightarrow M'''$  thus obtained is a development of residuals of the original  $f_1(r)$ -redex in  $M$ .

(4)

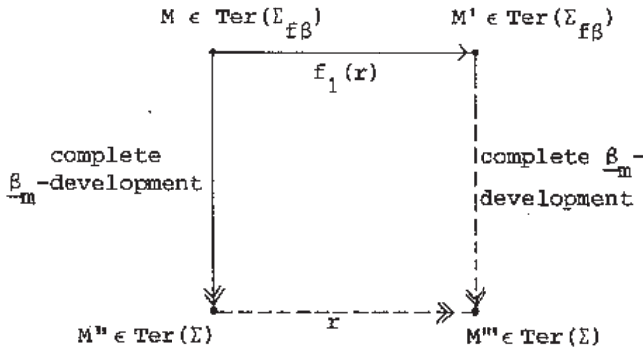

CLAIM. Given  $M, M', M''$  as in the figure, there is a common reduct  $M''' \in \text{Ter}(\Sigma)$  which is the complete  $\beta_m$ -development of  $M'$  and which is obtained from

$M'' \in \text{Ter}(\Sigma)$  by a complete development of the  $r$ -redexes which are the residuals of the original  $f_1(r)$ -redex in  $M$ .

PROOF OF THE CLAIM. By (3), (1) and the following figure:

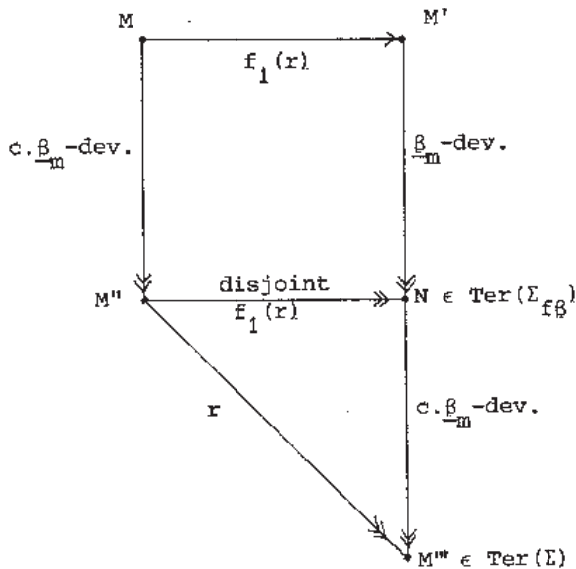

(5) Finally we can prove the proposition. Let  $M \in \text{Ter}(\Sigma)$ ,  $M' \in \text{Ter}(\Sigma_{f\beta})$  and  $M'' \in \text{Ter}(\Sigma)$  be given as in the statement to prove:

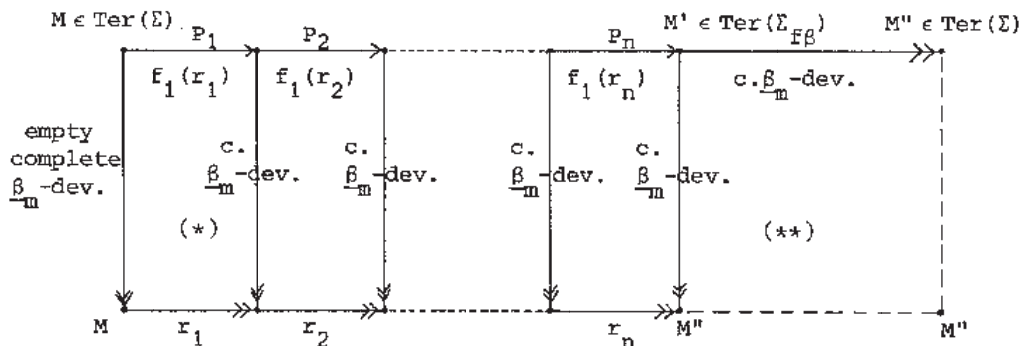

Then repeated application of (4) yields the proposition, using (ad $(*)$ ) in the figure above) that the complete  $\beta_m$ -development of  $M \in \text{Ter}(\Sigma)$  is the empty reduction (since  $M$  does not contain  $\underline{\lambda x}$ ) and (ad $(**)$ ) in the figure

above) that the result of a complete  $\beta_m$ -development is unique.  $\square$

3.9. COROLLARY.  $\Sigma \models \text{WN}$ .

*I.e. for every  $\Sigma$ , the corresponding underlined  $\Sigma$  satisfies Weak Normalization. Or in other words: for every  $\Sigma$ -term  $M$  there is a terminating complete development of a given set of redexes in  $M$ .*

PROOF. Let  $M \in \text{Ter}(\Sigma)$  and let  $\mathcal{R}$  be a set of redexes in  $M$  specified by underlining their head symbol. (So  $(M, \mathcal{R}) \in \text{Ter}(\underline{\Sigma})$ .) Now working in  $\Sigma_{f\beta}$ , take a complete development  $M \rightarrow M' \in \text{Ter}(\Sigma_{f\beta})$ , and next the complete  $\beta_m$ -development of  $M'$ :

$$M \in \text{Ter}(\Sigma) \longrightarrow M' \in \text{Ter}(\Sigma_{f\beta}) \xrightarrow{\text{c. } \beta_m\text{-dev.}} M'' \in \text{Ter}(\Sigma).$$

Then apply the proposition above to get a complete development  $M \rightarrow M''$  now taking place in  $\Sigma$ .  $\square$

3.10. LEMMA. Let  $\Sigma$  be a regular CRS. Then  $\Sigma \models \text{WCR}^+$ .

PROOF. (1) Let reductions  $A_0 \rightarrow A_i$  ( $i = 1, 2$ ) as in Definition 3.5 of  $\text{WCR}^+$  be given.

(2) Perform the same steps but now 'separated', i.e. via  $\Sigma_{f\beta}$ .

(3) Complete the reduction diagrams  $\mathcal{D}_0, \mathcal{D}_1, \mathcal{D}_2, \mathcal{D}_3$  as in the figure below. That these completions are indeed possible, is easily checked by some routine arguments. (See figure on p.149.)

Here  $\mathcal{R}'_2$  is the set of  $f_1(r_2)$ -residuals of the  $f_1(r_2)$ -redex  $R_2$  in  $A_0$ ;  $\mathcal{R}''_2$  the set of  $f_1(r_2)$ -residuals of the redexes in  $\mathcal{R}'_2$ , etc.

By a label-tracing argument (color the original redexes  $R_1, R_2$  red resp. blue and correspondingly the  $\lambda x^+$ 's originating from them; so we have red and blue  $\beta_m$ -developments; since  $A_1$  contains no red and  $A_2$  no blue,  $A_3$  is colorless) it is obvious that  $A_3 \in \text{Ter}(\Sigma)$ .

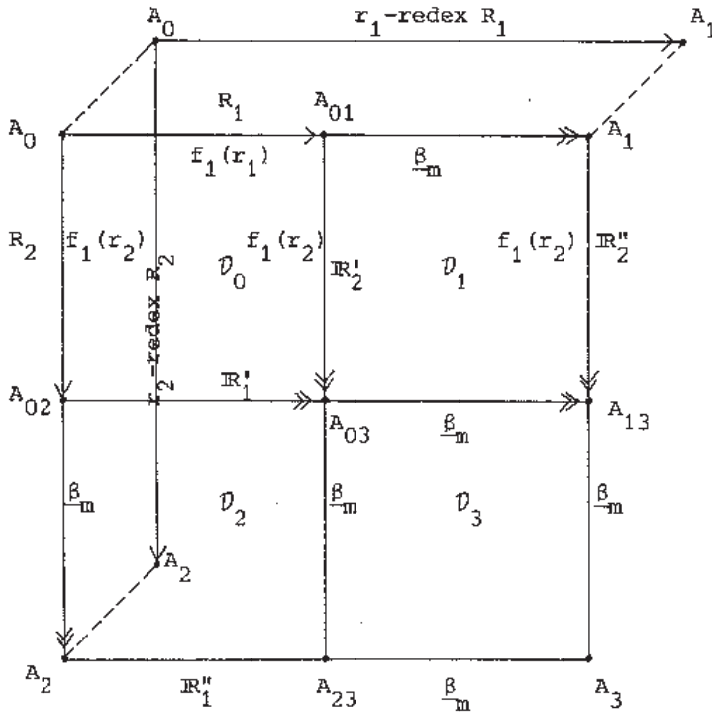

Finally, using Proposition 3.8 yields complete developments as required:

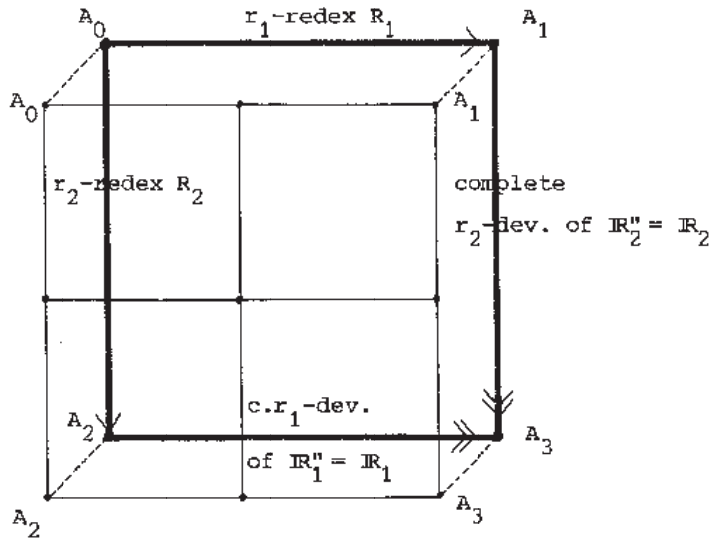

where it is routine to check that  $IR''_1$ , as defined above, equals  $IR_1$ , the set of residuals of  $R_1$  after contraction of  $R_2$ , and likewise with 1,2 interchanged.  $\square$



3.11. THEOREM.  $\Sigma \models \text{CR}$ ; for every regular CRS  $\Sigma$ .

PROOF. Let  $\Sigma$ -reductions  $R_1 = M_0 \rightarrow M_1 \rightarrow \dots \rightarrow M_n$  and  $R_2 = M'_0 \rightarrow M'_1 \rightarrow M'_2 \rightarrow \dots \rightarrow M'_n$  be given. Using the same argument as in the proof of the preceding Lemma, we can now 'fill in' block-by-block of the following two-layered reduction diagram,  $\mathcal{D}_\Sigma$  behind and  $\mathcal{D}_{\Sigma_{f\beta}}$  in front:

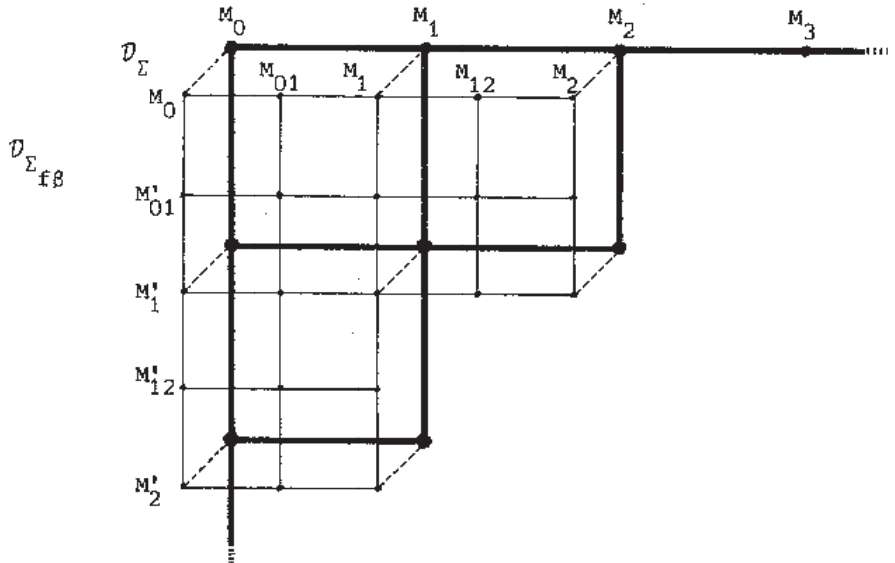

Note that after having 'lifted' the edge  $M_0 \rightarrow M_1 \rightarrow \dots$  of  $\mathcal{D}_\Sigma$  to the edge  $M_0 \rightarrow M_{01} \rightarrow M_1 \rightarrow M_{12} \rightarrow \dots$  of the auxiliary diagram  $\mathcal{D}_{\Sigma_{f\beta}}$ , the construction of  $\mathcal{D}_\Sigma$  follows by a projection (using Proposition 3.8) of the construction of  $\mathcal{D}_{\Sigma_{f\beta}}$ , as in the proof of the preceding Lemma.

□

3.12. REMARK. The status of several analogues to the case of  $\lambda\beta$ -calculus in Ch.I is not yet clear, namely:

- (1) FD; if  $M \in \text{Ter}(\Sigma)$ , then all developments of the underlined term  $(M, \underline{IR}) \in \text{Ter}(\Sigma)$  terminate.

(2) The Parallel Moves Lemma (cf. I.6.12).

(3)  $CR^+$ ; the 'stepwise' diagram construction by adjunction of e.d.'s terminates.

In fact it is sufficient to prove FD; for then PM and  $CR^+$  are corollaries. That FD holds for  $\Sigma$ , i.e.  $\Sigma \vdash SN$ , will be a corollary of a general method to reduce SN-proofs to WN-proofs. This will be the next subject.

#### 4. REDUCTIONS WITH MEMORY

The difference between  $\lambda$ -calculus and  $\lambda I$ -calculus is that in the former subterms can be erased. This is the reason that some pleasant properties of the  $\lambda I$ -calculus fail for  $\lambda$ -calculus; see I.7. We will now associate to each regular CRS  $\Sigma$  a regular CRS  $\Sigma_{[ , ]}$  in which there is no erasure. This will lead to a method to reduce SN-proofs to WN-proofs, described in the next section; corollaries are the theorems FD,  $CR^+$ , PM for regular CRS's  $\Sigma$ .

4.1. DEFINITION. Let  $Q = \{Q_i \mid i \in I\}$  be the set of constants of  $\Sigma$ . Then the set of constants of  $\Sigma_{[ , ]} = Q \cup \{Q_i^* \mid i \in I\} \cup \{P\}$ .

4.2. NOTATION. (i) Instead of PAB we write  $[A, B]$ . The subterm B is called the *memory part* of  $[A, B]$ .

(ii)  $[A, B_1, \dots, B_{n+1}] := [[A, B_1, \dots, B_n], B_{n+1}]$

(iii) If  $\vec{B} = B_1, \dots, B_n$  we will sometimes write  $A_{\vec{B}}$  for  $[A, \vec{B}]$ , when it is typographically more convenient; we will even employ both notations simultaneously in one term, as e.g. in  $[A, B_C]$ .

(iv) If  $H \in \text{Mter}(\Sigma)$ , then  ${}^*H \in \text{Mter}(\Sigma_{[ , ]})$  is the result of replacing H's head symbol  $Q$  by  $Q^*$ .

4.3. INTUITION. To motivate the next definition, consider the TRS:  $\Sigma = CL \oplus \text{Pairing}$ , with constants  $I, K, S, \mathcal{D}, \mathcal{D}_0, \mathcal{D}_1$  and rules:

$$IZ \longrightarrow z, Kz_1z_2 \longrightarrow z_1, Sz_1z_2z_3 \longrightarrow z_1z_3(z_2z_3),$$

$$\mathcal{D}_0(\mathcal{D}z_1z_2) \longrightarrow z_1, \mathcal{D}_1(\mathcal{D}z_1z_2) \longrightarrow z_2.$$

Obviously there is erasure here: in the rules for  $K$  and  $\mathcal{D}_0, \mathcal{D}_1$ .

(i) We want to eliminate this erasure in  $\Sigma_{[ , ]}$  by replacing the  $K$ -rule by

$$KZ_1Z_2 \longrightarrow [Z_1, K^*Z_1Z_2],$$

the  $\mathcal{D}_0$ -rule by

$$\mathcal{D}_0(\mathcal{D}Z_1Z_2) \longrightarrow [Z_1, \mathcal{D}_0^*(\mathcal{D}Z_1Z_2)],$$

etc. I.e. the original redex is repeated as 'memory part', but 'frozen' by \*. (But note that the redexes possibly occurring in the subterms substituted for the meta-variables  $Z_i$ , e.g. in  $K^*Z_1Z_2$  above, are not affected by \*.) Obviously, the resulting rules are non-erasing. Even the non-erasing rules will be transformed in this way, so the I-rule in  $\Sigma$  becomes in  $\Sigma_{[ , ]}$ :

$$IZ \longrightarrow [Z, I^*Z].$$

(This is done not only for the sake of an uniform description, but also to make  $\Sigma_{[ , ]}$  increasing; see Prop.4.9 below.)

(ii) Further, we want to be able to imitate each reduction  $\mathcal{R}$  in  $\Sigma$  by the 'same' reduction  $\mathcal{R}'$  in  $\Sigma_{[ , ]}$  (necessary in the proof of Lemma 4.10); that is, if in  $\mathcal{R}'$  the memorized parts are erased, the result is  $\mathcal{R}$ . To be able to do this, we introduce in  $\Sigma_{[ , ]}$  the 'shift rule'

$$[Z_1, Z_2]Z_2 \longrightarrow [Z_1, Z_3, Z_2]$$

which gives the reductions  $A_B \overset{\rightarrow}{\rightarrow} (AC) \overset{\rightarrow}{\rightarrow}_B$ ; this was also done in I.8.5. Now consider e.g. the following  $\mathcal{R}$  in  $\Sigma$ :

$$K\mathcal{D}_0C(\mathcal{D}AB) \longrightarrow \mathcal{D}_0(\mathcal{D}AB) \longrightarrow A.$$

Then  $\mathcal{R}$  will give rise to the following imitation  $\mathcal{R}'$  in  $\Sigma_{[ , ]}$  (by way of illustration we employ the  $[ , ]$  - as well as the subscript notation):

$$\begin{aligned} K\mathcal{D}_0C(\mathcal{D}AB) &\longrightarrow \\ [\mathcal{D}_0, K^*\mathcal{D}_0C](\mathcal{D}AB) &\equiv \mathcal{D}_0 K^*\mathcal{D}_0C(\mathcal{D}AB) \xrightarrow{\text{shift}} \\ [\mathcal{D}_0(\mathcal{D}AB), K^*\mathcal{D}_0C] &\equiv (\mathcal{D}_0(\mathcal{D}AB)) K^*\mathcal{D}_0C \xrightarrow{\quad} \\ [[A, \mathcal{D}_0^*(\mathcal{D}AB)], K^*\mathcal{D}_0C] &\equiv A_{\mathcal{D}_0^*}(\mathcal{D}AB), K^*\mathcal{D}_0C \end{aligned}$$

Note how in the shift step the memorized subterm  $K^*\mathcal{D}_0C$ , which is affixed to the head symbol  $\mathcal{D}_0$  of the redex  $\mathcal{D}_0(\mathcal{D}AB)$ , is shifted 'out of' that redex.

(iii) But this is not yet enough, because memorized parts affixed to 'deeper' subterms in a redex cannot be shifted out of the redex. For, in order to imitate the following reduction  $\mathcal{R}$  in  $\Sigma$ :

$$\mathcal{D}_0(KDCAB) \longrightarrow$$

$$\mathcal{D}_0(KDCAB) \longrightarrow$$

$$\mathcal{D}_0(DAB) \longrightarrow$$

A

by the reduction  $\mathcal{R}'$  in  $\Sigma_{[\cdot, \cdot]}$ :

$$\mathcal{D}_0(KDCAB) \longrightarrow$$

$$\mathcal{D}_0([K, I^*K]DCAB) \xrightarrow{\text{shift}} \longrightarrow$$

$$\mathcal{D}_0([KDCAB, I^*K]) \longrightarrow$$

$$\mathcal{D}_0([[D, K^*DC]_{AB}, I^*K]) \xrightarrow{\text{shift}} \longrightarrow$$

$$\mathcal{D}_0([[DAB, K^*DC], I^*K]) \equiv \mathcal{D}_0(DAB)_{K^*DC, I^*K} \longrightarrow$$

$$[A, \mathcal{D}_0(DAB)_{K^*DC, I^*K}]$$

we need the rule (for the last step in  $\mathcal{R}'$ ):

$$\mathcal{D}_0(\mathcal{D}z_1 z_2)_{z_3, z_4} \longrightarrow [z_1, \mathcal{D}_0(\mathcal{D}z_1 z_2)_{z_3, z_4}]$$

(Note: one should not confuse  $\mathcal{D}_0(DAB)_{\dot{C}}$  and  $(\mathcal{D}_0(DAB))_{\dot{C}}$ .)

This motivates the next definition:

4.4. DEFINITION. (i) On  $\text{Mter}(\Sigma_{[\cdot, \cdot]})$  we define the 'forgetful' reduction rule (as in Def.I.8.6):

$$k = [z_1, z_2] \longrightarrow z_1.$$

If  $A, B \in \text{Mter}(\Sigma_{[\cdot, \cdot]})$  and  $A \xrightarrow{k} B$ , then A is a 'k-expansion' of B.

So e.g.  $H \equiv (A_{D,E} (B_{F,C} G_{H,I})_{J,K})$  is a k-expansion of  $(A_E (BC)_H)_J$ , which is a k-expansion of the k-normal form  $A(BC)$ . Moreover, we will say that in H the subterm A is k-expanded, and likewise the subterms B,  $B_{\dot{F}C}$  and  $A_{D,E} (B_{\dot{F}C})_{G,H,I}$ .

(ii) Further, we define on  $\text{Mter}(\Sigma_{[, ]})$  the rule

$$\text{shift} = [Z_1, Z_2]Z_3 \longrightarrow [Z_1Z_3, Z_2].$$

So a 'shift-normal form'  $H' \in \text{Mter}(\Sigma_{[, ]})$  is a term  $H$  in which all the memory parts are shifted to the right as far as possible. E.g.  $H$  in (i) is not in shift-n.f., but  $H \xrightarrow{\text{shift}} (A(BC)_{F,G,H,I})_{D,E,J,K} \equiv H'$  which is in shift-n.f (if  $A, B, C$  are).

4.5. DEFINITION of  $\text{Red}(\Sigma_{[, ]})$ .

(i) Let  $r = H_1 \longrightarrow H_2 \in \text{Red}(\Sigma)$ . Then  $r_{[, ]}$  is the set of rules of the form

$$H'_1 \longrightarrow [H_2, {}^*(H'_1)]$$

where  $H'_1$  is a  $k$ -expansion of  $H_1$  such that:

- (1)  $H'_1$  is *linear* (i.e. no meta-variable occurs twice in  $H'_1$ )
- (2)  $H'_1$  is in *shift-normal form*
- (3)  $H'_1$  is not of the form  $[H, \vec{Z}]$ , or equivalently,  $H'_1$  and  $H_1$  have the same head symbol  $Q$
- (4) the meta-variables in  $H'_1$  are not  $k$ -expanded.

Requirements (3) and (4) are merely technical; a motivation will follow soon (in 4.6.(4)).

(ii) Now we can define

$$\text{Red}(\Sigma_{[, ]}) = \bigcup_{r \in \text{Red}(\Sigma)} r_{[, ]} \cup \{\text{shift}\}.$$

4.6. EXAMPLES AND REMARKS.

(1) Let  $r = H_1 \longrightarrow H_2 = R\underline{O}Z_1Z_2 \longrightarrow Z_1$  be a rule in  $\text{Red}(\Sigma)$ . Then all the rules

$$H'_1 \equiv R[\underline{O}, \vec{Z}_0]Z_1Z_2 \rightarrow [Z_1, R^*[\underline{O}, \vec{Z}_0]Z_1Z_2]$$

will be in  $\text{Red}(\Sigma_{[, ]})$ , where  $\vec{Z}_0 = Z_{01} \dots Z_{0m}$  ( $m \geq 0$ ),  $Z_1, Z_2$  are pairwise distinct.

(2) Let  $\Sigma$  be CL  $\otimes$  Pairing, as in 4.3. Then we have in  $\Sigma_{[, ]}$  the rules (among others):

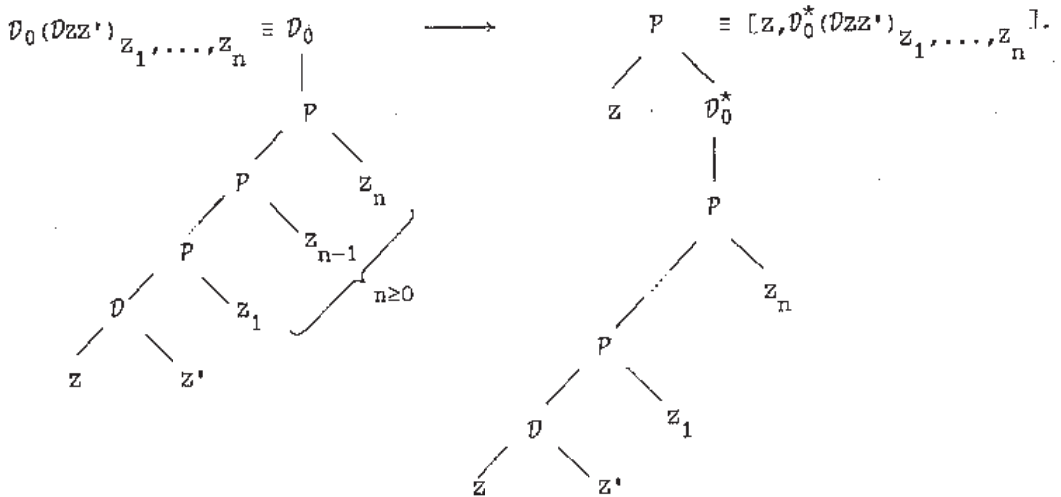

(3) Let  $\Sigma = \lambda\beta$ -calculus). Then  $(\lambda\beta)_{[\cdot, \cdot]}$  has besides 'shift' as only rule:

$$\beta_{[\cdot, \cdot]} = (\lambda x. Z_1(x)) Z_2 \longrightarrow [Z_1(Z_2), (\lambda^* x. Z_1(x)) Z_2]$$

where  $\lambda x. Z_1(x)$  is written for  $\lambda([x]Z_1(x))$  (In fact this is not quite true: due to our inductive definition of  $\text{Ter}(\Sigma)$ , in this case also  $\lambda$  and  $[x]Z_1(x)$  are subterms of  $\lambda([x]Z_1(x))$ . Hence we should have in  $(\lambda\beta)_{[\cdot, \cdot]}$  also a rule  $r' = \lambda([x]Z_1(x)) \xrightarrow{Z_2} [Z_1(Z_2), \dots]$ . But the definition of  $\text{Ter}(\Sigma)$  can be easily adapted such that it conforms to the usual one for  $\lambda\beta$ -terms, thus excluding the unnecessary rule  $r'$ .)

(4) Given a rule, say,  $r = KZ_1 Z_2 \longrightarrow Z_1$  in  $\Sigma$ , there is no need to include in  $\text{Red}(\Sigma_{[\cdot, \cdot]})$  rules where the meta-variables are expanded:

$K[Z_1, \vec{Z}][Z_2, \vec{Z}'] \longrightarrow [Z_1, \dots]$  since in  $\Sigma_{[\cdot, \cdot]}$  the meta-variables  $Z_1, Z_2$  in  $KZ_1 Z_2 \longrightarrow [Z_1, K^* Z_1 Z_2]$  range already over terms of the form  $[A, \vec{B}]$ .

Also there is no need to include the rule  $[KZ_1 Z_2, \vec{Z}] \longrightarrow [Z_1, \dots]$  since the LHS is merely a context of  $KZ_1 Z_2$ .

**4.7. PROPOSITION.** Let  $\Sigma$  be a regular CRS. Then  $\text{Red}(\Sigma_{[\cdot, \cdot]})$  is left-linear and non-ambiguous; hence  $\Sigma_{[\cdot, \cdot]}$  is a regular CRS.

**PROOF.** The left-linearity was explicitly required in the definition. As to the non-ambiguity, it is not hard to show that a supposed ambiguity in  $\text{Red}(\Sigma_{[\cdot, \cdot]})$  would yield one in  $\text{Red}(\Sigma)$  after erasing all the memory parts in the pair of interfering rules.

(Note that the 'forgetful' rule  $k \nmid \text{Red}(\Sigma_{[ , ]})$ ; otherwise we would have ambiguity, since e.g.  $k$  and 'shift' interfere.)  $\square$

4.8. PROPOSITION. The operations 'addition of underlining':  $\Sigma \mapsto \underline{\Sigma}$  and 'addition of memory':  $\Sigma \mapsto \Sigma_{[ , ]}$  commute. I.e. for every regular CRS  $\Sigma$ :

$$\underline{\Sigma}_{[ , ]} = \underline{\Sigma_{[ , ]}}.$$

PROOF. We will give the proof by considering a typical example. Let  $\Sigma$  be  $\lambda\beta$ -calculus + constants 0 (zero), S (successor) and J (iterator).

So

$$\begin{aligned} \text{Red}(\Sigma) &= \begin{cases} (\lambda x.z_1(x))z_2 \longrightarrow z_1(z_2) \\ J0z_1z_2 \longrightarrow z_2 \\ J(Sz_0)z_1z_2 \longrightarrow z_1(Jz_0z_1z_2) \end{cases} \\ \text{Red}(\underline{\Sigma}) &= \begin{cases} (\lambda x.z_1(x))z_2 \longrightarrow z_1(z_2) \\ \underline{J}0z_1z_2 \longrightarrow z_2 \\ \underline{J}(Sz_0)z_1z_2 \longrightarrow z_1(\underline{J}z_0z_1z_2). \end{cases} \\ \text{Red}(\Sigma_{[ , ]}) &= \begin{cases} (\underline{\lambda}x.z_1(x))z_2 \longrightarrow [z_1(z_2), (\underline{\lambda}^*x.z_1(x))z_2] \\ \underline{J}0z_1z_2 \longrightarrow [z_2, \underline{J}^*0z_1z_2] \\ \underline{J}(Sz_0)z_1z_2 \longrightarrow [z_1(\underline{J}z_0z_1z_2), \underline{J}^*(Sz_0)z_1z_2] \end{cases} \\ \text{Red}(\underline{\Sigma}_{[ , ]}) &= \begin{cases} (\lambda x.z_1(x))z_2 \longrightarrow [z_1(z_2), (\lambda^*x.z_1(x))z_2] \\ \underline{J}0z_1z_2 \longrightarrow [z_2, \underline{J}^*0z_1z_2] \\ \underline{J}(Sz_0)z_1z_2 \longrightarrow [z_1(\underline{J}z_0z_1z_2), \underline{J}^*(Sz_0)z_1z_2] \end{cases} \\ \text{Red}(\Sigma_{[ , ]}) &= \begin{cases} (\underline{\lambda}x.z_1(x))z_2 \longrightarrow [z_1(z_2), (\underline{\lambda}^*x.z_1(x))z_2] \\ \underline{J}0z_1z_2 \longrightarrow [z_2, \underline{J}^*0z_1z_2] \\ \underline{J}(Sz_0)z_1z_2 \longrightarrow [z_1(\underline{J}z_0z_1z_2), \underline{J}^*(Sz_0)z_1z_2] \end{cases} \end{aligned}$$

So we have cheated a little bit in the statement of the proposition: more precisely,  $\underline{\Sigma}_{[ , ]}$  and  $\underline{\Sigma_{[ , ]}}$  are isomorphic, by letting correspond the symbols  $Q^*$  in  $\underline{\Sigma}_{[ , ]}$  to the symbols  $Q^*$  in  $\underline{\Sigma_{[ , ]}}$  ( $Q=\lambda, J$ ).  $\square$

In the sequel, we will refer to the properties 'increasing' ( $\Sigma \models \text{Inc}$ ) and 'inductive' ( $\Sigma \models \text{Ind}$ ), defined in I.5.16.

4.9. PROPOSITION.  $\Sigma_{[ , ]} \models \text{Inc}$ , for all  $\Sigma$ .

PROOF. Let  $|M|$  be the length of a  $\Sigma_{[ , ]}$ -term. Then obviously

$$M \xrightarrow[r]{} N \implies |M| < |N|$$

for all  $r \in \text{Red}(\Sigma_{[ , ]})$ , since the 'old' redex  $R$  is repeated:  
 $M \equiv \mathbb{C}[R] \xrightarrow[r]{} \mathbb{C}[[R', *R]] \equiv N$ . I.e.  $\Sigma_{[ , ]}$  is increasing.  $\square$

4.10. LEMMA.  $\Sigma_{[ , ]} \models \text{SN} \implies \Sigma \models \text{SN}$ .

PROOF. We will not spell out the details, since the situation is very much analogous to that of I.8. Sketch of the proof: suppose  $\Sigma \not\models \text{SN}$ , and let  $\mathcal{R} = M_0 \longrightarrow M_1 \longrightarrow \dots$  be an infinite reduction in  $\Sigma$ . Now it is easy to see that  $\mathcal{R}$  can be mimicked in the following sense:

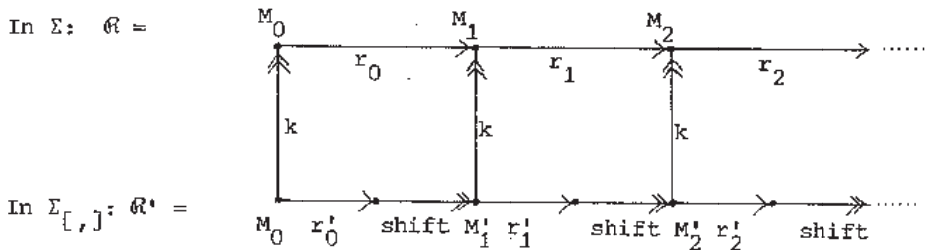

where  $r_i \in \text{Red}(\Sigma)$ ,  $r'_i \in (r_i)_{[ , ]} \subseteq \text{Red}(\Sigma_{[ , ]})$ ,  $i = 0, 1, 2, \dots$ .  $\square$

Now we are ready to prove one of the main theorems of this chapter:

4.11. THEOREM (Generalization of NEDERPELT [73], Thm.3.20).

For all regular CRS's  $\Sigma$ :

$$\Sigma_{[ , ]} \models \text{WN} \implies \Sigma \models \text{SN}.$$



PROOF. *First proof.*

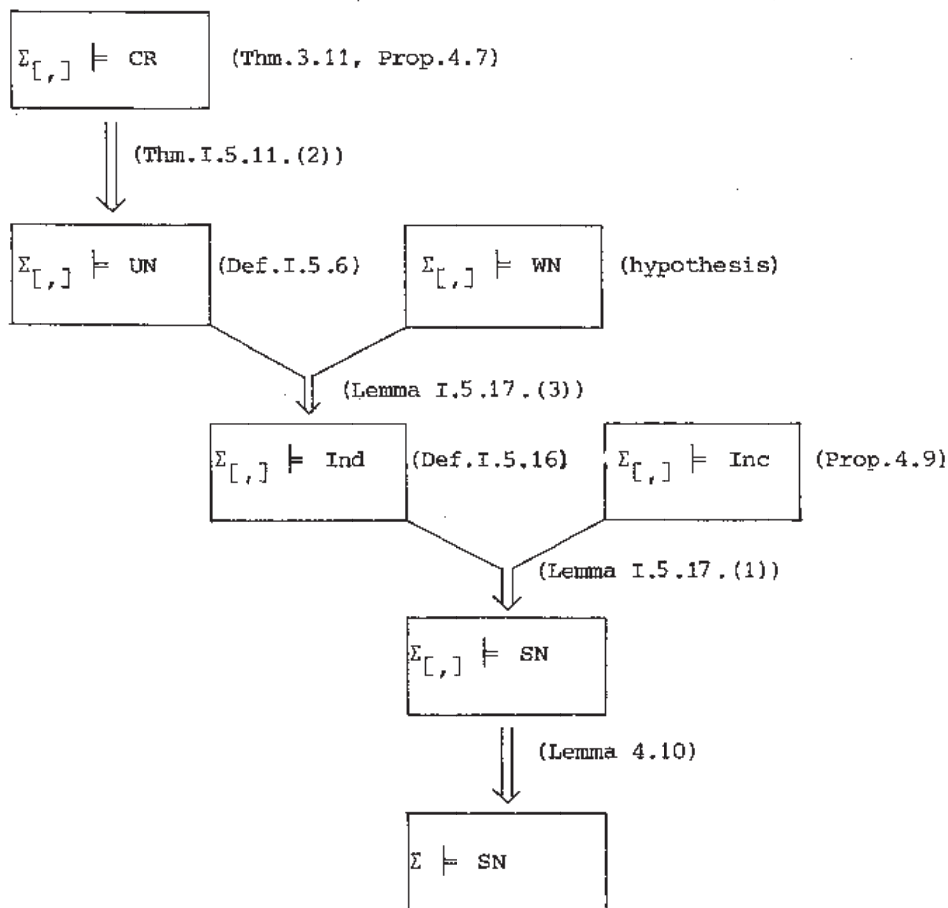

*Alternative proof.*

$$\left. \begin{array}{l}
 \Sigma_{[.,.]} \vdash \text{WCR (Lemma 3.10)} \\
 \Sigma_{[.,.]} \vdash \text{WN (hypothesis)} \\
 \Sigma_{[.,.]} \vdash \text{Inc (Prop.4.9)}
 \end{array} \right\} \xrightarrow{\text{I.5.19.(i)}} \Sigma_{[.,.]} \vdash \text{SN} \xrightarrow{(4.10)} \Sigma \vdash \text{SN}.$$

□

4.12. REMARK. The main idea in this proof is due to NEDERPELT [73], where (essentially) the first proof is given for a special case, namely a 'typed'  $\lambda$ -calculus which arose from the AUTOMATH-project of de Bruijn (Eindhoven).

The properties Inc, Ind are not explicitly mentioned there. Instead of reductions  $r_{[ , ]}$  Nederpelt has ' $\beta_1$ -reduction' (where 'scars' of earlier reductions are retained, as Nederpelt puts it); in our notation (forgetting Nederpelts types) it would read

$$\beta_1 = (\lambda x. Z_1(x))Z_2 \longrightarrow (\lambda x. Z_1(Z_2))Z_2.$$

Nederpelt's ' $\beta_2$ -reduction' corresponds to our k-reduction rule. Where we use as an increasing norm,  $M \mapsto |M|$ , the length of the  $\Sigma_{[ , ]}$ -term M, Nederpelt defines  $|M|$  to be the length of a longest k-reduction path to the k-normal form (obviously k is a strongly normalizing reduction); in our notation we could, equivalently, say:  $|M| :=$  the number of pairs of  $[ , ]$ -brackets in M.

We quote from the 'Introduction and summary' of NEDERPELT [73]:

*"In this thesis we shall show that, if in a system all terms are normalizable into a unique normal form, then each term is strongly normalizable. This will be proved for a certain lambda-calculus called  $\lambda$ , the method can, however, be applied to more systems, and we suggest this as a field of further investigation."* In the present chapter we have endeavoured to follow this suggestion.

4.13. REMARK. There is an obvious resemblance between the method of proof in I.8 (where we prove SN for  $\lambda^{HW}$ ,  $\lambda^{L,P}$  and  $\lambda^T$  via an 'interpretation' in  $\lambda I_{[ , ]}$ -calculus) and Nederpelt's method which has led to Theorem 4.11 above. (Note the notational ambiguity:  $\lambda I_{[ , ]}$  in the sense of I.8 is not the same as  $\lambda I_{[ , ]}$  in the sense of Section 4 of the present Chapter.) This resemblance can be formulated abstractly as follows.

DEFINITION. Let  $A = \langle A, \xrightarrow{A} \rangle$  and  $B = \langle B, \xrightarrow{B} \rangle$  be ARS's. Let  $\iota: A \longrightarrow B$  and  $\kappa: B \longrightarrow A$  be maps such that

(i)  $\kappa \circ \iota = id_A$

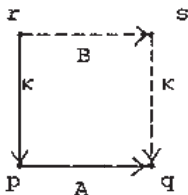

, i.e.  $\forall p, q \in A \forall r \in B \exists s \in B$

$$(r \xrightarrow{\kappa} p \xrightarrow{A} q \Rightarrow r \xrightarrow{B} s \xrightarrow{\kappa} q)$$

(Reductions in A can be 'lifted' to B.)

Then B is called an *associate* of A.

Now, both in I.8 in Theorem 4.11, the idea is to prove  $A \models SN$  by finding an associate B of A for which SN is easier to prove; for, obviously:

PROPOSITION. *If A,B are ARS's and B is an associate of A, then*  
 $B \models SN \Rightarrow A \models SN. \square$

In I.8, A,B are  $\lambda^{HW}$  resp.  $\lambda I_{[,] }^{HW}$ ,  $\iota$  is as defined in Def.I.8.11 and  $\kappa$  as in Def.I.8.6; and  $M \xrightarrow[B]{\beta} N$  iff  $M \xrightarrow{\beta} L \rightsquigarrow N$  for some L such that N is the  $[,]$ -normal form of L. So we have a situation as in the diagram (where A,B are as in the definition above):

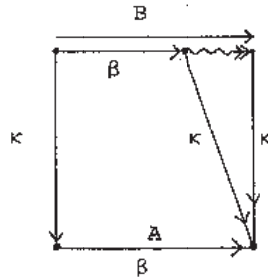

Furthermore, SN for the associate  $\lambda I_{[,] }^{HW}$  was easy to prove since  $\lambda I_{[,] }^{HW} \models NE$  (non-erasing; see Section I.7 and Section 5 below).

In Theorem 4.11, A and B are regular  $\Sigma$  resp.  $\Sigma_{[,] }$ ,  $\iota$  is the inclusion map,  $\kappa$  is as before and  $M \xrightarrow[B]{\beta} N$  iff  $M \xrightarrow{r_{[,] }} L \rightsquigarrow N$  for some  $r \in \text{Red}(\Sigma)$  and some L such that N is the  $[,]$ -normal form of L. So the situation is as in the diagram:

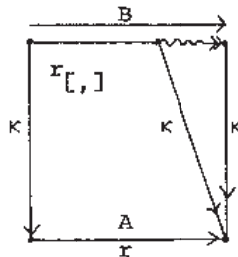

Here SN for the associate  $\Sigma_{[,] }$  was easy to prove since  $\Sigma_{[,] } \models \text{Inc}$ .

(In 1.8,  $\lambda I_{[.,.]}^{\text{HW}} \not\models \text{Inc}$ ; on the other hand  $\Sigma_{[.,.]} \models \text{NE}$ , as we will see below.)

4.14. REMARK. (i) Note that in 4.11 we also have proved.

$$\Sigma_{[.,.]} \models \text{WN} \Rightarrow \Sigma_{[.,.]} \models \text{SN},$$

hence for all  $\Sigma_{[.,.]}$  the equivalence  $\text{WN} \Leftrightarrow \text{SN}$  holds. Later on (in Section 5) we will generalize this equivalence to the class of all 'non-erasing' regular CRS's.

(ii) If  $\Sigma$  is a regular TRS, it is not hard to prove that

$$(*) \quad \Sigma \models \text{SN} \Rightarrow \Sigma_{[.,.]} \models \text{SN}.$$

(Proof sketch: consider an innermost  $\Sigma$ -reduction  $\mathcal{R}$  to the normal form. Let  $\mathcal{R}'$  be the corresponding  $\Sigma_{[.,.]}$ -reduction. Then the memory parts in  $\mathcal{R}'$  are in normal form, and hence  $\mathcal{R}'$  terminates, in just as many steps as  $\mathcal{R}$ , in a  $\Sigma_{[.,.]}$ -normal form. (So  $\Sigma_{[.,.]} \models \text{WN}$ . By (i), also  $\Sigma_{[.,.]} \models \text{SN}$ .)

Hence we have for regular TRS's  $\Sigma$ :

$$(**) \quad \Sigma \models \text{SN} \Leftrightarrow \Sigma_{[.,.]} \models \text{WN} \Leftrightarrow \Sigma_{[.,.]} \models \text{SN}.$$

For regular CRS's  $\Sigma$  in general, (\*) and (\*\*) require more effort; we will return to this matter in Remark 6.2.5.(ii).

(iii) Note that  $\Sigma \models \text{WN} \not\Rightarrow \Sigma_{[.,.]} \models \text{WN}$ ; for otherwise by Theorem 4.11, we would have  $\Sigma \models \text{WN} \Rightarrow \Sigma \models \text{SN}$  for all regular CRS's, an obvious contradiction.

The simplest example of a  $\Sigma$  such that  $\Sigma \models \text{WN}$  but  $\Sigma_{[.,.]} \not\models \text{WN}$  is the TRS with  $\text{Red}(\Sigma) = \{AZ \rightarrow B, C \rightarrow AC\}$ . Obviously every  $\Sigma$ -term has a normal form. However, in  $\Sigma_{[.,.]}$  where

$$\text{Red } \Sigma_{[.,.]} = \{AZ \rightarrow [B, A^*z], C \rightarrow [AC, C^*]\}$$

the term  $C$  has no normal form; for, the  $\Sigma_{[.,.]}$ -reduction  $\mathcal{R}$  (written in the subscript notation of 4.2(iii).):

$$\begin{array}{c}
 C \longrightarrow (AC)_{C^*} \longrightarrow B_{A^*}C, C^* \longrightarrow B_{A^*}(AC)_{C^*, C^*} \longrightarrow \dots \\
 \dots \longrightarrow \dots \longrightarrow \dots \\
 B_{A^*}B_{A^*}B_{A^*}B_{A^*}B_{A^*}B_{A^*}C, C^*, C^*, C^*, C^*, C^*
 \end{array}$$

is 'cofinal' in  $\mathcal{G}_{\Sigma[\cdot, \cdot]}(C)$ , the set of  $\Sigma[\cdot, \cdot]$ -reducts of  $C$  as in the figure below; hence every  $\Sigma[\cdot, \cdot]$ -reduct of  $C$  contains a redex  $C$ .

In the next two figures the reduction graphs  $\mathcal{G}_{\Sigma}(C)$  and  $\mathcal{G}_{\Sigma[\cdot, \cdot]}(C)$  are depicted. In the last reduction graph the abbreviations

$$\begin{aligned}
 c_1[\ ] &\equiv [A\Box, C^*] \\
 c_2[\ ] &\equiv [[B, A^*\Box], C^*]
 \end{aligned}$$

are used; moreover, 1210 denotes  $c_1[c_2[c_1[C]]]$ , etc. The bold line corresponds to the cofinal reduction  $\mathcal{R}$ .

$\mathcal{G}_{\Sigma}(C)$ :

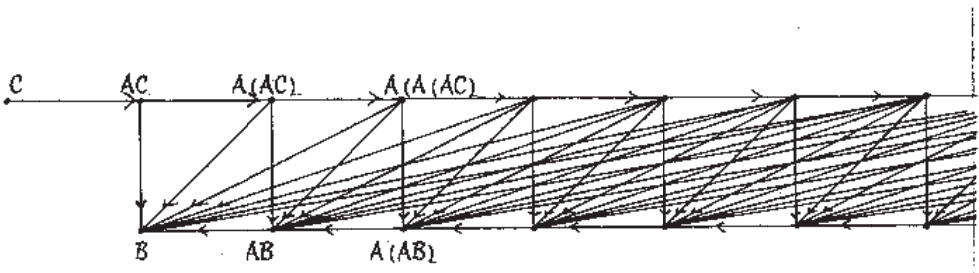

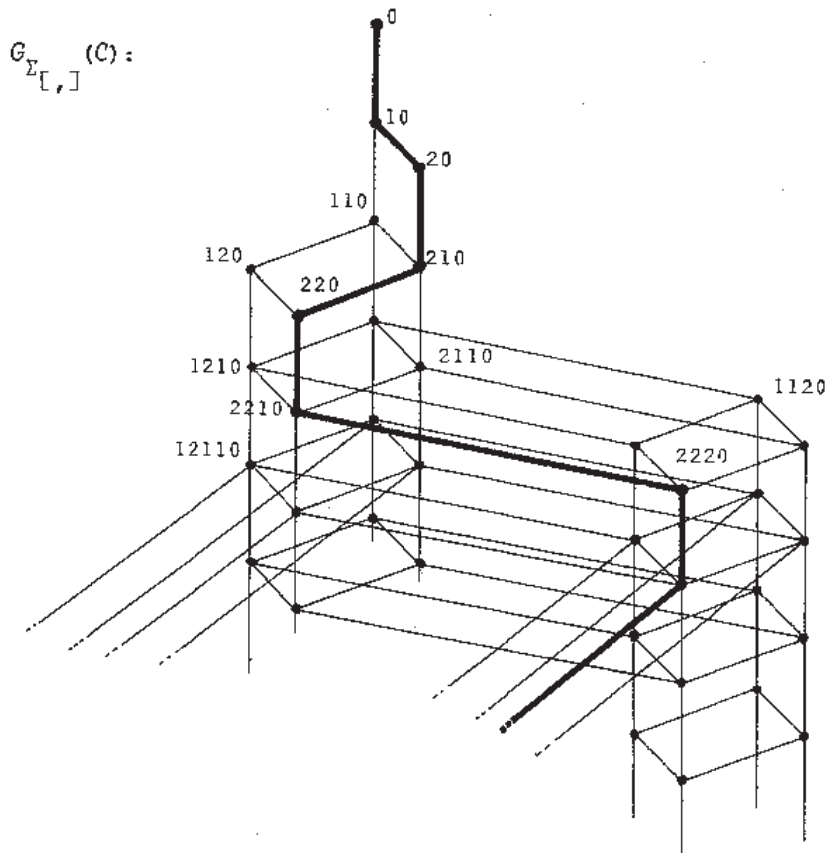

We will now state the corollaries of Theorem 4.11.

4.15 THEOREM (*Finite Developments*).

For all regular CRS's  $\Sigma: \underline{\Sigma} \models \text{SN}$ .

In other words:  $\Sigma \models \text{FD}$ .

PROOF.  $\forall \Sigma: \underline{\Sigma} \models \text{WN}$  (Corollary 3.9)

Hence  $\forall \Sigma: \underline{\Sigma}_{[\cdot, \cdot]} \models \text{WN}$ .

$\forall \Sigma: \underline{\Sigma}_{[\cdot, \cdot]} = \underline{\Sigma}_{[\cdot, \cdot]}$  (Proposition 4.8).

Hence  $\forall \Sigma: \underline{\Sigma}_{[\cdot, \cdot]} \models \text{WN}$

Therefore

$\forall \Sigma: \underline{\Sigma} \models \text{SN}$  (Theorem 4.11).  $\square$

4.16. COROLLARY (*Church-Rosser Theorem; Lemma of Parallel Moves*).

For all regular CRS's  $\Sigma$ :

(i)  $\Sigma \models \text{CR}^+$ , i.e. every construction of a  $\Sigma$ -reduction diagram, by

successive addition of elementary diagrams (as in Def.3.5) terminates in the same 'closed' diagram.

(ii)  $\Sigma \models \text{PM}$ , as in I.6.12.

PROOF. Entirely analogous to the proofs in I.6.9 and I.6.12.  $\square$

4.17. NOTATION. As in I.6,  $\mathcal{D}(\mathcal{R}_1, \mathcal{R}_2)$  denotes the reduction diagram determined by two cointial, finite reductions  $\mathcal{R}_1, \mathcal{R}_2$ . Likewise we employ the notation  $\mathcal{R}_1/\mathcal{R}_2$ , analogous to I.6.10.

## 5. NON-ERASING REDUCTIONS

The main properties of CRS's with memory  $\Sigma_{[ \ ]}$  are: non-erasure and Inc. We will now focus attention on these properties, especially the first one.

5.1. DEFINITION.  $\Sigma \models \text{NE}$  (' $\Sigma$  is non-erasing') iff for all  $M, N \in \text{Ter}(\Sigma)$ :

$$M \longrightarrow N \Rightarrow \underline{\text{FV}}(M) = \underline{\text{FV}}(N)$$

where  $\underline{\text{FV}}(M)$  is the set of free variables occurring in  $M$ .

5.2. PROPOSITION. The following are equivalent:

- (i)  $\Sigma \not\models \text{NE}$   
 (ii) there is a non-trivial context  $\mathbb{C}[ \ ]$  erasing a free variable  $x$ :

$$\mathbb{C}[x] \longrightarrow M \quad (x \notin \underline{\text{FV}}(M))$$

- (iii)  $\exists \mathbb{C}[ \ ] \exists M \forall N \mathbb{C}[N] \longrightarrow M$   
 (iv) there is an elementary diagram of the form  
 (Otherwise said: there is a non-trivial elementary diagram containing an empty step.)

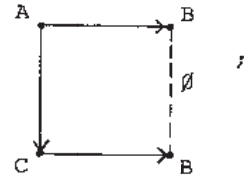

5.3. PROPOSITION. The following are equivalent:

- (i)  $\Sigma \models \text{NE}$   
 (ii) for all  $\Sigma$ -terms  $M$  and all pairs of distinct redexes  $\mathcal{R}_1, \mathcal{R}_2 \subseteq M$ , contraction of one leaves at least one residual of the other.  
 (iii) Let  $H \rightarrow H' \in \text{Red}(\Sigma)$  and let  $\rho H \rightarrow \rho H'$  be some instance of this rule.

Let  $H$  contain the meta-variable  $Z$ ; then  $\rho Z(\subseteq \rho H)$  has at least one descendant in  $\rho H'$  (except possibly when  $\rho Z \in \text{Var}$ ).

The routine proofs of these two propositions will be left to the reader.

5.4. EXAMPLES. (i)  $CL_{S,K,I}$  (Combinatory Logic based on the combinators  $S, K, I$ , Ch.I.2) is erasing and so is  $\lambda\beta$ -calculus.

(ii)  $CL_{I,J}$ , the  $\lambda I$ -version of CL with basic combinators  $I, J$  and rules  $Iz \rightarrow z, Jz_1z_2z_3z_4 \rightarrow z_1z_2(z_1z_4z_3)$  is NE; so is  $\lambda I$ -calculus.

(iii) Further,  $\forall \Sigma: \Sigma[\_, \_] \vdash \text{NE}$ .

(iv)  $\Sigma$  is a non-erasing TRS iff in each rule  $H \rightarrow H'$  the same meta-variables occur in  $H$  and  $H'$ .

5.5. PROPOSITION. (i)  $\text{WF} \Rightarrow \text{NE}$  (def. WF: I.5.16.(3))

(ii)  $\text{FB}^{-1} \Rightarrow \text{NE}$  (def.  $\text{FB}^{-1}$ : I.5.16.(4)).

PROOF. (i) We will prove the contraposition  $\neg \text{NE} \Rightarrow \neg \text{WF}$ . So assume that  $\Sigma \vdash \neg \text{NE}$ . Then by Prop.5.2 for some non-trivial context  $C[\_]$  and term  $M$  we have for all  $N$ :  $C[N] \rightarrow M$ . In particular:

$$\dots \rightarrow C[C[C[M]]] \rightarrow C[C[M]] \rightarrow C[M] \rightarrow M,$$

i.e.  $\Sigma \vdash \neg \text{WF}$ .

(ii) To prove  $\neg \text{NE} \Rightarrow \neg \text{FB}^{-1}$ . Let  $\Sigma \vdash \neg \text{NE}$ , then again by Prop.5.2.(iii):

$$\begin{array}{ccccccc} C[N_0] & C[N_1] & C[N_2] & \dots & & & \\ \downarrow & \swarrow & \swarrow & & & & \\ & M & & & & & \end{array}$$

Hence  $\neg \text{FB}^{-1}$ .  $\square$

5.6. DEFINITION. A CRS  $\Sigma$  is *finitely presented* iff  $\Sigma$  has a finite set  $Q$  of constants and a finite set of reduction rules  $\text{Red}(\Sigma)$ .

5.7. REMARK. Almost all well-known CRS's are finitely presented:  $\lambda\beta$ , CL, TRS's as defined in e.g. HUET [78], RPS's as in I.1.13. A notable exception is  $\lambda\beta \oplus$  Church's  $\delta$ -rules, see 1.15.(4) and 1.17.



5.8. THEOREM. For finitely presented regular CRS's  $\Sigma$  the following equivalences hold:

- (i)  $NE \iff FB^{-1}$   
(ii)  $WF \iff Inc.$

PROOF. (i)  $\iff$  is Proposition 5.5.(ii).

$\Rightarrow$ : Let the set of constants of  $\Sigma$  and  $Red(\Sigma)$  be finite. Suppose  $\Sigma \models NE$ . Let  $M \in Ter(\Sigma)$  and consider  $H = \{N \mid N \longrightarrow M\}$ . We have to prove that  $H$  is finite; i.e.  $\Sigma \models FB^{-1}$ .

Suppose  $H$  is infinite. Then, we claim, there must be arbitrarily long  $N \in H$ . The claim follows at once from the fact that the  $N \in H$  are built up from only finitely many different symbols, namely the  $\Sigma$ -constants and the free variables in  $FV(N) = FV(M)$  (the last equality by  $\Sigma \models NE$ ).

Now consider a "very long"  $N \in H$ , relative to  $|M|$ , the length of  $M$ , and to the LHS's of all the closed rules  $\epsilon \in Red(\Sigma)$ . Here a reduction rule is called 'closed' if its LHS contains no meta-variables (e.g. Church's  $\delta$ -rules). If the redex  $\rho H$  contracted in the step

$$N \equiv \mathcal{C}[\rho H] \xrightarrow{r} \mathcal{C}[\rho H'] \equiv M$$

is "small", then  $M$  would have the same order of length as  $N$ , contradiction. So our very large  $N$  contains a very large  $r$ -redex  $\rho H$ , where  $r = H \rightarrow H'$  cannot be a closed rule since  $\rho H$  is very large relative to the LHS's of the closed rules. Hence  $H$  contains meta-variables. Now for at least one of the meta-variables  $Z$  in  $H$ ,  $\rho Z$  must be very large. (Here we use that  $Red(\Sigma)$  is finite; hence the number of meta-variables  $Z$  in  $H$  is bounded.) By Proposition 5.3.(iii),  $\rho Z$  has a descendant in  $\rho H'$ , call it  $(\rho Z)'$ . It is evident that  $|\rho Z| \leq |(\rho Z)'|$ , since the only thing that can happen to  $\rho Z$  in the  $r$ -reduction step is that some variables in  $\rho Z$  are replaced by some terms. But then  $M$ , containing  $(\rho Z)'$ , is very large—contrary to the assumption.

(To make the above estimations numerical, put  $s =$  the total number of symbols in  $Red(\Sigma)$ . Then choose  $N$  such that  $|N| > 2(s+1)|M|$ ; now we have  $|\rho H| \geq \frac{1}{2}|N|$ , because  $|N| = |\mathcal{C}[ ]| + |\rho H|$  and  $|M| = |\mathcal{C}[ ]| + |\rho H'|$ ; and moreover we have  $|\rho H| \leq s|\rho Z| + s$  for some  $Z$  in  $H$ , since there are  $\leq s$  meta-variables  $Z$  in  $H$  and there are  $\leq s$  remaining symbols in  $H$ .

Therefore

$$|(\rho Z)'| \geq |\rho Z| \geq |\rho H| / (s+1) \geq |N| / 2(s+1) > |M|,$$

contradicting  $(\rho Z)' \subseteq M$ .)

(ii)  $\Leftarrow$  is trivial.

$\Rightarrow$ : by Proposition 5.5.(i),  $WF \Rightarrow NE$ , so by (i) of this theorem,  $WF \Rightarrow FB^{-1}$ . By Lemma I.6.10.(4),  $WF \& FB^{-1} \Rightarrow Inc$  for all Abstract Reduction Systems, in particular for all CRS's  $\Sigma$ .  $\square$

5.8.1. REMARK. (i) By Lemma I.5.19.(i):

$$WCR \& WN \& Inc \Rightarrow SN \text{ for ARS's.}$$

Hence, by Theorem 5.8.(ii) and the fact that for all regular CRS's the property WCR holds, we have for regular finitely presented CRS's:

$$(*) \quad WF \& WN \Rightarrow SN.$$

(ii) Below (in Corollary 5.9.4) we will strengthen (\*) to:

$$NE \& WN \Rightarrow SN, \text{ for all regular CRS's.}$$

That this is really a strenghtening of (\*) (apart from the fact that it holds for all regular CRS's), follows from the fact that  $WF \Rightarrow NE$  (Proposition 5.5), but not conversely (consider  $Red(\Sigma) = \{IZ \rightarrow Z\}$ ).

(iii) In advance, let us note the following curious consequence of the proposition in (ii):

PROPOSITION. Let  $\Sigma$  be a regular CRS and let  $N$  be a normal form in  $\Sigma$ . Suppose there is an  $M$  such that  $M \twoheadrightarrow N$  and  $M$  has an infinite reduction  $M \rightarrow M' \rightarrow M'' \rightarrow \dots$

Then there is an infinite 'inverse' reduction  $\dots \rightarrow N'' \rightarrow N' \twoheadrightarrow N$ , as in the figure:

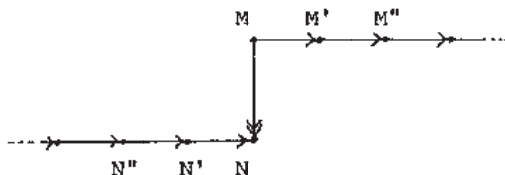

PROOF. Let  $[M] = \{M' \mid M' =_{\Sigma} M\}$  and consider the restriction of  $\Sigma$  to  $[M]$ ; call this  $\Sigma_M$ . Then  $\Sigma_M$  is a regular CRS (being a substructure of one); and since  $[M] (= \text{Ter}\Sigma_M)$  contains a normal form, by the CR theorem:  $\Sigma_M \models \text{WN}$ . By hypothesis  $\Sigma_M \not\models \text{SN}$ , so by the proposition in (ii),  $\neg \text{NE}$ . Hence  $\Sigma_M \models \neg \text{WF}$  (Proposition 5.5.(i)). So there is an infinite reduction in  $\Sigma_M$ , which by CR leads to the normal form N.  $\square$

(For  $\lambda, \text{CL}$  this proposition is trivial: consider the reduction  
 $\dots \rightarrow \text{IIIN} \rightarrow \text{IIN} \rightarrow \text{IN} \rightarrow \text{N}.$ )

5.9. The paradigm of a regular CRS which is non-erasing, is the  $\lambda\text{I}$ -calculus, which was considered in I.7. We have enough material now (namely  $\text{FD}, \text{CR}^+, \text{PM}$  in Theorems 4.15 and 4.16) to prove theorems for non-erasing CRS's in general, analogous to those in I.7. The proofs will be omitted as they are entirely analogous to those in I.7.

5.9.1. DEFINITION. We will say that 'the class of infinite  $\Sigma$ -reductions is closed under projections' (or 'infinite  $\Sigma$ -reductions are closed under projections') iff whenever  $\mathcal{R}$  is an infinite  $\Sigma$ -reduction and  $\mathcal{R}'$  a finite one, then  $\mathcal{R}/\mathcal{R}'$  is again infinite.

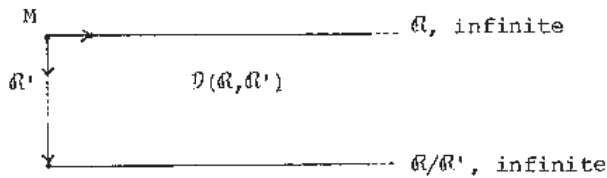

5.9.2. LEMMA. Let  $\Sigma$  be a regular CRS and suppose  $\Sigma \models \text{NE}$ . Then infinite  $\Sigma$ -reductions are closed under projections.  $\square$

5.9.3. CHURCH'S THEOREM for regular CRS's.

Let  $\Sigma$  be a non-erasing regular CRS. Then for all  $M \in \text{Ter}(\Sigma)$ , the following are equivalent:

- (i)  $M$  is weakly normalizing (has a normal form)
- (ii)  $M$  is strongly normalizing
- (iii) all subterms of  $M$  have a normal form.  $\square$

5.9.4. COROLLARY. For regular CRS's:  $\text{NE} \Rightarrow (\text{WN} \Leftrightarrow \text{SN}).$

PROOF. The assertion is short for:

$\forall$  regular CRS's  $\Sigma, \Sigma \models \text{NE} \Rightarrow (\Sigma \models \text{WN} \Leftrightarrow \Sigma \models \text{SN})$ .

This is merely the 'global' version of Church's Theorem, trivially implied by the 'local' version in 5.9.3.  $\square$

5.9.4.1. REMARK. Let  $A = \langle A, \rightarrow \rangle$  be an Abstract Reduction System as in I.5.1. Let  $\text{WCR}^1$  mean:

$\forall a, b, c \in A (b \neq c) \exists d \in A$

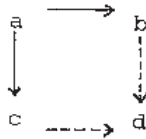

( $c \rightarrow d$  and  $b \rightarrow d$  exactly one step) and let  $\text{WCR}^{\geq 1}$  mean:

$\forall a, b, c \in A (b \neq c) \exists d \in A$

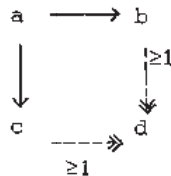

( $c \Rightarrow d$  and  $b \Rightarrow d$  consisting of at least one step).

Then, as NEWMAN [42] Thm.2 (essentially) remarks,  $\text{WCR}^1$  &  $\text{WN} \Rightarrow \text{SN}$ .

QUESTION: does also  $\text{WCR}^{\geq 1}$  &  $\text{WN} \Rightarrow \text{SN}$  hold for ARS's? A positive answer would result in an 'abstract' proof of  $\text{NE} \ \& \ \text{WN} \Rightarrow \text{SN}$  for regular CRS's, since  $\text{NE} \Leftrightarrow \text{WCR}^{\geq 1}$ .

However, the following ARS answers the question negatively:

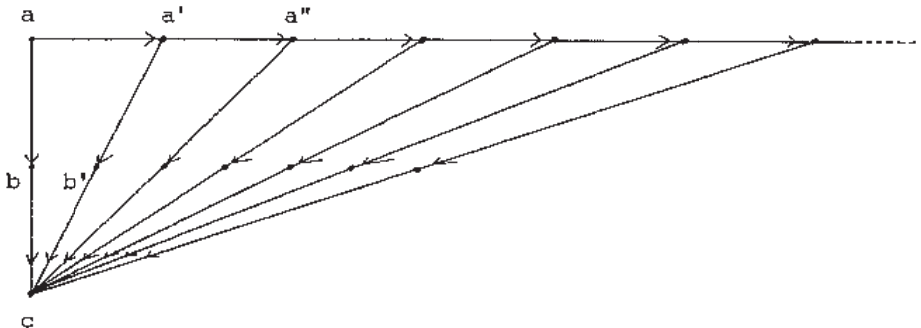

For regular TRS's we can strengthen Theorem 5.9.3 as follows.

5.9.5. DEFINITION. Let  $\Sigma$  be a regular TRS and  $r = H \rightarrow H'$  a rule in  $\text{Red}(\Sigma)$ . Then  $r$  is called *non-erasing* iff both sides  $H, H'$  contain the same meta-variables.

If  $r$  is a non-erasing rule, an  $r$ -redex is called a non-erasing redex. (E.g. in CL the  $\bar{I}$ - and  $\bar{S}$ -reduction rule are non-erasing.)

5.9.6. THEOREM. Let  $\Sigma$  be a regular TRS. Let  $\mathcal{R}: M \rightarrow M' \rightarrow \dots$  be an infinite  $\Sigma$ -reduction, and let  $R \subseteq M$  be a non-erasing redex. Then  $\mathcal{R}/\{R\}$  is again infinite.

("Infinite reductions are closed under non-erasing projections.")

PROOF.

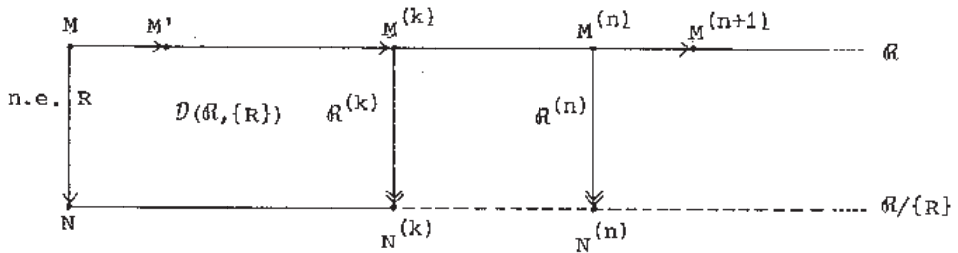

The proof is very similar to the one of Lemma I.7.2. Consider  $\mathcal{D}(R, \{R\})$  as in the figure. Suppose  $\mathcal{R}/\{R\}$  is finite; then after some  $N^{(k)}$ ,  $\mathcal{R}/\{R\}$  consists of empty steps. By the Parallel Moves Lemma (4.16) the reduction  $\mathcal{R}^{(k)}$  is a complete development of the set  $\mathcal{R}^{(k)}$  of residuals in  $M^{(k)}$  of the originally contracted redex  $R$ . Note that these residuals are again non-erasing.

Now let for some  $n \geq k$ ,  $M^{(n)} \rightarrow M^{(n+1)}$  be the first step in  $\mathcal{R}$  in which a redex is contracted that is not a residual of any member of  $\mathcal{R}^{(k)}$ . By Finite Developments (Thm.4.15) there must exist such an  $n$ .  $\mathcal{R}^{(n)}$  is a complete development of  $\mathcal{R}^{(n)}$ , the set of residuals of  $R$  in  $M^{(n)}$ . Obviously, every redex contracted in  $\mathcal{R}^{(n)}$ , is non-erasing, being of the same kind as  $R$  was.

We claim that the projection of this step, i.e.  $M^{(n)} \rightarrow M^{(n+1)}/\mathcal{R}^{(n)}$ , cannot be  $\emptyset$ , however. The proof of the claim is entirely similar to that in Lemma I.7.2.  $\square$

5.9.6.1. REMARK. For regular CRS's in general, Theorem 5.9.6 fails, as is suggested by the above proof and is shown by the following counterexample from BARENDREGT e.a. [76], Ch.II.5:

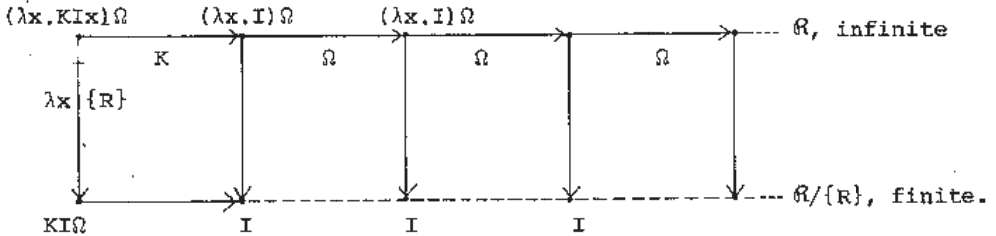

Analogous to the preceding theorem we have

5.9.7. THEOREM. Let  $\Sigma$  be a regular TRS,  $R: M \rightarrow M' \rightarrow \dots$  an infinite reduction, and  $R \subseteq M$  an innermost redex (i.e. not containing other redexes). Then  $R/\{R\}$  is again infinite.

("Infinite reductions are closed under innermost projections.")

PROOF. Analogous to the proof of 5.9.6, using the following proposition which is easily verified:

Let  $\Sigma$  be a regular TRS,  $M$  a  $\Sigma$ -term containing redexes  $R_1, R_2$  such that  $R_1 \neq R_2$  and  $R_2$  is an innermost redex. Then:

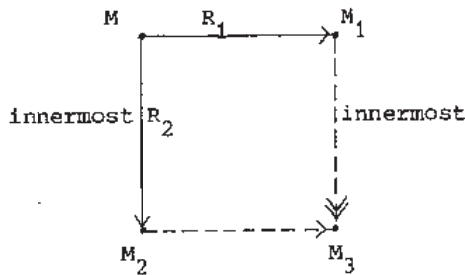

(Note that (i)  $M_2 \rightarrow M_3$  is one step and (ii)  $M_1 \rightarrow M_3$  is an innermost reduction.)  $\square$

5.9.8. COROLLARY (O'Donnell).

(i) Let  $\Sigma$  be a regular TRS and let there be an innermost reduction  $R: M \rightarrow \dots \rightarrow N$  to the normal form  $N$ .

Then  $M$  is strongly normalizing.

(ii) For all regular TRS's  $\Sigma$ :

$$\Sigma \models \text{WIN} \iff \text{SN},$$

where 'WIN' (Weak Innermost Normalization) is the property that every term has a normal form which can be reached by an innermost reduction.

PROOF. (ii) is merely the 'global' version of (i).

(i): Let  $\mathcal{R}' : M \rightarrow \dots$  be an infinite reduction and  $\mathcal{R} : M \rightarrow \dots \rightarrow N$  be an innermost reduction to the normal form  $N$ .

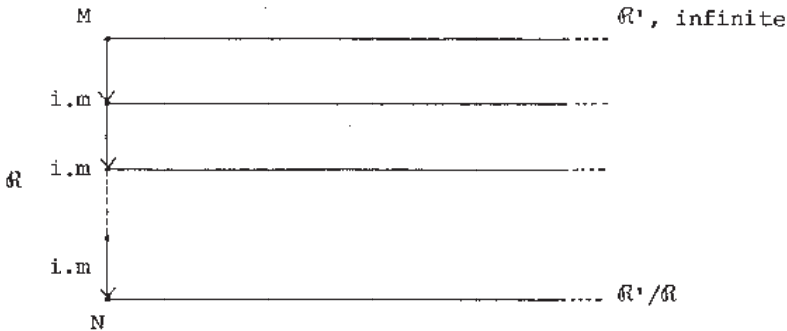

Then by Theorem 5.9.7,  $\mathcal{R}'/\mathcal{R}$  is infinite, contradicting the fact that  $N$  is a normal form. Hence  $M \in \text{SN}$ .  $\square$

5.9.8.1. REMARK. (i) Corollary 5.9.8 is a consequence of O'DONNELL [77] (Thm.11 p.53), as is seen by noting that for regular TRS's the residual concept satisfies the requirements stated there (Def.22), and by noting that regular TRS's fulfill the property "Innermost Preserving" (Def.35) defined there.

(ii) It is easy to give a counterexample to 5.9.7 and 5.9.8 for regular CRS's in general, analogous to the counterexample in 5.9.6.1, since e.g.  $\lambda$ -calculus is not "Innermost Preserving" due to substitution.

5.9.8.2. APPLICATION. (*Bar recursive terms*)

TAIT [71] considers the TRS  $\Sigma = \text{CL}^\top$  (typed Combinatory Logic)  $\oplus \{R, B, O, S\}$  where  $R$  is the Recursor having reduction rules as in Example 1.12.(ii),  $B$  is the Bar recursion operator with reduction rules

$$\mathbb{B}z_1 z_2 z_3 z_4^n \longrightarrow \dots$$

for each  $n$  (short for  $\delta^n 0$ ).

(The precise form of the RHS is not important for us)

In fact there are constants  $S, K, R, B$  for each appropriate type. It is easy to see that  $\Sigma$  is a regular TRS; also if the types are viewed as 'internal', i.e. as elements of  $\text{Ter}(\Sigma)$ .

An extension of  $\Sigma$  is  $\Sigma' = \Sigma \oplus$  constants  $\{f\}$  for all functions  $f: \mathbb{N} \rightarrow \mathbb{N}$  and rules

$$(f, \sigma) \longrightarrow t(f, n, \sigma)$$

where  $\sigma$  is a type and  $t(f, n, \sigma)$  is some term depending on  $f, n, \sigma$  of which the precise form is not important for us. To write these rules in our notation, we can adopt a constant  $C$  (for 'choice sequence') and write

$$C\sigma f \longrightarrow t(f, n, \sigma).$$

Note that moreover  $\Sigma'$  is a regular TRS.

Now TAIT [71] proves, in our terminology, that both  $\Sigma$  and  $\Sigma'$  satisfy WIN. Hence by Theorem 5.9.8, also  $\Sigma, \Sigma' \models \text{SN}$ .

5.10. In the following figure we summarize some facts treated in this section, which hold for regular CRS's. Here "f.p" is "finitely presented" (Def.5.6)

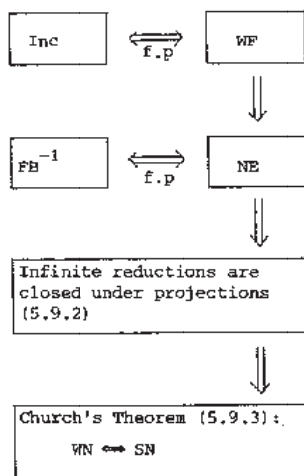



5.11. DISCUSSION. Before we proceed to prove some more theorems about Strong Normalization of regular CRS's in the next section, let us consider the possibility of generalizing some theorems proved in Chapter I for definable extensions of  $\lambda$ -calculus, namely those concerning:

- (1) Equivalence of reductions
- (2) Standardization
- (3) Normalization
- (4) Cofinality of Knuth-Gross reductions.

Ad(1). The definition of 'Lévy-equivalence' of reductions, and Lévy's results thereabout, generalize at once to the present case of regular CRS's.

Ad(2). Standardization, however, is much more complicated in the present case than for definable extensions of  $\lambda$ -calculus. This was pointed out by Hindley, for the case of  $\lambda$ -calculus  $\oplus$  recursor  $R$ ; see some examples in HINDLEY [78]. See also Remark 6.2.8.6.(ii).

For regular TRS's a Standardization theorem is proved by HUET-LÉVY [79]. It is remarked there that the theorem seems to extend to 'applicative rewriting systems with bound variables', i.e. to CRS's.

At the end of this Chapter (see 6.2.8) we will prove the Standardization theorem for 'left-normal' regular CRS's.

Ad(3). The Normalization Theorem (I.11.2), saying that repeated contraction of the leftmost redex must lead to the normal form if it exists, does not carry over, as observed in HUET-LÉVY [79], where the following example is given. If  $\text{Red}(\Sigma) = \{FzA \rightarrow B, C \rightarrow C, D \rightarrow A\}$  then the term  $FCD$  has a normal form:  $FCD \rightarrow FCA \rightarrow B$ , but the leftmost reduction is infinite:  $FCD \rightarrow FCD \rightarrow \dots$  (repeated contraction of the redex  $C$ ).

In 6.2.8 we will prove the Normalization Theorem for 'left-normal' regular CRS's, as a corollary of the Standardization Theorem which we just mentioned.

In HUET-LÉVY [79] the following interesting regular CRS is considered (the example is basically due to G. Berry):

$$\begin{aligned} \text{Red}(\Sigma) = \{ & FzAz \rightarrow C \\ & FBzA \rightarrow C \\ & FzAB \rightarrow C \} \end{aligned}$$

which leads to the question:

*does there exist a recursive one step normalizing strategy for every regular CRS? (or, for every regular TRS?)*

We conjecture that the answer is negative; see for a discussion of the problem HUET-LÉVY [79]. (For a precise definition of the concepts in the question, see BARENDREGT [80]. A likely candidate to establish the negative answer may be:  $CL \oplus$  the above mentioned  $\Sigma$ .)

Ad(4). The definition of Knuth-Gross (KG) reduction (see I.12.4) extends readily to the present case, and so does the theorem (I.12.5) stating that KG-reductions are cofinal. So KG-reductions are normalizing; and hence we have a recursive 'many step' normalizing reduction strategy for regular CRS's.

Also the refinement (I.12.3) stating that secured reductions are cofinal, generalizes without problems to the case of regular CRS's.

## 6. DECREASING LABELINGS AND STRONG NORMALIZATION

In this section we will prove some more theorems from which one can infer Strong Normalization for regular CRS's. We remark that the proof of SN, so obtained, does not require stronger means, metamathematically speaking, than the proof of WN (Weak Normalization) for the system under consideration. To be more specific: where a proof of WN uses transfinite induction to the ordinal  $\alpha$ , the proof of SN as obtained here requires transfinite induction to  $\omega^\alpha$ . (For 'Gödel's  $\bar{T}$ ', see 6.1.7 below, we have  $\alpha = \omega^\alpha = \epsilon_0$ .) So if a WN-proof can be formalized in Peano's Arithmetic (i.e. if  $\alpha < \epsilon_0$ ), then the SN-proof can also be formalized in P.A.

6.1. For convenience we will restrict ourselves in this subsection 6.1 to regular TRS's; but an extension to regular CRS's does not seem to be essentially problematic. First two preliminary definitions.

6.1.1. DEFINITION. Let  $\Sigma$  be a regular TRS. Then  $\Sigma'[\ ]$  is the regular TRS defined analogously to  $\Sigma[\ ]$  (Def.4.5), with the only change that in a reduction rule *only the erased metavariables* are repeated ('memorized').

6.1.1.1. EXAMPLE. Let  $\Sigma$  be  $CL \oplus \{J, \delta, \theta\}$ , where CL is Combinatory Logic based on  $I, K, S$ , and where the iterator  $J$  has reduction rules as in Example

1.15.(3).

Then

$$\begin{aligned} \text{Red}(\Sigma'_{[\cdot, \cdot]}) = \{ & [Z \longrightarrow [Z, I^*Z] \\ & KZ_1Z_2 \longrightarrow [Z_1, K^*Z_1Z_2] \\ & SZ_1Z_2Z_3 \longrightarrow [Z_1Z_3(Z_2Z_3), S^*Z_1Z_2Z_3] \\ & J0_{\vec{Z}}Z_1Z_2 \longrightarrow [Z_2, J^*0_{\vec{Z}}Z_1Z_2] \\ & J(\Delta Z')_{\vec{Z}}Z_1Z_2 \longrightarrow [Z_1(JZ'Z_1Z_2), J^*(\Delta Z')_{\vec{Z}}Z_1Z_2]\}. \end{aligned}$$

(Here  $\vec{Z} = Z_{01}, Z_{02}, \dots, Z_{0m}$  for some  $m \geq 0$ , so the last two rules are in fact schema's for rules; see Def.4.5.).

On the other hand,

$$\begin{aligned} \text{Red}(\Sigma'_{[\cdot, \cdot]}) = \{ & [Z \longrightarrow Z \\ & KZ_1Z_2 \longrightarrow [Z_1, Z_2] \\ & SZ_1Z_2Z_3 \longrightarrow Z_1Z_3(Z_2Z_3) \\ & J0_{\vec{Z}}Z_1Z_2 \longrightarrow [Z_2, Z_1, \vec{Z}] \\ & J(\Delta Z')_{\vec{Z}}Z_1Z_2 \longrightarrow [Z_1(JZ'Z_1Z_2), \vec{Z}]\}. \end{aligned}$$

6.1.2. PROPOSITION. Theorem 4.11 holds with  $\Sigma_{[\cdot, \cdot]}$  replaced by  $\Sigma'_{[\cdot, \cdot]}$ . I.e. for all regular CRS's  $\Sigma$ :  $\Sigma'_{[\cdot, \cdot]} \models \text{WN} \Rightarrow \Sigma \models \text{SN}$ .

PROOF.  $\Sigma'_{[\cdot, \cdot]} \models \text{NE}$ , hence:  $\Sigma'_{[\cdot, \cdot]} \models \text{WN} \Rightarrow \Sigma'_{[\cdot, \cdot]} \models \text{SN}$ , by Coroll.5.9.4. The proof of the implication  $\Sigma'_{[\cdot, \cdot]} \models \text{SN} \Rightarrow \Sigma \models \text{SN}$  is analogous to the one in Lemma 4.10.  $\square$

6.1.3. DEFINITION. Let  $\Sigma$  be a regular TRS and  $M \in \text{Ter}(\Sigma'_{[\cdot, \cdot]})$ . Then the set of occurrences of memorized subterms of  $M$ , notation  $\text{Sub}_{[\cdot, \cdot]}(M)$ , is defined inductively as follows:

- (i)  $\kappa(M) \in \text{Sub}_{[\cdot, \cdot]}(M)$ . Here  $\kappa(M)$  is the  $k$ -normal form of  $M$  ( $k$  is the 'forgetful' reduction rule defined in 4.4); so  $\kappa(M)$  is the result of erasing all memorized subterms in  $M$ .
- (ii)  $A_B \equiv [A, B] \subseteq M \Rightarrow \kappa(B) \in \text{Sub}_{[\cdot, \cdot]}(M)$ .

6.1.3.1. NOTATION. Instead of  $N \in \text{Sub}_{[\cdot, \cdot]}(M)$ , we will write also:  $N \subseteq_{[\cdot, \cdot]} M$ .

6.1.4. EXAMPLE and REMARK. (i) If  $T \equiv (A_{(DE)_{J,K,F,L}^B})_{GH_{MN,O}^I}^C$ , having the shift-n.f.

(See Def.4.4):

$$T' \equiv (ABC)_{(DE)_{J,K,F,L}^B}^I_{GH_{MN,O}^I}$$

then  $\text{Sub}_{[\cdot, \cdot]}(T) = \text{Sub}_{[\cdot, \cdot]}(T') = \{ABC, DE, F, GHI, J, K, L, MN, O\}$ .

(ii) It is easy to see that  $\text{Sub}_{[\cdot, \cdot]}(T)$  is invariant under 'shift'.

(iii) Note that  $\text{Sub}_{[\cdot, \cdot]}(T) \subseteq \text{Ter}(\Sigma)$  (more precisely, the terms having an occurrence in  $\text{Sub}_{[\cdot, \cdot]}(T)$  are  $\Sigma$ -terms).

(iv)  $S \subseteq_{[\cdot, \cdot]} T$  does not necessarily imply  $S \subseteq T$ ; unless  $S$  is "innermost w.r.t.  $\subseteq_{[\cdot, \cdot]}$ ". E.g.  $ABC, GHI \not\subseteq T$ , but  $MN \subseteq T$  in (i).

6.1.5. DEFINITION. Let  $\Sigma$  be a regular TRS.

(i) Let  $|\cdot|: \text{Ter}(\Sigma) \rightarrow \text{ORD}$  be an ordinal assignment (or ordinal labeling). Here ORD is the class of ordinals.

Then  $\Sigma \models \text{WN}_{|\cdot|}$  (" $\Sigma$  is weakly normalizing w.r.t.  $|\cdot|$ ") iff for all  $M \in \text{Ter}(\Sigma)$  not in normal form, there is a reduction step  $M \rightarrow M'$  such that  $|M| > |M'|$ .

(ii)  $\Sigma \models \text{DL}$  (" $\Sigma$  has a decreasing labeling") iff there is a labeling  $|\cdot|: \text{Ter}(\Sigma) \rightarrow \text{ORD}$  satisfying:

- (1)  $\Sigma \models \text{WN}_{|\cdot|}$
- (2)  $M \not\subseteq N \Rightarrow |M| < |N|$ .

(iii)  $\Sigma \models \text{DL}'$  iff there is a labeling  $|\cdot|: \text{Ter}(\Sigma) \rightarrow \text{ORD}$  satisfying:

- (1)  $\Sigma \models \text{WN}_{|\cdot|}$
- (2)  $M \subseteq N \Rightarrow |M| \leq |N|$
- (3) if  $R \equiv \mathcal{Q}A_1 \dots A_n$  ( $n \geq 0$ ) is a redex, then  $|R| > |A_i|$  ( $i = 1, \dots, n$ ) (I.e. a redex is 'heavier' than any of its arguments.)

(iv)  $\Sigma \models \text{DL}''$  iff there is a labeling  $|\cdot|$  satisfying:

- (1)  $\Sigma \models \text{WN}_{|\cdot|}$
- (2)  $M \subseteq N \Rightarrow |M| \leq |N|$

(3) A redex is heavier than any of its erasable subterms. I.e.: let

$r = H \rightarrow H'$  be a rule in  $\text{Red}(\Sigma)$ , and let  $Z$  be a metavariable occurring in  $H$ , but not in  $H'$ . Let  $\rho$  be a valuation; so  $\rho H$  is a redex containing the 'erasable' subterm  $\rho Z$ . Then  $|\rho H| > |\rho Z|$ .

6.1.6. THEOREM. Let  $\Sigma$  be a regular TRS. Then the following equivalences hold for  $\Sigma$ :

$$DL \iff DL' \iff DL'' \iff SN.$$

PROOF.  $DL \Rightarrow DL' \Rightarrow DL''$  follows at once from Def.6.1.5. The proof of  $SN \Rightarrow DL$  is easy: suppose  $\Sigma \models SN$  and  $M \in \text{Ter}(\Sigma)$ . Consider the reduction graph  $G(M) = \{N \in \text{Ter}(\Sigma) \mid M \rightarrow N\}$ . Now define  $|\cdot| : \text{Ter}(\Sigma) \rightarrow \mathbb{N}$  by  $|M| = \text{total number of symbols in } G(M)$ , i.e.  $\sum_{N \in G(M)} \ell(N)$  where  $\ell(N)$  is the length of  $N$ .

(By  $SN$ ,  $|M|$  is indeed defined.) Then it is not hard to verify that  $\Sigma \models DL$ .

It remains to prove  $DL'' \Rightarrow SN$ . Suppose  $\Sigma \models DL''$ ; let  $|\cdot|$  be an ordinal labeling such that the property  $DL''$  holds. Now assign to  $M \in \text{Ter}(\Sigma'_{[\cdot, \cdot]})$  a multi-set  $\|M\|$  (see Def.I.6.4.1 and Prop.I.6.4.2) as follows:

$$(*) \quad \|M\| = \langle |N| \mid N \sqsubseteq_{[\cdot, \cdot]}(M) \ \& \ N \text{ is not a normal form} \rangle.$$

CLAIM: there is a  $\Sigma'_{[\cdot, \cdot]}$ -reduction step  $M \rightarrow M'$  such that  $\|M\| \succ \|M'\|$  (in the sense of Proposition I.6.4.2.), unless  $M$  is already in  $\Sigma'_{[\cdot, \cdot]}$ -normal form (equivalently: unless all  $N \sqsubseteq_{[\cdot, \cdot]} M$  are in  $\Sigma$ -normal form).

If the claim is proved, we are through. For then  $\Sigma'_{[\cdot, \cdot]} \models WN$ , since  $\succ$  is a well-ordering by Proposition I.6.4.2; hence  $\Sigma \models SN$  by Proposition 6.1.2.

PROOF OF THE CLAIM. Select  $N \sqsubseteq_{[\cdot, \cdot]} M$  satisfying

(a)  $N$  is not a  $\Sigma$ -n.f. and

(b)  $N$  is innermost w.r.t.  $\sqsubseteq_{[\cdot, \cdot]}$  (see Remark 6.1.4.(iv)) such that (a) holds.

By  $\Sigma \models DL''$ , there is a  $\Sigma$ -reduction step  $N \xrightarrow{R} N'$  such that  $|N| > |N'|$ .

Now we copy in  $\Sigma'_{[\cdot, \cdot]}$  that reduction step:

$$M \equiv C[N^*] \longrightarrow C[N'^*] \equiv M',$$

where  $N^*, N'^*$  are such that  $\kappa(N^*) \equiv N$  and  $\kappa(N'^*) \equiv N'$ . So if  $\|M\| = \langle |N|, |P|, \dots \rangle$ , then either

$\|M'\| = \langle |N'|, |Q_1|, \dots, |Q_m|, |P|, \dots \rangle$  if  $N'$  is not yet in  $\Sigma$ -n.f. and for some  $m \geq 0$ , subterms  $Q_1, \dots, Q_m$  not in n.f. were erased; or

$\|M'\| = \langle |Q_1|, \dots, |Q_m|, |P|, \dots \rangle$  if  $N'$  is in  $\Sigma$ -n.f. and the  $Q_i$  are as above. In both cases the ordinal  $|N|$  in the multiset  $\|M\|$  is replaced by some lesser ordinals in  $\|M'\|$ , since  $|N| > |N'|$  by DL" (1) as noted above, and since  $|Q_i| < |R| \leq |N|$  by DL" (3) resp. DL" (2).

(That the multiset  $\|M\|$  is otherwise not affected, i.e. that none of the  $|P|, \dots$  is multiplied, follows because in the step  $N \xrightarrow{R} N'$  subterms which are multiplied, must be in normal form by (b) and hence do not count in  $\|M'\|$ , by the restriction in (\*).)

So by Prop. I.6.4.2 we have indeed  $\|M\| \succ \|M'\|$ .  $\square$

6.1.7. APPLICATION. Consider the CRS  $T = CL^T$  (typed Combinatory Logic) plus Iterator  $J$  and constants  $n$  for  $n \in \mathbb{N}$ . For this regular TRS ("Gödel's  $T$ ") SCHÜTTE [77] (§16) proves  $WN$  via an argument due to W. Howard. This proof shows that

$$(1) \quad M \xrightarrow{\text{leftmost}} M' \Rightarrow [M]_0 \succ [M']_0$$

where  $[ ]_0: \text{Ter}(T) \rightarrow \epsilon_0$  is an ordinal assignment. Furthermore, an inspection of the definition of  $[ ]_0$  and a short calculation show that

$$(2) \quad N \subseteq M \Rightarrow [N]_0 \leq [M]_0$$

$$(3) \quad [KAB]_0 \succ [B]_0 \quad \text{and} \quad [J0AB]_0 \succ [A]_0.$$

Hence (see Def. 6.15(iv)) we have  $T \models DL^n$ . Hence by the preceding theorem,  $T \models SN$ .

6.2. In this subsection we consider again all regular CRS's. We will prove another theorem (6.2.4) inferring  $SN$  from a 'decreasing labeling'; however, now the labels will not be assigned to all subterms of the terms  $M$  in question as in 6.1, but only to the redexes of  $M$ . Cf. the 'degrees' of redexes in  $\lambda^{HW}$  and  $\lambda^{L,P}$  in I.3.7.1 and I.3.9. In fact, Theorem 6.2.4 will generalize Theorem I.8.14 to all regular CRS's  $\Sigma$  having a certain assignment of degrees. Analogously to  $\lambda^{L,P}$  and  $\lambda^{HW}$  we will define  $\Sigma^{L,P}$  and  $\Sigma^{HW}$ , and prove  $SN$  for those CRS's; an application is the Standardization and Normalization Theorem for a subclass of regular CRS's.

6.2.1. DEFINITION. Let  $\Sigma$  be a regular CRS.

(i)  $\mathcal{R}(\Sigma) \subseteq \text{Ter}(\Sigma)$  is the set of redexes of  $\Sigma$ . If  $M \in \text{Ter}(\Sigma)$ , then  $\mathcal{R}(M)$

is the set of *redex occurrences* in  $M$ .

- (ii) Let  $M_1, M_2 \in \text{Ter}(\Sigma)$ . Then  $M_1 \xrightarrow{\text{redex}} M_2$  iff there is a  $\Sigma$ -reduction step  $\mathcal{C}[M_1] \longrightarrow \mathcal{C}'[M_2]$  in which  $M_2$  is a descendant of  $M_1$ .
- (iii) Let  $R_1, R_2 \in \mathcal{R}(\Sigma)$ . Then  $R_1 \xrightarrow{\text{redex}} R_2$  iff there is a  $\Sigma$ -reduction step  $\mathcal{C}[R_1] \longrightarrow \mathcal{C}'[R_2]$  in which the redex  $R_1$  is contracted and  $R_2$  has no ancestor in  $\mathcal{C}[R_1]$ . (" $R_1$  creates  $R_2$ ")

6.2.2. DEFINITION. Let  $\Sigma$  be a regular CRS. Then  $\Sigma \models \text{DR}$  (' $\Sigma$  has a decreasing redex labeling') iff there is a map  $\# : \mathcal{R}(\Sigma) \longrightarrow \text{ORD}$  satisfying for all  $R_1, R_2 \in \mathcal{R}(\Sigma)$ :

- (i)  $R_1 \xrightarrow{\text{redex}} R_2 \Rightarrow \#(R_1) \geq \#(R_2)$   
 (ii)  $R_1 \xrightarrow{\text{redex}} R_2 \Rightarrow \#(R_1) > \#(R_2)$ .

( $\#(R)$  will be called the *degree* of  $R$ .)

6.2.3. PROPOSITION. For all regular CRS's:  $\text{DR} \Rightarrow \text{WN}$ .

PROOF. Let  $\Sigma$  be a regular CRS such that  $\Sigma \models \text{DR}$  and let  $M \in \text{Ter}(\Sigma)$ . Define  $\|M\| =$  the multiset  $\langle \#(R) \mid R \in \mathcal{R}(M) \rangle$ . Now in an innermost reduction step  $M \xrightarrow{\text{i.m.}} N$  we have  $\|M\| \succ \|N\|$ , since  $R$  does not multiply already existing redexes and the possibly in  $N$  created redexes have degree  $< \#(R)$ . Therefore by Proposition I.6.4.2 every innermost reduction must terminate. Hence  $\Sigma \models \text{WN}$ .  $\square$

6.2.4. THEOREM. For regular CRS's:  $\text{DR} \Rightarrow \text{SN}$ .

PROOF. We claim that  $\Sigma \models \text{DR} \Rightarrow \Sigma_{[\cdot, \cdot]} \models \text{DR}$ , for regular  $\Sigma$ . For, suppose  $\Sigma \models \text{DR}$  and let  $\# : \mathcal{R}(\Sigma) \longrightarrow \text{ORD}$  be the given degree assignment of  $\Sigma$ ; we want to extend  $\#$  to a degree assignment  $\#_{[\cdot, \cdot]} : \mathcal{R}(\Sigma_{[\cdot, \cdot]}) \longrightarrow \text{ORD}$  with the required properties as in Definition 6.2.2. To this end, define  $\#_{[\cdot, \cdot]}(R) = \# \kappa(R)$  where  $\kappa$  is the memory-parts erasing function from Definition 4.4.(i).

NOTATION: If  $R$  is a redex and  $d$  its degree, we write  $R^d$ .

Now the claim follows, because if in  $\Sigma_{[\cdot, \cdot]}$ :

$$\begin{array}{ccc}
 M \longrightarrow M' & \text{resp.} & M \xrightarrow{R} M' \\
 \cup \mid & & \cup \mid \cup \mid \\
 R^d \xrightarrow{\text{redex}} R'^d & & R^d \xrightarrow{\text{redex}} R'^d,
 \end{array}$$

then it is routine to check that  $\kappa(R) \dashv\dashv \rightarrow \kappa(R')$  resp.  $\kappa(R) \rightsquigarrow \kappa(R')$ . So we have  $d \geq d'$  resp.  $d > d'$ , which proves the claim.

Hence  $\Sigma \models DR \Rightarrow \Sigma_{[ , ]} \models DR \Rightarrow \Sigma_{[ , ]} \models WN \Rightarrow \Sigma \models SN$ , where the middle implication is justified by Proposition 6.2.3 and the last by Theorem 4.11.  $\square$

6.2.5. REMARK. (i) The converse of this theorem does not hold, as the following simple counterexample shows: consider the fragment  $\Sigma$  of CL consisting of those terms which contain only  $K$ 's and the usual rule for  $K$ . Then obviously  $\Sigma \models SN$  since every  $\Sigma$ -term (e.g.  $K(KKK)KK$ ) will be shortened in a reduction. But  $\Sigma \not\models DR$ , since  $R_1 \equiv KKK \rightsquigarrow KKK \equiv R_2$ , i.e. the redex  $KKK$  can create itself, as in the step  $R_1 KK \equiv KKKKK \rightarrow KKK \equiv R_2$ .

(ii) However, it is possible to define a refined version  $DR'$  of the property  $DR$ , by specification of the context in which we have  $R_1 \dashv\dashv \rightarrow R_2$  resp.  $R_1 \rightsquigarrow R_2$  as in Def.6.2.2. The degree assignment is then to pairs  $(M, R)$  where  $R \in \mathcal{IR}(M)$ . Then one can prove:  $DR' \Leftrightarrow SN$ . As in the proof of Theorem 6.2.4 we have  $\Sigma \models DR' \Rightarrow \Sigma_{[ , ]} \models DR'$ . So  $\Sigma \models SN \Rightarrow \Sigma \models DR' \Rightarrow \Sigma_{[ , ]} \models DR' \Rightarrow \Sigma_{[ , ]} \models SN$ , which yields a strengthening of Theorem 4.11 to:

For all regular CRS's,  $\Sigma \models SN \Leftrightarrow \Sigma_{[ , ]} \models WN \Leftrightarrow \Sigma_{[ , ]} \models SN$ . (See also Remark 4.14.(ii).)

6.2.6. REMARK. Note that Theorem I.8.14, stating that  $\lambda^{HW}, \lambda^T, \lambda^{L,P}$  (for bounded  $P$ )  $\models SN$ , is a corollary of Theorem 6.2.4, since as remarked in I.3.7 and I.3.9, these CRS's have the property  $DR$ .

### 6.2.7. Application of Theorem 6.2.4: SN for Lévy-labeled regular CRS's

In I.10 we gave a (second) proof of the Standardization Theorem for  $\lambda\beta$ -calculus in which essential use was made of the fact that  $\lambda^{L,P} \models SN$  (Theorem I.8.14) or equivalently  $\lambda^{HW} \models SN$ . Now we would like to have analogous  $L$ -labelings or  $HW$ -labelings for CL and prove  $CL^{HW}, CL^{L,P} \models SN$ , in order to let this proof of the Standardization Theorem carry over to CL. One method to obtain such a labeling and labeled reduction, is via  $\lambda$ -calculus, since CL can be defined in  $\lambda$ -calculus. The result is however a bit cumbersome (our procedure in the sequel will yield a simpler labeled reduction) and moreover, we would like to have a more systematic way of adding Lévy-labels to not only CL, but every regular CRS. We will now describe how Lévy's labeling (or that of Hyland-Wadsworth) and the



corresponding SN theorem can be generalized to regular CRS's  $\Sigma$ : to each  $\Sigma$  we will associate a  $\Sigma^L$  (or  $\Sigma^{HW}$ ) and prove as a corollary of Theorem 6.2.4 that  $\Sigma^{L,P} \models \text{SN}$  for bounded  $P$  (resp.  $\Sigma^{HW} \models \text{SN}$ ). This will be used in turn to derive the Standardization and Normalization Theorem for a large class of regular CRS's.

6.2.7.1. As in I.3.9 the set  $L$  of Lévy-labels is defined: there is a set of basic symbols  $L' = \{a, b, c, \dots\}$ , and from these  $L$  is built up by concatenation and underlining, e.g.  $\underline{abca} \in L$ . The function  $h$  denotes the 'height' of  $\alpha \in L$  (i.e. the maximum level of underlining of  $\alpha$ ), e.g.

$$h(\underline{abca}) = 2. \quad (\text{See I.3.9.})$$

In order to define the concept 'degree of a redex', analogous to the one in I.3.9, and to prove that a redex can only create redexes of lesser degree, we need several definitions.

6.2.7.2. RESTRICTION. For technical reasons (see Remark 6.2.7.6) we will consider in this subsection 6.2.7 only CRS's  $\Sigma$  without 'singleton redexes', i.e. if  $H \rightarrow H' \in \text{Red}(\Sigma)$ , then  $H$  is not a constant  $Q$ .

6.2.7.3. DEFINITION. Let  $\Sigma$  be a regular CRS.

(i) The relation  $\subseteq$  ('sub-metaterm') is defined for  $\text{Mter}(\Sigma)$  as for  $\text{Ter}(\Sigma)$  with the extra clause that  $H_i \subseteq Z^n(H_1, \dots, H_n)$ ,  $i = 1, \dots, n$ , for all  $H_i \in \text{Mter}(\Sigma)$  and  $n$ -ary metavariables  $Z^n$ .

(ii) The relation  $\subseteq_\ell$  ('left subterm') on  $\text{Ter}(\Sigma)$  is defined as follows:

(1)  $A \subseteq_\ell (AB)$  where  $(AB)$  is an applicative term,

(2)  $A \subseteq_\ell B \subseteq_\ell C \Rightarrow A \subseteq_\ell C$ .

(Note that  $A \subseteq_\ell B \iff \exists C \vec{A}C \equiv B$ .)

6.2.7.4. DEFINITION. Let  $\Sigma$  be a regular CRS and  $H \in \text{Mter}(\Sigma)$ .

(i) A *proper indexing* (or *proper labeling*) for  $H$  is a map assigning an  $L$ -label to every subterm of  $H$  except  $H$  itself and except the metavariables  $Z$  in  $H$ .

We will use the exponential notation: if  $H \equiv SZ_1Z_2Z_3$ , then e.g.

$H^I \equiv ((S^a Z_1)^b Z_2)^{ab} Z_3$  is  $H$  plus a proper indexing map  $I$ .

(ii) If  $I$  is a proper indexing of  $H$ , then  $(I)$  will denote the  $L$ -label obtained by concatenation of the labels from left to right as they appear in  $H^I$ .

E.g. in the example in (i):  $(I) = \underline{abab}$ . Furthermore  $(\underline{I})$  is  $(I)$  underlined; in our example,  $(\underline{I}) = \underline{abab}$ .

(iii) If  $\alpha \in L$ , then  $\alpha \times H$  denotes a labeling of  $H$  in which every sub-meta-term of  $H$  bears label  $\alpha$ .

E.g. for  $H$  as in (i):  $\alpha \times H \equiv ((S_1^{\alpha} Z_1^{\alpha})^{\alpha} Z_2^{\alpha} Z_3^{\alpha})^{\alpha}$ . And if  $H \equiv Z(I, I)$  for a binary metavariable  $Z$ , then  $\alpha \times H \equiv (Z(I^{\alpha}, I^{\alpha}))^{\alpha}$ ; we will also write  $Z^{\alpha}(I^{\alpha}, I^{\alpha})$ .

6.2.7.5. DEFINITION. Let  $\Sigma$  be a regular CRS. Then  $\Sigma^L$  is the CRS obtained as follows:

- (i)  $\text{Ter}(\Sigma^L) = \{M^I \mid M \in \text{Ter}(\Sigma), I \text{ some } L\text{-labeling of } M\}$   
(ii)  $\text{Red}(\Sigma^L) = \{H^I \rightarrow (\underline{I}) \times H' \mid H \rightarrow H' \in \text{Red}(\Sigma) \ \& \ I \text{ is some proper } L\text{-labeling of } H\}$ .

It is routine to check that  $\Sigma^L$  is a regular CRS again. (In Remark 6.2.7.16 we will mention a more 'economic' variant of  $\Sigma^L$ .)

6.2.7.6. EXAMPLE. (i) Let  $\Sigma$  be  $\{IZ \rightarrow Z, \emptyset Z \rightarrow ZZ\}$ ; then  $\Sigma^L = \{I^{\alpha}Z \rightarrow Z^{\alpha}, \emptyset^{\alpha}Z \rightarrow (Z^{\alpha}Z^{\alpha})^{\alpha} \mid \alpha \in L\}$ . An example of reduction in  $\Sigma^L$ :

$$\begin{array}{ccc}
 \mathcal{D}^a(I^b \emptyset^c)^d & \xrightarrow{\quad} & ((I^b \emptyset^c) \underline{da} (I^b \emptyset^c) \underline{da})^a \\
 \downarrow & & \downarrow \\
 \mathcal{D}^a(\emptyset^{cbda}) & \xrightarrow{\quad} & (\emptyset^{cbda} \underline{da} (I^b \emptyset^c) \underline{da})^a \\
 \downarrow & & \downarrow \\
 \mathcal{D}^a(\emptyset^{cbda}) & \xrightarrow{\quad} & (\emptyset^{cbda} \underline{\emptyset^{cbda}})^a
 \end{array}$$

(ii)  $(\text{CL} \otimes \text{Pairing})^L$  has the rules:

$$((S^{\alpha} Z_1)^{\beta} Z_2)^{\gamma} Z_3 \rightarrow (Z_1^{\underline{d}} Z_3^{\underline{d}})^{\underline{d}} (Z_2^{\underline{d}} Z_3^{\underline{d}})^{\underline{d}} \quad \text{where} \quad \underline{d} = \underline{\alpha\beta\gamma}$$

$$(K^{\alpha} Z_1)^{\beta} Z_2 \rightarrow Z_1^{\underline{\alpha\beta}}$$

$$I^{\alpha} Z \rightarrow Z^{\alpha}$$

$$\mathcal{D}_i^{\alpha}((\emptyset^{\beta} Z_0)^{\gamma} Z_1)^{\delta} \rightarrow Z_1^{\underline{\alpha\beta\gamma\delta}}, \quad i = 0, 1, \quad \text{for all } \alpha, \beta, \gamma, \delta \in L.$$

(iii)  $\lambda^L = \{(\lambda^{\alpha} x. Z_1(x))^{\beta} Z_2 \rightarrow Z_1^{\underline{\alpha\beta}} (Z_2^{\underline{\alpha\beta}}) \mid \alpha, \beta \in L\}$ . If we take  $\alpha$  empty

here (since the symbol  $\lambda$  is in 'usual'  $\lambda$ -calculus not a subterm, it should have no label), we find again  $\lambda^L$  of I.3.9.

6.2.7.6.1. REMARK. (i) A reason to exclude the outermost label  $\alpha$  of a redex in the definition of labeled reduction, is that this allows us to treat the labels in an associative way, i.e. we can make now the identification  $(A^\alpha)^\beta \equiv A^{\alpha\beta}$ , as in the preceding example. Otherwise labeled reduction would be ambiguous; consider e.g. the rule  $\mathcal{D}Z \rightarrow ZZ$  then we would have as corresponding L-reductions:  $(\mathcal{D}^\alpha Z)^\beta \rightarrow Z^{\alpha\beta} Z^{\alpha\beta}$ . However, then

$$\begin{array}{ccc} ((\mathcal{D}^\alpha_x)^\beta)^\gamma & \longrightarrow & (x^{\alpha\beta} x^{\alpha\beta})^\gamma \\ \parallel? & & \parallel \\ (\mathcal{D}^\alpha_x)^\beta \gamma & \longrightarrow & x^{\alpha\beta\gamma} x^{\alpha\beta\gamma} \end{array}$$

(ii) For the same reason we have excluded 'singleton redexes'; because there the outermost label has to be taken into account if one wants Lemma 6.2.7.12. However, an extension of the results of this subsection to the case where singleton redexes are present, is possible, at the cost of the associativity in the manipulation of labels as in (i).

We will now define another kind of term formation tree than used so far (see Def. 1.7) and which has the advantage that there is a bijection between the nodes of the tree  $\tau'(M)$  and the occurrences of subterms in the term  $M$ .

6.2.7.7. DEFINITION. The term formation tree  $\tau'(M)$  of  $M \in \text{Ter}(\Sigma)$  is inductively defined as follows:

(i)  $\tau'(s) = s$  if  $s \equiv Z, \Omega, x$

(ii)  $\tau'(AB) =$

$$\begin{array}{c} \diagup \quad \diagdown \\ \tau'(A) \quad \tau'(B) \end{array}$$

(iii)  $\tau'([x]A) = [x]$

$$\begin{array}{c} | \\ \tau'(A) \end{array}$$

EXAMPLE.  $\tau^1((\lambda x.xxxx)yz) =$

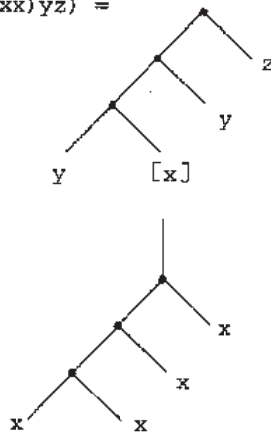

6.2.7.8. DEFINITION. Let  $\Sigma^L$  be an L-labeled CRS. Let  $H \rightarrow H' \in \text{Red}(\Sigma)$  and  $H^I \rightarrow (I) \times H$  be a rule in  $\Sigma^L$ . Let  $R \equiv \rho(H^I)$  be a  $\Sigma^L$ -redex.

Then the *degree* of  $R$  is  $(I)$ .

6.2.7.9. EXAMPLE. (i) The degree of  $((S^a A)^\beta B)^\gamma C)^\delta$  is  $\alpha\beta\gamma$ .

(ii) Consider in  $(\text{CL} \oplus \text{Pairing})^L$  the term  $M \equiv$

$$(((S^a I^b)^c ((K^d (I^e I^f) g) h) i) j) k (D_0^l ((D^m K^n) O I^p) q) r) s.$$

Here the  $S$ -redex has degree  $ack$ , the  $K$ -redex  $dh$ , the  $I$ -redex  $e$ , and the  $D_0$ -redex  $lmoq$ . In tree notation:

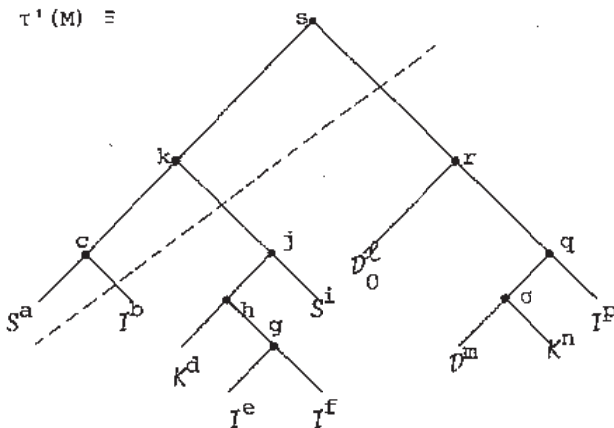

6.2.7.10. DEFINITION. Let  $\Sigma$  be a regular TRS and  $r = H \rightarrow H' \in \text{Red}(\Sigma)$ ; say  $H$  contains the metavariables  $Z_1, \dots, Z_n$ . Let  $R \equiv \rho H$  be an  $r$ -redex for some valuation  $\rho$ .

(i) Then every subterm  $S \subseteq \rho Z_i$  (for some  $i = 1, \dots, n$ ) is called an *internal* subterm of  $R$ . Notation:  $S \subseteq_i R$ . All other subterms  $S'$  of  $R$  are *external*. Notation:  $S' \subseteq_e R$ . We will separate internal and external subterms in  $\tau'(R)$  by a bar; e.g. as in  $\tau'(M)$  above.

Another example: if  $H \equiv O_0(O_1 O_2 Z_0)Z_1(O_3(O_4 Z_2 Z_3))Z_4$ , then  $\tau'(\rho H) =$

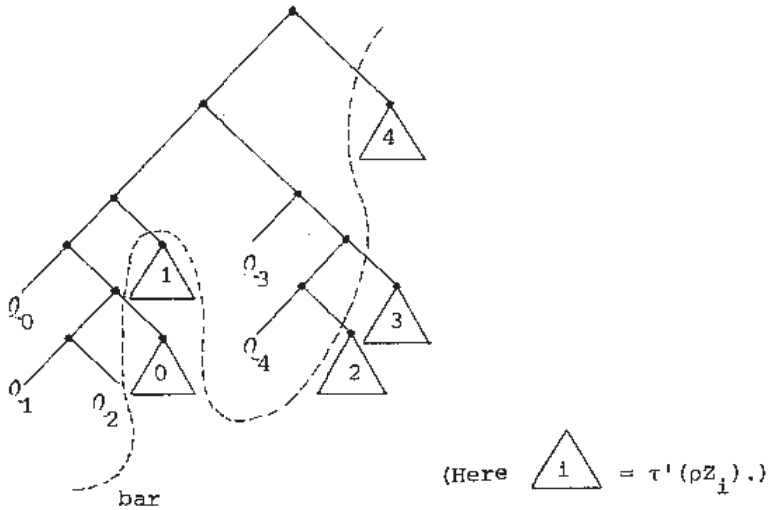

(ii) If  $\rho H$  is labeled, then the label of an internal (external) subterm will be called an internal (external) label of  $\rho H$ . E.g. in  $\tau'(M)$  above,  $a, c, k, s$  are the external labels.

6.2.7.11 PROPOSITION. Let  $R = \rho H$  be a redex. Then:

- (i)  $B \subseteq_e R \iff B$  has a constant occurring in  $H$  as head symbol.  
 (ii)  $A \subseteq_\ell B \subseteq_e R \Rightarrow A \subseteq_e R$ .

PROOF. (i) Routine; (ii) immediately from (i).  $\square$

6.2.7.12. LEMMA. (i) Let  $M_1 \rightarrow M_2$  be a reduction step in  $\Sigma^L$  where  $\Sigma$  is a regular TRS. Let  $R_1 \subseteq M_1, R_2 \subseteq M_2$  be redexes having degrees  $d_1$  resp.  $d_2$ . Then:

- (1)  $R_1 \xrightarrow{\dots} R_2 \Rightarrow d_1 = d_2$  (descendants have the same degree)  
 (2)  $R_1 \xrightarrow{\dots} R_2 \Rightarrow h(d_1) < h(d_2)$  (created redexes have lesser degree).

(ii) As (i), for  $\Sigma = \lambda \oplus \Sigma'$ , where  $\Sigma'$  is a regular TRS.

PROOF. (i) The proof of (1) is routine.

Proof of (2): let  $R_1^C$  be the contractum of  $R_1$  in  $M_2$ . We distinguish two cases.

CASE 1.  $R_1^C \subseteq R_2$ . Consider  $\tau'(R_2)$  as in the figure. (We will identify  $\tau'(M)$  and  $M$  in the remainder of this proof.)

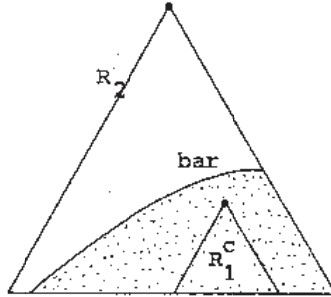

Here all internal subterms of  $R_2$  are below the bar. We claim that  $R_1^C$  cannot be below the bar. For, if it was, then the upper part (above the bar) of  $R_2$  would clearly be unaffected by the reduction step  $M_1 \rightarrow M_2$ , so  $R_2$  would be a descendant of a redex in  $M_1$ , in contradiction with the assumption that  $R_2$  was created in the step  $M_1 \rightarrow M_2$ . Hence  $R_1^C \subseteq_e R_2$  as in the next figure:

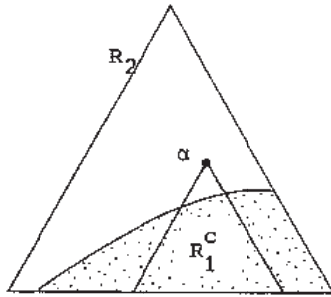

Now consider the label  $\alpha$  of the top node of  $R_1^C$ : this is an external label of  $R_2$ . Now  $\alpha = \underline{(I)}$  where  $(I)$  is the degree of  $R_1$ , by Def.6.2.7.5 of labeled reduction. So the degree of  $R_2$  (the concatenation of all external labels except that of the top node) contains  $\underline{(I)}$ , whence the result follows; except possibly in the case that the tops of  $R_2$  and  $R_1^C$  coincide, i.e.  $R_2 \equiv R_1^C$ .

Suppose this is the case. By restriction 6.2.7.2,  $R_2$  is not a constant - hence  $R_2 \equiv R_1^C$  is an applicative term  $AB$ . By Proposition 6.2.7.11.(ii),

$A \subseteq_e R_2$ . The label of  $A$  is again  $(\underline{I})$ , and this is an external label of  $R_2$  below the top node. Hence the result follows as above.

CASE 2.  $R_2 \subseteq R_1^C$ . Let  $R_1$  be an  $r$ -redex where  $r = H \rightarrow H'$ ; say  $R_1 \equiv \rho H$  for a valuation  $\rho$ . Evidently, there is a submetaterm  $J \subseteq H'$  such that  $R_2 \equiv \rho J$ .  $J$  must be applicative; for  $J \equiv \Omega \equiv R_2$  is impossible by the restriction to non-singleton redexes, and  $J \equiv Z$  is impossible since then  $R_2$  would not be a created redex. So  $J \equiv J_1 J_2$ ; by definition of labeled reduction,  $\rho J_1$  has label  $(\underline{I})$  where  $(I)$  is the degree of  $R_1$ . By Proposition 6.2.7.11.(i) this label is external for  $R_2$  and obviously it is not the top label of  $R_2$ . So again the degree of  $R_2$  contains  $(\underline{I})$ .

(ii) When  $\lambda$  is included, we can distinguish four cases:

1.  $R_1, R_2$  are both  $\beta$ -redexes
2.  $R_1, R_2$  are both TRS-redexes
3. only  $R_1$  is a  $\beta$ -redex
4. only  $R_2$  is a  $\beta$ -redex.

Case 1 is already considered in I.3.9; case 2 is considered in (i) and that the lemma holds for cases 3,4 follows by a reasoning very similar to that in (i).  $\square$

6.2.7.13. Let  $\Sigma$  be a regular CRS. Then  $\Sigma^{L,P}$ , where  $P$  is a predicate on  $L$ , is defined similar to  $\lambda^{L,P}$  in I.3.9.

Also as in I.3.7 and I.3.9 we can define  $\Sigma^{HW}$ , a 'homomorphic image' of  $\Sigma^{L,P}$ .

E.g.  $CL^{HW}$  has the rules:

$$((S^{n+1}Z_1)^{m+1}Z_2)^{k+1}Z_3 \longrightarrow (Z_1^{\ell}Z_3^{\ell})^{\ell}(Z_2^{\ell}Z_3^{\ell})^{\ell}$$

where  $\ell = \min(n,m,k)$ , for all  $n,m,k \in \mathbb{N}$ .

So for  $\Sigma^{HW}$ , Lemma 6.2.7.12 says that descendants keep the same degree as their ancestor redex, and created redexes have a degree less than that of the creator redex.

6.2.7.14. EXAMPLE. In  $(CL \oplus \text{Pairing})^{HW}$ , consider the step

$$D_0^7((K^5D)^3IAB) \rightarrow D_0^7(D^2AB),$$

where all unmentioned labels are high ( $>7$ ). Then the redex  $KDI$  of degree  $\min(5,3)$  has created the  $\mathcal{V}_0$ -redex of degree  $\min(7,2)$ .

6.2.7.15. COROLLARY. If  $\Sigma$  is a regular TRS, or  $\Sigma = \lambda \oplus \Sigma'$  where  $\Sigma'$  is a regular TRS, then:  $\Sigma^{L,P}$  (for  $P$  bounded)  $\models$  SN and  $\Sigma^{HW} \models$  SN.

PROOF. Immediate by Lemma 6.2.7.12 and Theorem 6.2.4.  $\square$

6.2.7.16. REMARK. (i) The preceding corollary can be generalized to the class of all regular CRS's. It is rather tedious to generalize Lemma 6.2.7.12, however.

(ii) It is possible to use a more economic version of  $\Sigma^L$  and  $\Sigma^{HW}$ , in which in  $\alpha \times H$  not every subterm of  $H$  bears the label  $\alpha$ , but only the 'initial' subterms in some sense. We will not elaborate this possibility, but merely mention this more economic version for CL (cf. 6.2.7.13):  $(CL^{HW})'$  has the rules

$$\begin{aligned} ((S^{n+1}z_1)^{m+1}z_2)^{k+1}z_3 &\longrightarrow z_1^\ell z_3 (z_2^\ell z_3) && \text{where } \ell = \min(n,m,k) \\ (K^{n+1}z_1)^{m+1}z_2 &\longrightarrow z_1^{\min(n,m)} \\ I^{n+1}z &\longrightarrow z^n. \end{aligned}$$

It is not hard to check Lemma 6.2.7.12 for  $(CL^{HW})'$ .

6.2.8. As an application of the preceding corollary, we will derive the Standardization and Normalization theorem for a restricted class of  $(\lambda \oplus)$  regular TRS's, which will be defined now.

6.2.8.1. DEFINITION. Let  $\Sigma$  be a regular CRS and  $r \in \text{Red}(\Sigma)$ ;  $r = H \rightarrow H'$ .

- (i) The rule  $r$  is called *left-normal* iff in  $H$  all constants  $Q$  precede the metavariables  $Z$ .
- (ii)  $\Sigma$  is called *left-normal* iff all its rules are left-normal.

6.2.8.2. EXAMPLE. (i)  $\lambda$ , CL and all definable extensions of  $\lambda$  are left-normal.

- (ii)  $\lambda \oplus$  Pairing  $\oplus$  Definition by cases  $\oplus$  Iterator as in Example 1.15.(3) is left-normal.
- (iii) The 'proof-theoretic' reduction rule in Example 1.12.(v) is left-normal.



- (iv) The rules for the recursor  $R$  as in Example 1.12(ii) are not left-normal. However, the (proof-theoretically equivalent) rules for  $R$  as follows:  
 $R\Omega z_1 z_2 \rightarrow \dots, R(Sz_0)z_1 z_2 \rightarrow \dots$  are left-normal.
- (v) Church's generalized  $\delta$ -rules are left-normal (trivially).
- (vi) The rules for the combinator  $F$  in 5.11. Ad(3) are typically non-left-normal.

Our definition of 'standard reduction' for a regular CRS is analogous to the one for  $\lambda$  (and definable extensions), see Def.I.9.1. This definition deviates from the definition of 'standard' for regular TRS's in LÉVY-HUET [79], where Standardization is proved for all regular TRS's. Below we will prove Standardization and Normalization for  $(\lambda\theta)$  regular left-normal TRS's; and on the intersection of those classes our definition is equivalent with the one of Lévy and Huet (we will not prove this).

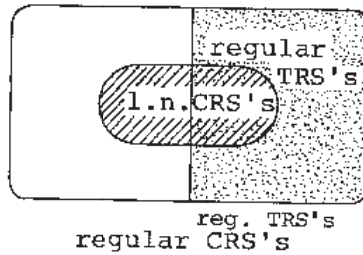

For left-normal CRS's the definition of 'standard' and of the standardization procedure is very simple. Just as in I.10, all we have to do is to permute adjacent reduction steps which form an 'anti-standard pair'.

6.2.8.3. DEFINITION. (i) Let  $\mathcal{R} = M_0 \xrightarrow{R_0} M_1 \xrightarrow{R_1} \dots$  be a  $\Sigma$ -reduction, where  $\Sigma$  is a regular CRS.

In the step  $M_i \xrightarrow{R_i} M_{i+1}$  ( $i \geq 0$  as far as defined), attach a marker  $*$  to all the redex-head-symbols  $Q$  to the left of the head-symbol of  $R_i$ . These markers are persistent, once they are attached (i.e. descendants keep the marker).

Then  $\mathcal{R}$  is *standard*, iff no marked redex is contracted.

(ii) An *anti-standard pair* of reduction steps is a reduction of two steps which is not standard.

(iii) If  $\mathcal{R} = M_0 \rightarrow M_1 \rightarrow M_2$  is an anti-standard pair, we define the "meta-reduction"  $\mathcal{R} \Rightarrow \mathcal{R}'$  analogous to Def.10.2.1.

E.g. if  $\mathcal{R} = \mathcal{D}_0(\mathcal{D}(KII)I) \longrightarrow \mathcal{D}_0(\mathcal{D}II) \longrightarrow I$  (not standard) then  
 $\mathcal{R} \Rightarrow \mathcal{R}' = \mathcal{D}_0(\mathcal{D}(KII)I) \longrightarrow KII \longrightarrow I$  (standard).

6.2.8.4. REMARK. The difference with (definable extensions of)  $\lambda$  is that now redexes can be created whose head-symbol is to the left of that of the creator redex; e.g. as in  $\mathcal{D}_0(I\mathcal{D}AB) \longrightarrow \mathcal{D}_0(\mathcal{D}AB)$ .

6.2.8.5. LEMMA. Let  $\Sigma$  be a regular TRS or let  $\Sigma = \lambda \oplus \Sigma'$  where  $\Sigma'$  is a regular TRS. Then the meta-reduction  $\Rightarrow$  of  $\Sigma$ -reductions is a-cyclic and moreover SN.

PROOF. Analogous to the proofs of Proposition I.10.2.3 and Theorem I.10.2.4.(i), using Corollary 6.2.7.15.  $\square$

6.2.8.6. REMARK. (i) So every  $\Sigma$ -reduction  $\mathcal{R}$ , for  $\Sigma$  as in the lemma, has a  $\Rightarrow$ -normal form; however,  $\mathcal{R}$  may have more than one  $\Rightarrow$ -normal form. Example:

$$\Sigma = \{PzQ \longrightarrow zZ, R \longrightarrow S, IZ \longrightarrow Z\},$$

and

$$\mathcal{R} = PR(IQ) \longrightarrow PRQ \longrightarrow PSQ \longrightarrow SS.$$

Now  $\mathcal{R}$  contains two anti-standard pairs, and

$$\mathcal{R} \Rightarrow PR(IQ) \longrightarrow PRQ \longrightarrow RR \longrightarrow SR \longrightarrow SS = \mathcal{R}_1$$

$$\mathcal{R} \Rightarrow PR(IQ) \longrightarrow PS(IQ) \longrightarrow PSQ \longrightarrow SS = \mathcal{R}_2$$

where  $\mathcal{R}_1, \mathcal{R}_2$  are both  $\Rightarrow$ -normal forms.

(ii) Moreover, an  $\Rightarrow$ -normal form is not necessarily a standard reduction; e.g.  $\mathcal{R}_1$  is not standard. If the last step of  $\mathcal{R}_1$  is omitted, we have a reduction which is not standard and for which there is no standard reduction at all. I.e. for regular CRS's in general, the Standardization Theorem fails. This observation is due to HINDLEY [78], who gives essentially the same counterexample for  $\lambda \oplus$  Recursor  $\mathcal{R}$ , where the rules for  $\mathcal{R}$  are the non-left-normal ones (see Example 6.2.8.2.(iv)).

However:

6.2.8.7. LEMMA. For left-normal regular CRS's  $\Sigma$ : the  $\Sigma$ -reduction  $\mathcal{R}$  is

standard  $\Leftrightarrow \mathcal{R}$  is a  $\Rightarrow$ -normal form.

PROOF. Claim. Let  $\Sigma$  be a left-normal regular CRS. Then the following can not happen.

$$\begin{array}{c}
 M \equiv \overline{\quad \quad \quad \overset{Q_0}{\quad} \quad \overset{Q_1}{\quad} \quad \quad} \\
 \downarrow \overset{Q_1}{\quad} \\
 N \equiv \overline{\quad \quad \quad \overset{Q_2}{\quad} \quad \overset{Q_0^*}{\quad} \quad \quad}
 \end{array}$$

$M \rightarrow N$  is a  $\Sigma$ -reduction step,  $Q_0, Q_1 \in M$  are redex-head symbols such that  $Q_0 < Q_1$  ( $Q_0$  is to the left of  $Q_1$ ). After contraction of  $Q_1$  (i.e. the redex headed by  $Q_1$ ),  $Q_0$  is marked as  $Q_0^*$  in  $N$  (as in Def.6.2.8.3 of 'standard') Moreover, the  $Q_1$ -contraction has created a redex headed by  $Q_2$  such that  $Q_2 < Q_0^*$ .

So what we claim is that no redex to the left of a marked redex can be 'activated' (created). (Note however that in Remark 6.2.8.6 this does happen, in the step  $PR(IQ) \rightarrow PRQ$ . Here  $Q_0 \equiv R$ ,  $Q_1 \equiv I$ ,  $Q_2 \equiv P$ .)

Proof of the claim. Obviously the step  $M \rightarrow N$  must have the form

$$\begin{array}{c}
 M \equiv \text{-- } (Q_2 \dots (Q_0^{\vec{A}}) \dots (Q_1^{\vec{B}}) \dots) \text{--} \\
 \downarrow \\
 N \equiv \text{-- } (Q_2 \dots (Q_0^{\vec{A}^*}) \dots (Q_3^{\vec{C}}) \dots) \text{--}
 \end{array}$$

where

$$(Q_2 \dots (Q_0^{\vec{A}^*}) \dots (Q_3^{\vec{C}}) \dots)$$

is an  $r$ -redex, such that the LHS of the rule  $r$  is  $(Q_2 \dots Z \dots (Q_3^{\vec{H}}) \dots)$ . That  $Q_0^{\vec{A}^*}$  must be in fact a subterm of  $\rho Z$ , follows from the non-ambiguity of the rules, in casu  $r$  (see also Def.1.14). However, a left-normal CRS cannot have a rule  $r$  as displayed, since  $Q_3$  should precede the meta-variable  $Z$ . This proves the claim.

Now we can prove the assertion in the lemma, by induction on  $|\mathcal{R}|$ , the number of steps in  $\mathcal{R}$ . Here  $(\Rightarrow)$  is trivial.  $(\Leftarrow)$ :

Basis.  $|\mathcal{R}| = 2$ : trivial.

Induction step. Suppose for  $|\mathcal{R}| = n$  the assertion is proved. Now let  $\mathcal{R} = M_0 \longrightarrow \dots \longrightarrow M_{n+1}$  be a reduction of  $n+1$  steps, and suppose  $\mathcal{R}$  is a  $\Rightarrow$ -normal form, but nevertheless not standard. By induction hypothesis we know that  $M_0 \longrightarrow \dots \longrightarrow M_n$  and  $M_1 \longrightarrow \dots \longrightarrow M_{n+1}$  are standard. So  $\mathcal{R}$  must be of the following form:

$$\begin{array}{c}
 M_0 \equiv \frac{Q_0 \quad Q_1}{\hline} \\
 \downarrow Q_1 \\
 M_1 \equiv \frac{Q_2 \quad Q_0^*}{\hline} \\
 \downarrow Q_2 \\
 M_2 \\
 \vdots \\
 M_n \equiv \frac{Q_0^*}{\hline} \\
 \downarrow Q_0 \\
 M_{n+1}
 \end{array}$$

In  $M_n \longrightarrow M_{n+1}$  for the first time a marked redex  $Q_0^*$  is contracted (otherwise  $M_0 \longrightarrow \dots \longrightarrow M_n$  was not standard).

The ancestor of this redex must have been marked already by the first step in  $\mathcal{R}$ ; otherwise  $M_1 \longrightarrow \dots \longrightarrow M_{n+1}$  was not standard. So in  $M_0 \longrightarrow M_1$  a redex  $Q_1 > Q_0$  is contracted, marking  $Q_0$ . Now in  $M_1 \longrightarrow M_2$  a redex  $Q_2 < Q_0^*$  must have been contracted, for if  $Q_2 > Q_0^*$  then  $Q_2$  marks  $Q_0$  again and  $M_1 \longrightarrow \dots \longrightarrow M_{n+1}$  would be not standard. Now  $Q_2$  must have been created by  $Q_1$ , otherwise it was marked by  $Q_1$ , and  $M_0 \longrightarrow \dots \longrightarrow M_n$  was not standard.

But that is the situation which cannot occur, according to the claim. Hence  $\mathcal{R}$  is standard and the lemma is proved.  $\square$

So by the preceding two lemma's we have now:

**6.2.8.8. THEOREM** (Standardization for left-normal regular TRS's).

Let  $\Sigma$  be a left-normal regular TRS, or let  $\Sigma = \lambda \oplus \Sigma'$  where  $\Sigma'$  is a left-normal regular TRS. Then for every  $\Sigma$ -reduction  $\mathcal{R} = M_0 \longrightarrow \dots \longrightarrow M_n$  there is a standard reduction  $\mathcal{R}_{st} = M_0 \longrightarrow \dots \longrightarrow M_n$ .  $\square$

We conclude this Chapter with a corollary of the Standardization Theorem. The proof is entirely analogous to that of Theorem I.11.2:

6.2.8.9. THEOREM (Normalization for left-normal regular TRS's)

Let  $\Sigma$  be as in 6.2.8.8. Then repeated contraction of the leftmost redex in a  $\Sigma$ -term leads to the normal form, if it exists.  $\square$

6.2.8.10. REMARK. (i) It is possible to extend these results to the class of all regular left-normal CRS's. (Cf. remark 6.2.7.16.(i).)

(ii) Also we expect that one can prove moreover the strong version of the Standardization Theorem for regular left-normal CRS's, analogous to Theorem I.10.2.8.(iii).

## CHAPTER III

## IRREGULAR COMBINATORY REDUCTION SYSTEMS

After having occupied ourselves in Chapters I and II exclusively with regular CRS's, where 'regular' is short for 'left-linear and non-ambiguous' (Def.II.1.11, II.1.14), we will consider some irregular CRS's now. We will mainly study the effect of dropping the left-linearity condition; only in one instance (viz.  $\lambda \oplus$  Surjective Pairing) an ambiguous CRS will be considered here. (For results about ambiguous TRS's, see e.g. HUET [78].)

In section 1 we will prove that the CR property fails for some non-left-linear CRS's. In section 2 an 'intuitive' explanation of this failure is given, with the aid of 'infinite expansions' of terms (Böhm trees). Finally some positive results about the CRS's in question are given.

## 1. COUNTEREXAMPLES TO THE CURCH-ROSSER PROPERTY

1.1. Consider  $\lambda$ -calculus  $\oplus$  constants  $\mathcal{D}, \mathcal{D}_0, \mathcal{D}_1$  and reduction rules

$$\begin{aligned} r_0: \mathcal{D}_0(\mathcal{D}z_0z_1) &\longrightarrow z_0 \\ r_1: \mathcal{D}_1(\mathcal{D}z_0z_1) &\longrightarrow z_1 \\ r: \mathcal{D}(\mathcal{D}_0z)(\mathcal{D}_1z) &\longrightarrow z. \end{aligned}$$

The 'meaning' of the constants is that they constitute a *Surjective Pairing* (SP): from the pair  $\mathcal{D}z_0z_1$  one obtains the first resp. second coordinate by applying  $\mathcal{D}_0$  resp.  $\mathcal{D}_1$ ; the third rule gives the surjectivity, in the sense that w.r.t. the equality  $=$ , generated by  $\longrightarrow$ , every term is a pair:  $A = \mathcal{D}(\mathcal{D}_0A)(\mathcal{D}_1A)$ .

It was asked by Colin Mann (1972) (see BARENDREGT [74]) whether this CRS,  $\lambda \oplus$  SP, has the CR property. Note that  $\lambda \oplus$  SP is non-left-linear (in rule  $r$ ) as well as ambiguous: there are the interferences  $r \not\leq r_0$  (see Def.II.1.14) as shown by the term  $\mathcal{D}_0(\mathcal{D}(\mathcal{D}_0A)(\mathcal{D}_1A))$ , likewise  $r \not\leq r_1$ , and

moreover  $r_0, r_1 \leq r$  as shown by  $\mathcal{D}(\mathcal{D}_0(\mathcal{DAB})) (\mathcal{D}_1(\mathcal{DAB}))$ .

These ambiguities, however, do not spoil the property WCR:

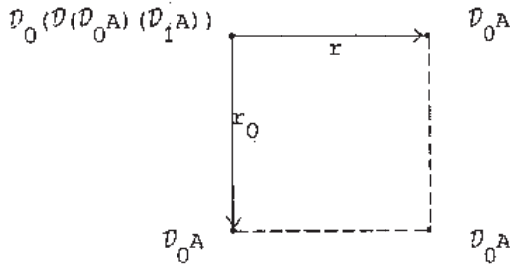
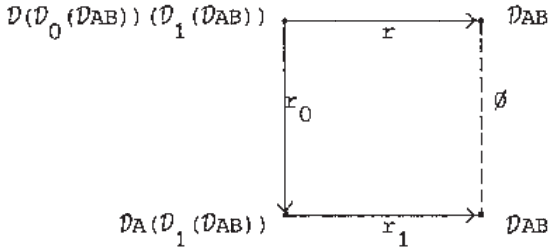

Likewise the lack of left-linearity is no obstacle to WCR:

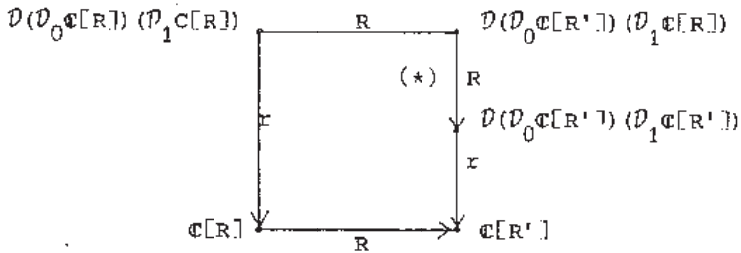

Here the 'disturbance' of the  $r$ -redex by the contraction of redex  $R$  to  $R'$  is compensated by the 'mirrored' contraction of  $R$  in the step (\*).

In attempts to prove that  $\lambda \oplus SP \models CR$ , it seems that the essential problem is the non-left-linearity, rather than the ambiguity of the rules. Therefore R. Hindley considered  $\lambda \oplus$  the constant  $\mathcal{D}_h$  with the reduction

rule

$$\mathcal{D}_h ZZ \rightarrow Z$$

and posed the question whether  $\lambda \oplus \mathcal{D}_h \models \text{CR}$  holds (cf. the problem list BARENDREGT [75]). A further simplification of the question was made by STAPLES [75], who considered  $\lambda \oplus$  the constant  $\mathcal{D}_s$  with the rule

$$\mathcal{D}_s ZZ \rightarrow E$$

where  $E$  is some 'inert' constant. In the sequel we will consider yet another variant, namely  $\lambda \oplus \mathcal{D}_k$  and the rule

$$\mathcal{D}_k ZZ \rightarrow Ez$$

with a similar  $E$  as before. The CR-problem for this CRS is so to speak intermediate between the last two, and moreover the use of  $\lambda \oplus \mathcal{D}_k$  will prove to have certain technical advantages.

G. Huet and J.J. Levy remarked (personal communication) that one encounters a similar CR-problem when considering Recursive Program Schemes (see I.1.13) with the branching operation 'if P then A else B' and apart from the usual rules for this operation also the rule

$$\underline{\text{if P then Z else Z}} \rightarrow Z.$$

The same CR-problem was posed in the list of "Further Research" topics in O'DONNELL [77].

Finally, we mention that the CR-problem for non-left-linear extensions of  $\lambda$ -calculus is also encountered in foundational studies, see FEFERMAN [80].

1.2. Before describing the underlying 'intuition' in the next subsection, we will first prove that CR fails for the CRS's mentioned in 1.1.

1.2.1. As an introductory example, consider the TRS  $\Sigma_s$  consisting of the constants  $A, C, \mathcal{D}_s, E$  and the rules



$$\begin{aligned} DZZ &\longrightarrow E \\ Cz &\longrightarrow DZ(Cz) \\ A &\longrightarrow CA \end{aligned}$$

(we will drop the subscript in  $D_s$  sometimes).

Now we have the following reductions:

$$\begin{array}{c} A \longrightarrow CA \longrightarrow DA(CA) \longrightarrow D(CA)(CA) \longrightarrow E \\ \quad \downarrow \\ \quad C(CA) \\ \quad \downarrow \\ \quad C(DA(CA)) \\ \quad \downarrow \\ \quad C(D(CA)(CA)) \\ \quad \downarrow \\ \quad CE \end{array}$$

So in order to have  $\Sigma_s \models CR$ , the terms  $CE$  and  $E$  must have a common reduct. First some notation:

1.2.1.1. NOTATION. Let  $M, N \in \text{Ter}(\Sigma)$  for some CRS  $\Sigma$ . Then  $M \downarrow N$  will mean:  $\exists L \ M \longrightarrow L \longleftarrow N$ .

Now obviously,  $CE \downarrow E$  iff  $CE \longrightarrow E$ . However, the only reduction of  $CE$  is:

$$CE \longrightarrow DE(CE) \longrightarrow DE(DE(CE)) \longrightarrow DE(DE(DE(CE))) \longrightarrow \dots, \text{ hence } CE \not\rightarrow E.$$

Therefore  $\Sigma_s \not\models CR$ .

1.2.2. For the TRS  $\Sigma_k$  consisting of constants  $A, B, D_k, E$  and rules

$$\begin{aligned} D_k ZZ &\longrightarrow EZ \\ Cz &\longrightarrow DZ(Cz) \\ A &\longrightarrow CA \end{aligned}$$

We have an analogous counterexample to CR:

$$\begin{array}{ccccccc}
 A & \longrightarrow & CA & \longrightarrow & DA(CA) & \longrightarrow & D(CA)(CA) \longrightarrow E(CA) \\
 & & \downarrow & & & & \\
 & & C(E(CA)) & & & & 
 \end{array}$$

(where the downward reduction is again the horizontal one preceded by C) and now  $E(CA) \not\rightarrow C(E(CA))$ , as some calculations make plausible and as will be proved later on.

1.2.3. The counterexamples to CR for the above TRS's  $\Sigma_s, \mathcal{D}_k$  carry over almost immediately to  $\lambda \oplus \mathcal{D}_s$  and  $\lambda \oplus \mathcal{D}_k$ , as follows.

For  $\lambda \oplus \mathcal{D}_s$  resp.  $\lambda \oplus \mathcal{D}_k$ , let  $E$  be either a new constant or some free variable, or put  $E \equiv (\lambda x.xx)(\lambda x.xx)$ . Let

$$\begin{array}{l}
 C \equiv Y_T \lambda cz. \mathcal{D}_s z(cz) \text{ resp. } Y_T \lambda cz. \mathcal{D}_k z(cz) \\
 A \equiv Y_T C
 \end{array}$$

where  $Y_T \equiv (\lambda ab.b(aab))(\lambda ab.b(aab))$  is Turing's fixed point combinator as introduced in I.1.11 (Here we prefer  $Y_T$  to Curry's fixed point combinator  $Y \equiv \lambda a.((\lambda b.a(bb))(\lambda b.a(bb)))$  since  $Y_T M \longrightarrow M(Y_T M)$  for all  $M$  but not  $YM \longrightarrow M(YM)$ .)

Now as in 1.2.1 and 1.2.2 we have in both cases:

$$\begin{array}{l}
 CM \longrightarrow DM(CM) \\
 A \longrightarrow CA
 \end{array}$$

and hence as above:

$$\begin{array}{ccc}
 A \longrightarrow CA \longrightarrow E & \text{resp.} & A \longrightarrow CA \longrightarrow E(CA) \\
 \downarrow & & \downarrow \\
 CE & & C(E(CA))
 \end{array}$$

1.2.4. Before proving that  $CE \not\rightarrow E$  resp.  $C(E(CA)) \not\rightarrow E(CA)$ , i.e. that  $\lambda \oplus \mathcal{D}_s \not\models CR$  resp.  $\lambda \oplus \mathcal{D}_k \not\models CR$ , we will state CR-counterexamples for  $\lambda \oplus \mathcal{D}_k$  ZZ  $\rightarrow$  Z and  $\lambda \oplus$  Surjective Pairing.

Note here that for  $\lambda \oplus \mathcal{D}_h$  it does not work to define A,C such that

$$CM \twoheadrightarrow \mathcal{D}M(CM)$$

$$A \twoheadrightarrow CA$$

since now the reductions analogous to the ones above:

$$\begin{array}{c}
 A \twoheadrightarrow CA \twoheadrightarrow \mathcal{D}A(CA) \twoheadrightarrow \mathcal{D}(CA)(CA) \twoheadrightarrow CA \\
 \downarrow \\
 C(CA)
 \end{array}$$

do not provide a CR-counterexample.

The following heuristic consideration shows how one can proceed. There are between the CRS's  $\lambda \oplus \mathcal{D}_k, \mathcal{D}_s, \mathcal{D}_h$ , SP 'interdefinabilities' as in the figure:

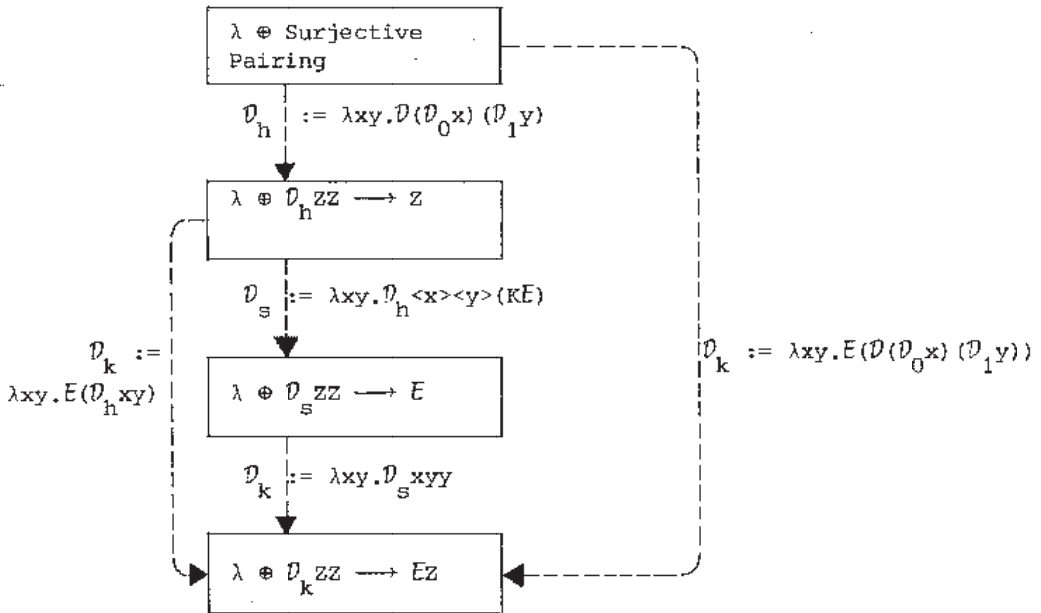

Here we used the notation  $\langle M \rangle \equiv \lambda z.zM$  ( $z \notin FV(M)$ ) and  $KM \equiv \lambda z.M$ .

(Remark: it does not seem possible to reverse any of these  $\twoheadrightarrow$  arrows.)

E.g. in  $\lambda \oplus \mathcal{D}_h ZZ \twoheadrightarrow Z$  we can define the constant  $\mathcal{D}_k$  as  $\lambda xy.E(\mathcal{D}_h xy)$ ; for then we have for all terms  $M$ :

$$\mathcal{D}_k MM \equiv (\lambda xy.E(\mathcal{D}_h xy))MM \twoheadrightarrow \twoheadrightarrow E(\mathcal{D}_h MM) \twoheadrightarrow EM.$$

Now the (claimed) CR-counterexample for  $\lambda \oplus \mathcal{D}_k$  can easily be rewritten, to yield (claimed) CR-counterexamples for the systems which are higher in the above figure. E.g. the terms C,A in  $\lambda \oplus \mathcal{D}_k$  such that  $CM \twoheadrightarrow \mathcal{D}_k M(CM)$  and  $A \twoheadrightarrow CA$  as in 1.2.3 can be defined also in  $\lambda \oplus \mathcal{D}_h$ :

$$C'M \twoheadrightarrow (\lambda xy. E(\mathcal{D}_h xy))M(C'M) \twoheadrightarrow E(\mathcal{D}_h M(C'M))$$

$$A' \twoheadrightarrow C'A'.$$

In fact, let us define in  $\lambda \oplus \mathcal{D}_h$ :

$$C \equiv \lambda cm. E(\mathcal{D}_h m(cm))$$

$$A \equiv \lambda c. C,$$

then we have (somewhat more directly than C',A'):

$$CM \twoheadrightarrow E(\mathcal{D}_h M(CM)) \quad \text{for all } M$$

$$A \twoheadrightarrow CA$$

and now

$$\begin{array}{c} A \twoheadrightarrow CA \twoheadrightarrow E(\mathcal{D}_h A(CA)) \twoheadrightarrow E(\mathcal{D}_h (CA)(CA)) \twoheadrightarrow E(CA) \\ \downarrow \\ C(E(CA)) \end{array}$$

is again the (claimed) CR-counterexample for  $\lambda \oplus \mathcal{D}_h$ .

Similarly we find for  $\lambda \oplus SP$ :

$$CM \twoheadrightarrow E(D(D_0 M)(D_1(CM))) \quad \text{for all } M$$

$$A \twoheadrightarrow CA$$

and reductions

$$\begin{array}{c}
 A \twoheadrightarrow CA \twoheadrightarrow E(\mathcal{D}(\mathcal{D}_0 A) (\mathcal{D}_1 (CA))) \twoheadrightarrow E(\mathcal{D}(\mathcal{D}_0 (CA)) (\mathcal{D}_1 (CA))) \twoheadrightarrow E(CA) \\
 \downarrow \\
 C(E(CA)).
 \end{array}$$

1.2.5. REMARK. (i) Using the interdefinabilities scheme above, one can find some alternative CR-counterexamples, e.g. for  $\lambda \oplus \mathcal{D}_h$ , using the definability of  $\mathcal{D}_s$  in  $\lambda \oplus \mathcal{D}_h$ :  $CM \twoheadrightarrow \mathcal{D}_h \langle M \rangle \langle CM \rangle (KE)$  and  $A \twoheadrightarrow CA$ .  
(ii) Our original construction in KLOP [77] was based on the TRS  $\Sigma$  consisting of constants  $A, B, C, D, E$  and rules

$$\begin{array}{l}
 DZZ \twoheadrightarrow EZ \\
 Cz \twoheadrightarrow Dz(Cz) \\
 A \twoheadrightarrow DAB \\
 B \twoheadrightarrow C(DAB)
 \end{array}$$

Using the abbreviations  $\Delta := DAB$  and  $\square := D\Delta(C\Delta)$ , we have reductions

$$\begin{array}{c}
 \Delta \searrow \\
 \square \equiv D\Delta(C\Delta) \twoheadrightarrow \twoheadrightarrow D\square \twoheadrightarrow E\square \\
 C\Delta \nearrow \\
 \downarrow \\
 D(E\square)(C\Delta) \\
 \downarrow \\
 D(E\square)(C(E\square))
 \end{array}$$

and now  $E\square \not\twoheadrightarrow D(E\square)(C(E\square))$ , as is made plausible by considering that

- (i)  $E\square + D(E\square)(C(E\square)) \Rightarrow E\bar{D} + C(E\bar{\square})$
- (ii)  $C(E\bar{\square}) \twoheadrightarrow D(E\bar{\square})(C(E\bar{\square}))$ .

This TRS can be defined then in  $\lambda \oplus \mathcal{D}_k$  by means of the *multiple* fixed point theorem in I.1.11 (necessary since  $A, B$  are defined in terms of each other).

H.P. Barendregt remarked that this construction could be simplified as in 1.2.2 above, thus requiring for its definition only a *single* fixed point construction.

We will now prove that the claimed CR-counterexamples are indeed counterexamples.

1.2.6. DEFINITION. Let  $\Sigma$  be  $\lambda \otimes \mathcal{D}_k, \mathcal{D}_s, \mathcal{D}_h$  or  $SP$

- (i) We will call a finite  $\Sigma$ -reduction  $\mathcal{R}$  *special* if  $\mathcal{R} = \mathcal{R}_\beta * \mathcal{R}_D$  where  $\mathcal{R}_\beta$  is a standard  $\beta$ -reduction and  $\mathcal{R}_D$  is a sequence of  $\mathcal{D}$ -steps (i.e.  $\mathcal{D}_s, \mathcal{D}_h, \mathcal{D}_k$  or  $\mathcal{D}, \mathcal{D}_0, \mathcal{D}_1$ -steps). Here  $*$  denotes concatenation of reduction sequences.
- (ii) A  $\Sigma$ -conversion  $\Gamma$  is a finite sequence  $\Gamma = M_0 \text{ --- } M_1 \text{ --- } \dots \text{ --- } M_n$  (for some  $n \geq 0$ ) where each --- is either  $\longrightarrow$  or  $\longleftarrow$ . A conversion  $\Gamma$  which is not a reduction, is called *special* if it consists of two converging special reductions  $\mathcal{R}_1, \mathcal{R}_2$ ; i.e.  $\Gamma = M \xrightarrow{\mathcal{R}_1} N \xleftarrow{\mathcal{R}_2} L$  for some  $M, N, L$  and special  $\mathcal{R}_1, \mathcal{R}_2$ .
- Notation:  $\Gamma = \mathcal{R}_1 * \mathcal{R}_2^{-1}$ .

- (iii)  $|\mathcal{R}|$  denotes the total number of symbols in the reduction  $\mathcal{R}$ ; i.e. if  $\mathcal{R} = M_0 \longrightarrow \dots \longrightarrow M_n$  then  $|\mathcal{R}| = \sum_{i=0}^n |M_i|$  where  $|M_i|$  is the length of  $M_i$ .

If  $\Gamma = \mathcal{R}_1 * \mathcal{R}_2^{-1}$ , then  $|\Gamma| = |\mathcal{R}_1| + |\mathcal{R}_2|$ .

1.2.7. PROPOSITION.

- (i)  $\lambda \otimes (\mathcal{D}_s ZZ \longrightarrow E) \models PP_{\beta, \mathcal{D}_s}$
- (ii)  $\lambda \otimes (\mathcal{D}_k ZZ \longrightarrow EZ) \models PP_{\beta, \mathcal{D}_k}$

(I.e. the  $\mathcal{D}$ -steps can be postponed; see Def.1.5.2.(5).)

PROOF. (i) Let  $r$  be the rule  $\mathcal{D}_s ZZ \longrightarrow E$ . Define  $M \xrightarrow{r^{-1}} N$  iff  $N \xrightarrow{r} M$ . According to Proposition I.5.5: if  $\beta$  commutes with  $r^{-1}$ , then  $PP_{\beta, r}$  holds. Now it is easily checked that

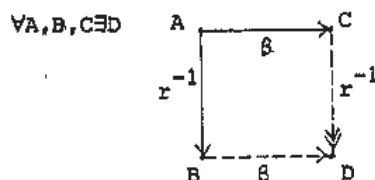

Note that here  $B \xrightarrow{\beta} D$  is one step; hence it follows easily that  $\beta$  and  $r^{-1}$  are indeed commuting.

- (ii) The converse of the rule  $r = \mathcal{D}ZZ \longrightarrow EZ$  is  $r^{-1} = EZ \longrightarrow \mathcal{D}ZZ$ ; and  $A = \lambda \otimes r^{-1}$  is evidently a regular CRS. In fact,  $A$  is a definable extension

of  $\lambda$ -calculus. Therefore, by Corollary I.6.13,  $\beta$  commutes with  $r^{-1}$ . Hence as in (i),  $\lambda \oplus r \Vdash PP_{\beta, \mathcal{D}}$ .  $\square$

1.2.8. THEOREM.  $\lambda \oplus (\mathcal{D}_S Z Z \rightarrow E) \not\vdash CR$ .

PROOF. Consider the reductions  $A \twoheadrightarrow CA \twoheadrightarrow \bar{E}$  as defined in 1.2.3.

$$\begin{array}{c} \downarrow \\ CE \end{array}$$

We claim that  $CE \not\vdash E$ , or equivalently (since  $\bar{E}$  is a normal form), that  $CE \not\twoheadrightarrow \bar{E}$ . For, suppose that  $CE \twoheadrightarrow \bar{E}$ , then, by Proposition 1.2.7(i) and the Standardization Theorem for  $\lambda$ , there is a special reduction  $\mathcal{R}$  from  $CE$  to  $\bar{E}$ . Suppose moreover that  $\mathcal{R}$  is a *minimal* special reduction from  $CE$  to  $\bar{E}$ , in the sense of  $| |$ , as in Def.1.2.6.(iii).

Since  $\mathcal{R}$  is special, it is easy to see that  $\mathcal{R}$  must be of the form

$$\begin{array}{c} \mathcal{R}: CE \equiv \mathcal{Y}_T(\lambda cz. \mathcal{D}_S z(cz))E \\ \downarrow \mathcal{L}, m \\ (\lambda b. b(\mathcal{Y}_T b))(\lambda cz. \mathcal{D}_S z(cz))E \\ \downarrow \mathcal{L}, m \\ (\lambda cz. \mathcal{D}_S z(cz))CE \\ \downarrow \mathcal{L}, m \\ \downarrow \mathcal{L}, m \\ \left. \begin{array}{c} \mathcal{D}_S E(CE) \\ \beta \downarrow \text{standard} \\ \mathcal{D}_S \downarrow \\ \mathcal{D}_S EE \\ \mathcal{D}_S \downarrow \\ E \end{array} \right\} \mathcal{R}' \end{array}$$

(Here  $\xrightarrow{\mathcal{L}, m}$  denotes a 'leftmost' reduction step; i.e. the contracted redex is the leftmost redex of the term.)

However, the reduction  $\mathcal{R}'$ , indicated above, contains in an evident sense a reduction  $\mathcal{R}'': CE \twoheadrightarrow E$ , which is moreover a special reduction. Furthermore  $|\mathcal{R}''| < |\mathcal{R}|$ , contradicting the minimality of  $\mathcal{R}$ .

Hence  $CE \not\twoheadrightarrow E$ .  $\square$

1.2.9. THEOREM.  $\lambda \oplus (D_k ZZ \rightarrow EZ) \neq CR.$

PROOF. Consider the reductions

$$\begin{array}{c} A \twoheadrightarrow CA \twoheadrightarrow E(CA) \\ \downarrow \\ C(E(CA)) \end{array}$$

as defined in 1.2.3. We claim that  $E(CA) \not\downarrow C(E(CA))$ . Suppose not. Then there is a conversion  $\Gamma = \mathcal{R}_1 * \mathcal{R}_2^{-1}$  as follows:

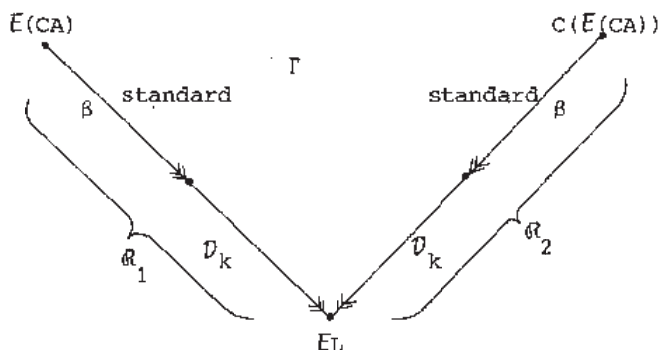

for some term  $L$ . Here we may suppose that  $\mathcal{R}_1, \mathcal{R}_2$  are special reductions (Def.1.2.6), as in the proof of Theorem 1.2.8; so  $\Gamma$  is a special conversion. Now let  $\Gamma$  be moreover a *minimal* (w.r.t.  $\uparrow$ , cf. Def.1.2.6.(iii)) special conversion between  $E(CA)$  and  $C(E(CA))$ . Analogous to the proof of 1.2.8,  $\mathcal{R}_2$  must be of the form

$$\begin{array}{c} C(E(CA)) \\ \beta \downarrow \text{l.m.} \\ D(E(CA)) (C(E(CA))) \\ \beta \downarrow \text{standard} \\ D_k \downarrow \\ D_k L'L' \\ \downarrow \\ EL' \\ \downarrow \\ EL \end{array} \left. \vphantom{\begin{array}{c} C(E(CA)) \\ \beta \downarrow \text{l.m.} \\ D(E(CA)) (C(E(CA))) \\ \beta \downarrow \text{standard} \\ D_k \downarrow \\ D_k L'L' \\ \downarrow \\ EL' \\ \downarrow \\ EL \end{array}} \right\} \mathcal{R}_2$$



But then the above indicated reduction  $\mathcal{R}'$  contains clearly a reduction  $\mathcal{R}'_1: E(CA) \rightarrow L'$  and a reduction  $\mathcal{R}'_2: C(E(CA)) \rightarrow L'$ . That is,  $\mathcal{R}'$  contains a conversion  $\Gamma' = \mathcal{R}'_1 * \mathcal{R}'_2^{-1}$  between the two terms in question. Also it is obvious that  $|\Gamma'| < |\mathcal{R}'_2| \leq |\Gamma|$  and that  $\Gamma'$  is special, contradicting the minimality of  $\Gamma$ .  $\square$

1.2.10. THEOREM.

$$(i) \quad \lambda \oplus (\mathcal{D}_h ZZ \rightarrow Z) \not\vdash CR$$

$$(ii) \quad \lambda \oplus SP \not\vdash CR.$$

PROOF. For the present CRS's we do not have  $PP_{\beta, \mathcal{D}}$  (Postponement of  $\mathcal{D}$ -steps) as before. (E.g. consider  $\mathcal{D}_h III \xrightarrow{\mathcal{D}} II \xrightarrow{\beta} I$ .) However, locally the situation is the same; to be more precise:  $G(CA) \vdash PP_{\beta, \mathcal{D}}$ . Here CA is the term defined in 1.2.4 and the 'reduction graph'  $G(CA)$  is the restriction of the CRS in question to the set of reducts of CA.

For (i) as well as (ii), we will prove that  $G(CA) \not\vdash CR$  using the previous theorem and an isomorphism argument.

(i) Let  $C_k, A_k$  be the terms C, A as defined in 1.2.3 for  $\lambda \oplus \mathcal{D}_k$ , and  $C_h, A_h$  the terms C, A as defined in 1.2.4 for  $\lambda \oplus \mathcal{D}_h$ :

$$C_k \equiv Y_T \lambda cz. \mathcal{D}_k z(cz) \quad \text{and} \quad A_k \equiv Y_T C_k$$

$$C_h \equiv Y_T \lambda cz. E(\mathcal{D}_h z(cz)) \quad \text{and} \quad A_h \equiv Y_T C_h.$$

Note that in  $G(C_k A_k)$  every  $\mathcal{D}_k$  appears in the form  $\dots (\mathcal{D}_k PQ) \dots$ , and that in  $G(C_h A_h)$  every  $\mathcal{D}_h$  appears in the form  $\dots (E(\mathcal{D}_h PQ)) \dots$ . (The proof is a routine exercise.)

Now define a map  $\varepsilon: G(C_k A_k) \rightarrow G(C_h A_h)$  as follows: if  $M \in G(C_k A_k)$ , then  $\varepsilon(M) \equiv$  the result of replacing every subterm  $\mathcal{D}_k PQ \subseteq M$  by  $E(\mathcal{D}_h PQ)$ .

(To be more precise:  $\varepsilon$  is inductively defined by

$$\varepsilon(x) \equiv x, \quad \varepsilon(\mathcal{D}_k) \equiv \mathcal{D}_k, \quad \varepsilon(E) \equiv E$$

$$\varepsilon(\lambda x. A) \equiv \lambda x. \varepsilon(A)$$

$$\varepsilon(\mathcal{D}_k PQ) \equiv E(\mathcal{D}_h \varepsilon(P) \varepsilon(Q))$$

$$\varepsilon(AB) \equiv \varepsilon A(\varepsilon B) \text{ if } AB \text{ is not of the form } \mathcal{D}_h PQ.)$$

Then one easily verifies that  $\epsilon$  is an isomorphism between  $G(C_{k^k}A_k)$  and  $G(C_{h^h}A_h)$  and  $G(C_{h^h}A_h)$  in the sense that

$$1) \epsilon(C_{k^k}A_k) \equiv C_{h^h}A_h$$

2)  $\epsilon$  is a bijection between  $\text{Ter } G(C_{k^k}A_k)$  and  $\text{Ter } G(C_{h^h}A_h)$

3) for all  $M, M' \in G(C_{k^k}A_k)$ :

$$M \xrightarrow{\beta} M' \iff \epsilon(M) \xrightarrow{\beta} \epsilon(M')$$

$$M \xrightarrow{\mathcal{D}_k} M' \iff \epsilon(M) \xrightarrow{\mathcal{D}_h} \epsilon(M').$$

Hence the proof in 1.2.9 that  $G(C_{k^k}A_k) \not\models \text{CR}$  carries over immediately to  $G(C_{h^h}A_h) \not\models \text{CR}$ , via  $\epsilon$ .

*Alternative proof.* Since in  $G(C_{h^h}A_h)$  every  $\mathcal{D}_h$  occurs in a context  $---E(\mathcal{D}_h PQ)---$ , a  $\mathcal{D}_h$ -reduction step in  $G(C_{h^h}A_h)$  must have the form  $---E(\mathcal{D}_h PP)--- \longrightarrow ---EP---$ . This means that  $\mathcal{D}_h$ -reduction in  $G(C_{h^h}A_h)$  can be thought of as the converse of the reduction given by the rule

$$r^* = EP \longrightarrow E(\mathcal{D}_h PP);$$

and  $\lambda \oplus r$  is obviously a regular CRS, hence CR. Therefore (as in Prop. 1.2.7) by Corollary I.6.13 and Proposition I.5.5, we have

$$G(C_{h^h}A_h) \models \text{PP}_{\beta, \mathcal{D}_h}.$$

The remainder of the proof is then entirely similar to that of the previous theorem.

(ii) A similar argument as in (i): let  $C_{sp}, A_{sp}$  be  $C, A$  as defined in 1.2.4 for  $\lambda \oplus \text{SP}$ :

$$C_{sp} \equiv \mathcal{Y}_T \lambda cz. E(\mathcal{D}_0 z) (\mathcal{D}_1 (cz)) \text{ and } A_{sp} \equiv \mathcal{Y}_T C_{sp}.$$

Now  $\zeta: G(C_{k^k}A_k) \longrightarrow G(C_{sp, sp}A_{sp})$ , defined by:  $\zeta(M) \equiv$  result of replacing each subterm  $\mathcal{D}_k PQ \subseteq M$  by

$$E(\mathcal{D}_0 P) (\mathcal{D}_1 Q),$$

is an isomorphism between the two reduction graphs, analogous to the case

in (i). (Note that in  $G(C_{sp} A_{sp})$  no  $\mathcal{D}_0, \mathcal{D}_1$ -steps are possible, only  $\beta, \mathcal{D}$ -steps.)

Hence the result follows as in (i).

*Alternative proof.* Analogous to the alternative proof above, we have

$$G(C_{sp} A_{sp}) \models PP_{\beta, \mathcal{D}}$$

since  $\mathcal{D}$ -reduction in  $G(C_{sp} A_{sp})$  is in fact the converse of  $r^*$ -reduction, where

$$r^* = EP \longrightarrow E(\mathcal{D}(\mathcal{D}_0 P) (\mathcal{D}_1 P)).$$

The remainder of the proof is then again similar to the preceding cases.

1.2.11. We will now prove that there are similar CR-counterexamples for some other non-left-linear CRS's, namely:

- (i) For the TRS's  $\Sigma_k, \Sigma_s$  as in 1.2.1 and 1.2.2. The proofs that the terms CA as defined there yield indeed CR-counterexamples, are merely simplified versions of the ones for  $\lambda \oplus \mathcal{D}_s, \mathcal{D}_k$ .
- (ii) Likewise for the TRS's  $\Sigma_h$  and  $\Sigma_{sp}$  corresponding in the same manner to  $\lambda \oplus \mathcal{D}_h$  and  $\lambda \oplus SP$ .
- (iii) For  $CL \oplus \mathcal{D}_s, \mathcal{D}_k$  there are CR-counterexamples similar to the ones above, bearing in mind that CL allows the analogous fixed point constructions (see I.2) and that the same necessary theorems (Standardization,  $PP_{CL, \mathcal{D}}$ ) hold.
- (iv) For  $CL \oplus \mathcal{D}_h, SP$  there are also similar counterexamples; but in the proof that they are indeed so, there is a technical obstacle. We will deal with these  $\neg$ CR-proofs below.
- (v) For several other non-left-linear extensions of  $\lambda$  and CL there are analogous CR-counterexamples. We will give three examples:

(1)  $\lambda \oplus \mathcal{D}_3$  where the constant  $\mathcal{D}_3$  has the reduction rule  $\mathcal{D}_3 ZZZ \longrightarrow Z$ . Now  $\mathcal{D}_h$  can be defined in  $\lambda \oplus \mathcal{D}_3$  as  $\lambda xy. \mathcal{D}_3 xyy$ , and a CR-counterexample for  $\lambda \oplus \mathcal{D}_3$  is easily found by rewriting the one for  $\lambda \oplus \mathcal{D}_h$ . (Instead of  $\mathcal{D}_h xy$  take  $\mathcal{D}_3 xxy$ .)

(2) Let  $\Sigma$  be the TRS with constants 0, +, - and rules  $0 + Z \rightarrow Z$

$$(Z_1 + Z_2) + Z_3 \longrightarrow Z_1 + (Z_2 + Z_3)$$

$$(-Z) + Z \longrightarrow 0$$

(Instead of  $+ AB$  we have used the infix-notation  $A + B$ .) Then  $\lambda \oplus \Sigma \not\vdash$  CR. For, the counterexample for  $\lambda \oplus \mathcal{D}_S$  can be rewritten: take  $E \equiv 0$  and  $\mathcal{D}_S xy := (-x) + y$ . (Note, however, that  $\Sigma \vdash$  CR by Newman's Lemma.)

(3) Let  $\Sigma = \lambda \oplus$  if  $x$  then  $y$  else  $z$  be  $\lambda$  plus a branching operation defined

by:

$$\begin{aligned} \text{if } \top \text{ then } z_1 \text{ else } z_2 &\longrightarrow z_1 \\ \text{if } \perp \text{ then } z_1 \text{ else } z_2 &\longrightarrow z_2 \\ \text{if } z_0 \text{ then } z_1 \text{ else } z_1 &\longrightarrow z_1 \end{aligned}$$

Then  $\Sigma \not\vdash$  CR. For, writing  $B(x,y,z)$  instead of if  $x$  then  $y$  else  $z$ , we can define  $\mathcal{D}_h$  as follows:  $\mathcal{D}_h := \lambda ab.B(I,a,b)$ .

(It should be noted here that it does not matter whether one extends  $\lambda$  by  $B(x,y,z)$  or by  $B$ , the difference being that  $B(x,y,z)$  has always three arguments, while  $B$  can occur 'alone', as e.g. in  $(\lambda x.x)B$ .)

For CL however, there is a crucial difference:  $CL \oplus B \not\vdash$  CR, analogous to  $CL \oplus \mathcal{D}_h \not\vdash$  CR (see below), but  $CL \oplus B(x,y,z) \vdash$  CR! This will be proved at the end of this chapter.)

(vi) For  $\lambda \eta \oplus \mathcal{D}_h, \mathcal{D}_s, \mathcal{D}_k$ , SP the CR-counterexamples are the same as for  $\lambda$ . The proof that they 'work' requires several technicalities however; see 1.3 below.

1.2.12. THEOREM.  $CL \oplus \mathcal{D}_h \not\vdash$  CR.

PROOF. Translation (by means of  $\tau'$  as in I.2.5.1) of the CR-counterexample for  $\lambda \oplus \mathcal{D}_h$ , viz.

$$CA \equiv (Y_T \lambda cx.E(Dx(cx))) (Y_T (Y_T \lambda cx.E(Dx(cx)))) ,$$

yields:  $\tau'(CA) \equiv \eta\gamma(\eta\eta(\eta\eta\gamma))$  where  $\eta \equiv \tau'(\lambda ab.b(aab))$  and  $\gamma \equiv \tau'(\lambda cx.E(Dx(cx))) \equiv S(K(S(KE)))(SD)$ .

CLAIM 1. In  $G_{CL, \mathcal{D}}(CA)$  a subterm  $\mathcal{D}PQ$  can only occur in a context

- (i)  $\dots E(\mathcal{D}PQ) \dots$  or
- (ii)  $\dots KEB(\mathcal{D}PQ) \dots$  for some  $B$ .

(If (ii) were not the case, postponement of  $\mathcal{D}$ -steps in  $G_{CL, \mathcal{D}}(CA)$  would follow immediately, by an argument as in Proposition 1.2.7.)

Proof of the claim

In  $G_{CL, \mathcal{D}}^{(CA)}$  the symbol  $\mathcal{D}$  can only occur in the following subterms:

$$M_1 \equiv \gamma \equiv S(K(S(KE))) (SD),$$

$$M_2 \equiv K(S(KE))X(SDX), \text{ for some } X \text{ (the head reduct of } M_1 X),$$

$$M_3 \equiv S(KE) (SDX) \text{ for some } X,$$

$$M_4 \equiv KEY(SDXY) \text{ for some } X, Y \text{ (the head reduct of } M_3 Y),$$

$$M_5 \equiv E(SDXY), \quad M'_5 \equiv KEY(\mathcal{D}Y(XY)),$$

$$M_6 \equiv E(\mathcal{D}Y(XY)).$$

Therefore claim 1 follows.

CLAIM 2. Let  $\Sigma$  be CL extended with constants  $\mathcal{D}, E$  and the reduction rules

$$EZ \longrightarrow E(\mathcal{D}ZZ) \quad ('E\text{-reduction}')$$

$$KEZ_1 Z_2 \longrightarrow KEZ_1 (\mathcal{D}Z_2 Z_2) \quad ('KE\text{-reduction}')$$

(so  $\Sigma$  is ambiguous).

Let '(K)E-reduction' be 'E- or KE-reduction'.

Then (K)E-reduction commutes with CL-reduction (i.e. I-, K-, S-reduction).

Proof of the claim

That (K)E- and CL-reduction commute weakly, is easily checked; the most noteworthy case is:

$$\begin{array}{ccc} KEAB & \xrightarrow{KE} & KEA(\mathcal{D}BB) \\ K \downarrow & & \downarrow K \\ EB & \xrightarrow{E} & E(\mathcal{D}BB) \end{array}$$

The proof that they also commute is not immediately obvious (since (K)E-reduction is duplicating) and requires some argument, e.g. the following.

Let us introduce underlining of redexes in  $\Sigma$ ; only the head symbols of E-, I-, K-, S-redexes may be underlined and of a KE-redex the two head-symbols may be underlined. The rules for underlined  $\Sigma$ -reduction are:

$$\begin{aligned} \underline{I}z &\longrightarrow z, \underline{K}z_1z_2 \longrightarrow z_1, \underline{S}z_1z_2z_3 \longrightarrow z_1z_3(z_2z_3), \\ \underline{E}z &\longrightarrow E(Dzz), \underline{KE}z_1z_2 \longrightarrow KEz_1(Dz_2z_2), \\ \underline{KE}z_1z_2 &\longrightarrow \underline{E}z_2, \underline{KE}z_1z_2 \longrightarrow \underline{KE}z_1(Dz_2z_2). \end{aligned}$$

Now underlined reductions are also weakly commuting; again the most noteworthy case is:

$$\begin{array}{ccc} \underline{KEAB} & \xrightarrow{\underline{KE}} & \underline{KEA(DBB)} \\ \underline{K} \downarrow & & \downarrow \underline{K} \\ \underline{EB} & \xrightarrow{\underline{E}} & E(DBB) \end{array}$$

To prove that  $\underline{\Sigma} \models SN$  (i.e. 'Finite developments' for  $\underline{\Sigma}$ ) we can employ the method of weights as in I.4.

Every constant (say  $K$ ) in a  $\underline{\Sigma}$ -term will have a weight ( $|K|$ ) attached to it; during a  $\underline{\Sigma}$ -reduction the descendants of a constant keep the same weight, with one exception.

Here the concept of descendant is for the  $\underline{CL}$ - and  $\underline{E}$ -reductions the usual one (note that  $\underline{CL} \oplus \underline{E}$ -reduction is a regular TRS, for which we have defined a 'canonical' concept of descendant); for  $\underline{KE}$ -reduction it is defined as follows:

$$\begin{array}{c} \underline{KEAB} \\ \vdots \quad \vdots \quad \vdots \quad \vdots \\ \downarrow \quad \downarrow \quad \downarrow \quad \downarrow \\ \underline{KEA(DBB)} \end{array}$$

If  $M \in \text{Ter}(\underline{\Sigma})$ , a weight assignment for  $M$  is called 'good' iff:

$$|I| = |K| = 1, \quad \text{for all } \underline{I}, \underline{K} \text{ in } M;$$

$$|I| = |K| = |S| = |D| = |E| = 0, \quad \text{for not underlined constants;}$$

in each  $\underline{SABC} \subseteq M$ ,  $|S| > 2|C|$  (where  $|C|$  is the sum of all the weights in  $C$ ); in each  $\underline{EB}$ ,  $|E| > 2|B|$ ; in each  $\underline{KEAB}$  or  $\underline{KEAB} \subseteq M$ ,  $|K| = 1$  and  $|E| > 2|B|$ .

Reduction of  $\underline{\Sigma}$ -terms plus weights is as usual (descendants keep their weight) with the following exception:

$$\underline{K^1 E^a}_{AB} \rightarrow K^0 E^0_A(\mathcal{D}BB)$$

$$\underline{\underline{K^1 E^a}}_{AB} \rightarrow \underline{K^1 E^0}_A(\mathcal{D}BB),$$

i.e. the  $E$  loses its weight.

(Several other definitions work just as well.)

Now it is a matter of simple computations to check that

- (a) the weight of a redex  $>$  the weight of its contractum,
- (b) a 'good' weight assignment remains so during reduction,
- (c) terms lose weight during reduction,
- (d) every  $\Sigma$ -term can be given initially a 'good' weight assignment.

(Cf. the proof of Theorem I.4.1.11.)

Hence  $\Sigma \models \text{SN}$ . Therefore, by the usual arguments,  $\Sigma \models \text{CR}$ , and since  $(K)E$ - and  $CL$ -reduction steps 'propagate' as similar steps, we have proved that  $(K)E$ - and  $CL$ -reduction commute. Hence by Proposition I.5.5 the "converse  $(K)E$ -steps", i.e. the  $\mathcal{D}$ -steps, can be postponed. So we have  $G_{CL, \mathcal{D}}(CA) \models \text{PP}_{CL, \mathcal{D}}$ , and the remainder of the proof that  $CA$  yields a  $CR$ -counterexample is similar to previous cases.  $\square$

1.2.13. REMARK. The proof that  $CL \oplus SP \not\models CR$  is similar and is left to the reader.

1.3. In this subsection we want to extend the above negative  $CR$  results from  $\lambda$  to  $\lambda\eta$  (or  $\lambda\beta\eta$ -calculus; see Chapter IV). We will do this by showing that the term  $CA$ , as in the  $CR$ -counterexamples above, has no  $\eta$ -redexes in its  $\beta\mathcal{D}$ -reduction graph  $G_{\beta\mathcal{D}}(CA)$  (hence  $G_{\beta\mathcal{D}}(CA) = G_{\beta\eta\mathcal{D}}(CA)$  and we are done). To establish this fact requires some technical considerations; as a preparation to the first technical proposition, but also for its own sake, we will describe a method of proving a property  $P$  for all  $\beta$ -reducts of some term  $M$  (i.e.  $G_{\beta}(M) \models P$ , or  $G_{\beta}(M) \models \forall N P(N)$ ). Such a method is desirable, since often  $G_{\beta}(M)$  is very complicated. One method is mentioned already in I.12: there a *cofinal* reduction  $\mathcal{R}$  in  $G_{\beta}(M)$  is used. Instead of proving  $G_{\beta}(M) \models P$ , it suffices to prove  $P$  for the terms of  $\mathcal{R}$ . But this method works only if the property  $\neg P$  is invariant under  $\beta$ -reduction; the typical example is:  $P(N) \iff N$  contains the free variable  $x$ . This 'cofinality method' is not applicable for our purpose below.

We will now describe another (somewhat heuristical) method to prove  $G_{\beta}(M) \models P$ , which is based on the Standardization Theorem.

1.3.1. DEFINITION. (i)  $M$  is in *head-normal form* (h.n.f.), w.r.t.  $\beta$ -reduction, if  $M$  is not of the form  $\overrightarrow{RS}$  for a  $\beta$ -redex  $R$  and some  $\overrightarrow{S} = S_1 \dots S_n$  ( $n \geq 0$ ).  $R$  is called the *head-redex* of  $\overrightarrow{RS}$ .

(ii) *Head-reduction* is the contraction of the head-redex, if present.

Notation:  $M \xrightarrow{h} N$ .

(iii) Let  $N \subseteq M$ .  $N$  is called a *derived subterm* of  $M$ , notation  $M \xrightarrow{\text{der}} N$ , iff  $N$  is a proper subterm of  $M$ , not in h.n.f., which is maximal in that respect. Otherwise said: iff (1)  $N \not\subseteq M$ , (2)  $N$  not in h.n.f., (3)  $N' \not\subseteq N$  &  $N'$  not in h.n.f.  $\Rightarrow N' \equiv M$ . If  $M \xrightarrow{\text{der}} N$ , then  $N$  is said to be obtained by *derivation* of  $M$ .

(iv) Let  $A_1, \dots, A_n$  ( $n \geq 0$ ) be the derived subterms of  $M$ . Then we will write  $M \equiv \mathbb{C}_h[A_1, \dots, A_n]$  where  $\mathbb{C}_h[ \dots, ]$  is a  $n$ -ary context, called the *head-context* of  $M$ .

1.3.2. DEFINITION. The *condensed  $\beta$ -reduction graph* of  $M$ , notation:  $G_\beta^C(M)$ , is the least structure containing  $M$  and closed under head-reduction and derivation.

1.3.3. NOTATION. (i) If  $N \subseteq N' \in G_\rho(M)$ , we write  $N \in G_\rho(M)$ . Here  $\rho = \beta, \beta\eta, \beta\eta\mathcal{D}$ .

(ii) In the remainder of this subsection,  $\mathcal{D}$  will stand for  $\mathcal{D}_h$ .

(iv)  $CA$  is the term as in the CR-counterexample for  $\lambda \oplus \mathcal{D}_h$ , i.e.:

$CA \equiv \tau\gamma(\tau(\tau\gamma))$ , where  $\tau \equiv Y_T \equiv (\lambda ab.b(aab))(\lambda ab.b(aab))$ , and

$\gamma \equiv \lambda cx.E(\mathcal{D}x(cx))$ . Furthermore,  $\tau' \equiv \lambda b.b(\tau b)$ , the head-reduct of  $\tau$ .

1.3.4. PROPOSITION. (i) If  $(\lambda y.P)Q \in G_\beta(CA)$ , then either  $Q$  is a variable  $x$  or  $Q$  is a closed term.

(ii) if  $\mathcal{D}MN \in G_{\beta\mathcal{D}}(CA)$ , then  $M \equiv x$  or  $M$  is a closed term.

PROOF. Define the property  $P$  by:  $P(M) \iff$  every argument  $B$  of a  $\beta$ -redex  $(\lambda x.A)B$  in  $M$  is either a variable  $x$  or a closed subterm. So we wish to prove:  $G_\beta(CA) \models P$ .

CLAIM.  $G_\beta^C(CA) \models P \Rightarrow G_\beta(CA) \models P$ .

If the claim is proved, we are done; for, it is easy to check for the finite  $G_\beta^C(CA)$  (shown on p.215) that  $P$  holds for every term. (Remark: the reverse implication ( $\Leftarrow$ ) can be easily proved.)



Proof of the claim. Suppose there is a reduct  $M$  of  $CA$  such that  $\mathcal{P}(M)$ . We have to show that there is some  $N \in G_\beta^C(CA)$  such that  $\mathcal{P}(N)$ .

Let  $\mathcal{R}$  be a standard reduction from  $CA$  to such an  $M$ ; suppose  $\mathcal{R}$  is of minimal length. Say  $\mathcal{R}$  is  $CA \equiv M_0 \xrightarrow{\quad} M_1 \xrightarrow{\quad} \dots \xrightarrow{\quad} M_n \equiv M$ .  $\mathcal{R}$  starts with a (maybe empty) head-reduction:  $M_0 \xrightarrow{h} \dots \xrightarrow{h} M_k \equiv \mathbb{C}_h[A_1, \dots, A_p]$  for some  $k$ . Here  $\mathbb{C}_h[\dots]$  is the head-context of  $M_k$  and  $A_1, \dots, A_p$  are the derived subterms of  $M_k$ . Note that  $M_0, \dots, M_k, A_1, \dots, A_p$  are by definition elements of  $G_\beta^C(CA)$ . If  $k = n$  we are done, therefore. Otherwise: due to the special nature of  $\mathcal{P}$  and to the minimality of  $\mathcal{R}$ , the remainder of  $\mathcal{R}$  will proceed entirely inside one of the  $A_1, \dots, A_p$ , say  $A_j$ . So  $\mathcal{R}$  will proceed by a (possibly empty) head-reduction of  $A_j$ :  $A_j \xrightarrow{h} \dots \xrightarrow{h} P \equiv \mathbb{C}'_h[B_1, \dots, B_q]$ , for some  $P$  having  $B_1, \dots, B_q$  as derived terms. Here we suppress the context  $\mathbb{C}_h[A_1, \dots, A_{j-1}, \square, A_{j+1}, \dots, A_p]$  of the terms  $A_j, \dots, P$ . Again the remainder of  $\mathcal{R}$  proceeds entirely inside one of the  $B_1, \dots, B_q$ , say  $B_s$ . In this way  $\mathcal{R}$  gives rise to a path  $CA \equiv M_0 \xrightarrow{h} \dots \xrightarrow{h} M_k \xrightarrow{\text{der}} A_j \xrightarrow{h} \dots \xrightarrow{h} P \xrightarrow{\text{der}} B_s \xrightarrow{h} \dots \xrightarrow{h} N$  in  $G_\beta^C(CA)$  to some  $N (\subseteq M_n)$ . By the special nature of the property  $\mathcal{P}$  and in view of the head-contexts which have been removed along this path, it is evident that  $\mathcal{P}(N)$  (after a careful consideration of  $G_\beta^C(CA)$ ).

(ii) From (i) we know that every 'substituted subterm' in  $G_\beta(CA)$  is either a variable  $x$  or a closed term. Hence (ii) follows for  $G_\beta(CA)$ . For  $G_{\beta D}(CA)$  the proposition follows easily now, using Postponement of  $\mathcal{D}$ -steps.  $\square$

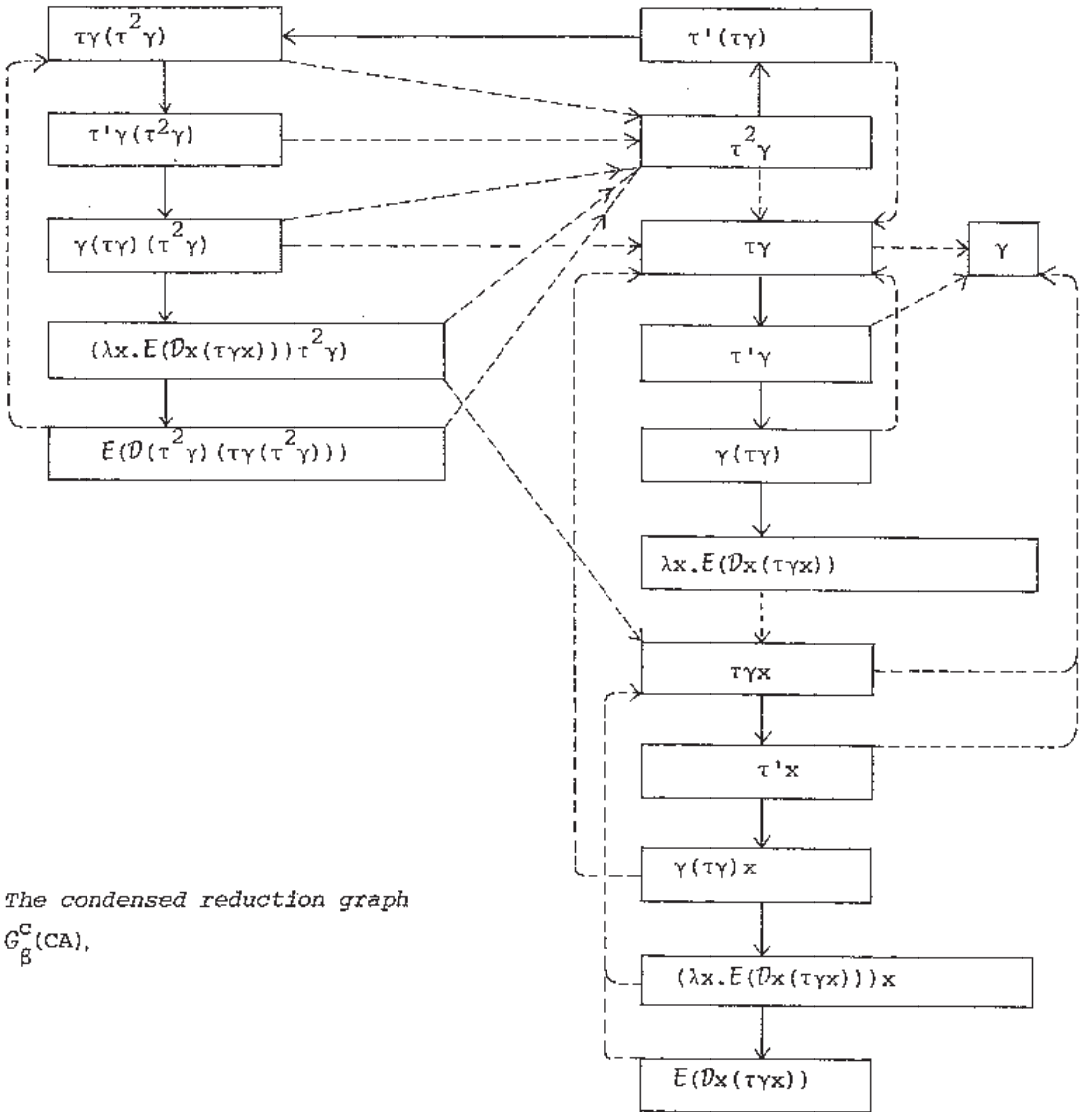

The condensed reduction graph  $G_{\beta}^C(CA)$ .

1.3.5. DEFINITION.  $\lambda I$ (-calculus) is the substructure of  $\lambda$  where in every (sub)term  $\lambda x.A(x)$  the variable  $x$  occurs at least once in  $A(x)$ . Likewise  $\lambda II$  is defined: the  $x$  in  $\lambda x.A(x)$  occurs at least twice in  $A(x)$ .

Obviously,  $Ter(\lambda II)$  is closed under  $\beta$ -reduction.

1.3.6. PROPOSITION.  $D_{xx} \notin G_{\beta D}(CA)$ .

PROOF. Suppose not, and let  $\mathcal{R}$  be a minimal special (see Def.1.2.6)  $\beta\mathcal{D}$ -reduction from CA leading to a subterm  $\mathcal{D}xx$ .

So  $\mathcal{R} = CA \xrightarrow[\beta, \text{ standard}]{\quad} M \xrightarrow[\mathcal{D}]{\quad} N \sqsubseteq \mathcal{D}xx$ .

Now we must have a  $\mathcal{D}xx \sqsubseteq M$ , i.e. by the minimality of  $\mathcal{R}$ ,  $M \rightarrow N$  is the empty reduction. For, a  $\mathcal{D}xx$  can only be created by a  $\mathcal{D}$ -step as follows:

$\mathcal{D}_x(\mathcal{D}xx) \rightarrow \mathcal{D}xx$  or  $\mathcal{D}(\mathcal{D}xx)x \rightarrow \mathcal{D}xx$ . But then we have an 'earlier'  $\mathcal{D}xx$ ; contradiction with the minimality of  $\mathcal{R}$ .

Hence  $\mathcal{D}xx \in G_\beta(CA)$ . However, this cannot be the case, as an inspection of  $G_\beta^C(CA)$  (preceding figure) shows. (Alternative argument:

$\mathcal{D}xx \in G_\beta(CA) \Rightarrow I \equiv \lambda x.x \in G_\beta(CA)$ , otherwise  $\mathcal{D}_x(cx) \sqsubseteq CA$  cannot have  $\mathcal{D}xx$  as descendant. But  $CA \in \lambda II \oplus \mathcal{D}$ , hence  $G_\beta(CA) \sqsubseteq \lambda II \oplus \mathcal{D}$ ; however  $I \notin \lambda II \oplus \mathcal{D}$ .)

□

1.3.7. LEMMA.  $G_{\beta\mathcal{D}}(CA) = G_{\beta\eta\mathcal{D}}(CA)$ .

PROOF. We have to prove that if  $R \equiv \lambda x.Mx$  ( $x \notin FV(M)$ ) is an  $\eta$ -redex, then  $R \notin G_{\beta\mathcal{D}}(CA)$ . Suppose there is such an  $R \in G_{\beta\mathcal{D}}(CA)$ . Note that  $R \notin \lambda II \oplus \mathcal{D}$ . Since  $CA \in \lambda II \oplus \mathcal{D}$  and  $\lambda II \oplus \mathcal{D}$  is closed under  $\beta$ , there must be a  $\mathcal{D}$ -step  $P \xrightarrow[\mathcal{D}]{\quad} Q$  such that  $P \in \lambda II \oplus \mathcal{D}$  and  $Q \notin \lambda II \oplus \mathcal{D}$ . Therefore the  $\mathcal{D}$ -redex contracted in this step, must be of the form  $\mathcal{D}A(x)A(x)$ , where  $x$  has one free occurrence in  $A(x)$ . But then by Proposition 1.3.4.(ii),  $A(x) \equiv x$ . However, this is impossible by Proposition 1.3.6. □

1.3.8. COROLLARY.  $\lambda\eta \oplus \mathcal{D}_h \not\equiv CR$ . □

1.3.9. REMARK. In likewise fashion one can prove that  $\lambda\eta \oplus \mathcal{D}_k, \mathcal{D}_s, S.P. \not\equiv CR$ . The proofs are very much similar to the proof of 1.3.8 and will be left to the reader.

## 2. INTERMEZZO. An intuitive explanation via Böhm trees.

In order to 'explain' the failure of CR for the non-left-linear CRS's which we considered above, it is convenient to use the concept of *Böhm tree* (BT) of a term  $M$ ; notation  $BT(M)$ . This  $BT(M)$  coincides with what is called the value of  $M$  in e.g. BERRY-LÉVY [79]. We will not give a precise definition of  $BT(M)$  here; see BARENDREGT [80] for such a definition (for the case of  $\lambda$ -calculus) or the paper just cited (for RPS's). Let us merely introduce the concept by an example. Consider the regular part of  $\Sigma_s$  as in

1.2.1, i.e. the TRS with the rules  $Cz \rightarrow Dz(Cz)$ ,  $A \rightarrow CA$ . Then one can develop an "expansion" (cf. the decimal expansion of numbers) of say the term  $CA$ , in an attempt to find a normal form, as follows:

$$CA \rightarrow DA(CA) \rightarrow D(CA)(CA) \rightarrow D(DA(CA))(DA(CA)) \rightarrow \dots$$

or, in tree notation, where  $PQ_1 \dots Q_n$  is written as

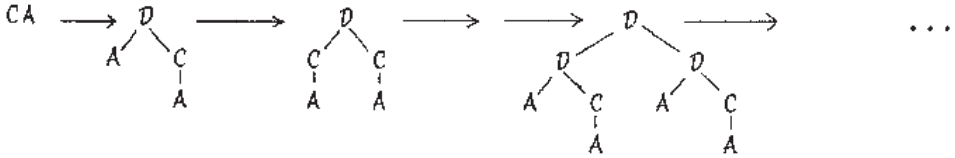
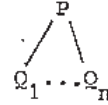

In this way we find, as the 'infinite normal form' of  $CA$ , the tree

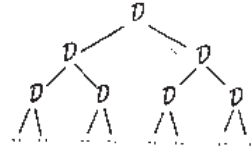
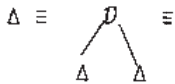

and this is  $BT(CA)$ .

The same expansion is possible in  $\lambda$ -calculus, CL, or other regular CRS's. (Note that we restrict ourselves to regular CRS's in computing BT's; for then we are assured of the unicity of the BT, regardless of the particular computation. In fact, one can prove the CR theorem for infinitary reductions of infinitary terms, i.e. trees, if the reduction rules are combinatory and regular in the sense of Chapter II and this Chapter. The BT's are then the unique normal forms.)

Now consider again  $BT(CA) \equiv \Delta$ . We will now extend the non-left-linear  $D$ -reductions to trees (say for  $\mathcal{D}_s$ ):

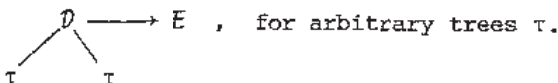

E.g. we have the reductions:

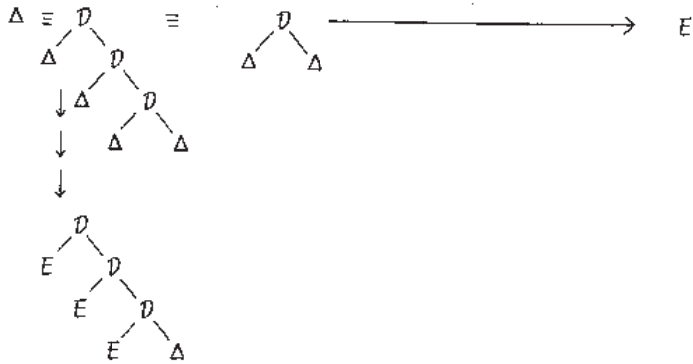

It is still possible now to find a common reduct, namely by "compensating" the "balance-disturbing"  $\mathcal{D}$ -steps in the vertical reduction:

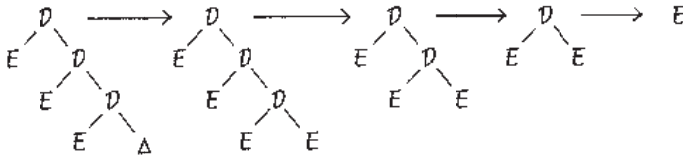

However, if we had executed infinitely many  $\mathcal{D}$ -contractions in the vertical reduction, as in the next figure, we would have lost the possibility of 'compensating':

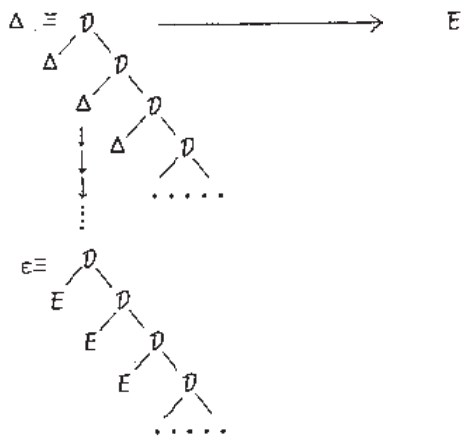

because here the trees  $E$  and  $\epsilon \equiv$   have obviously no common reduct.

Now this is precisely what happens in the CR-counterexamples above:

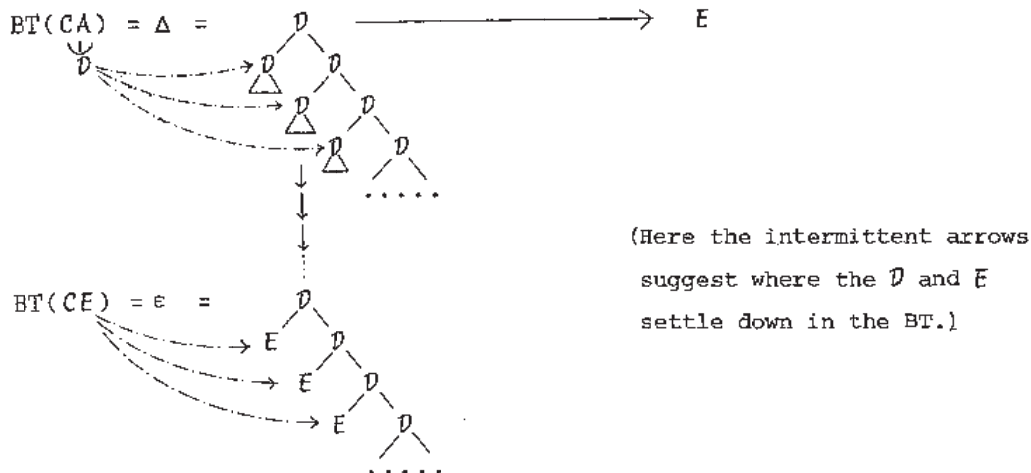

That is, the (finite) reduction  $CA \rightarrow CE$  has had the same effect, in the corresponding BT's, as the infinite vertical sequence of infinitely many  $\mathcal{D}$ -steps.

That it is indeed plausible that  $E \not\rightarrow CE$  follows from the particular state of their BT's in view of the following facts, which we will not prove (since this is only an intuitive explanation):

- (1) the BT of a term is invariant under  $\beta$ -reductions;
- (2) if  $M \xrightarrow{\mathcal{D}} N$  then  $BT(M) \xrightarrow{\omega} BT(N)$ , where  $\xrightarrow{\omega}$  is a possibly infinite sequence of  $\mathcal{D}$ -steps

For  $\mathcal{D}_k$  the BT's corresponding to the terms in the CR-counterexample in 1.2.2, 1.2.3 are:

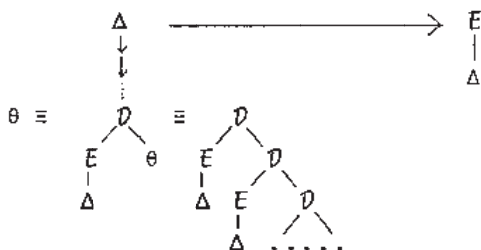

and for  $\mathcal{D}_h$ :

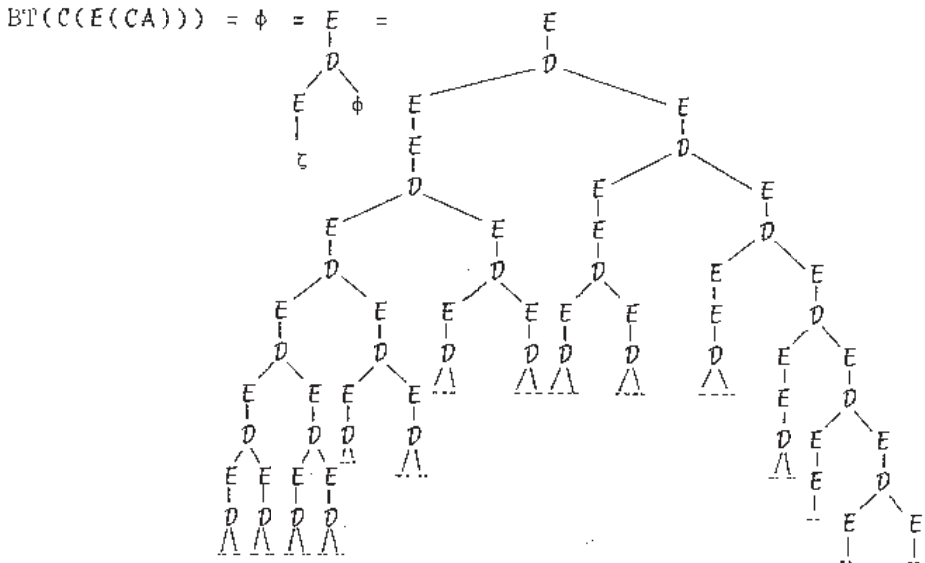
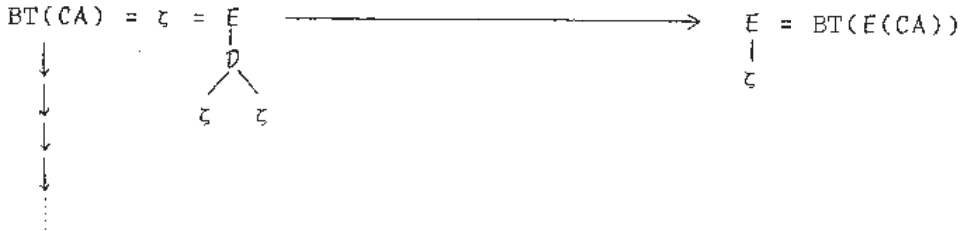

and the same intuitive reasoning applies.

As a final remark to this intuitive intermezzo, let us conclude that the above examples show that also when dealing with infinite "term-trees" and infinite 'combinatory' reductions (of ordinal length) of them, the left-linearity of the reduction rules is a necessary condition for the CR property.

3. ADDITIONAL PROPERTIES OF  $\lambda(CL) \oplus \mathcal{D}_h, \mathcal{D}_s, \mathcal{D}_k, SP$

The CR-property failing for the above discussed CRS's  $\lambda$  (or CL)  $\oplus \mathcal{D}_h, \mathcal{D}_s, \mathcal{D}_k, SP$ , some other questions arise about them: namely whether they are consistent, whether the property UN (Uniqueness of Normal forms, see Def.I.5.6) holds, whether the property NF (Def.I.5.6) holds, and whether these CRS's are conservative extensions of  $\lambda$  (or CL). In the

presence of CR, all these properties would have been corollaries, as remarked in Theorem I.5.11.

In order to answer (most of) these questions, we will need some preparation: a technical lemma and a theorem which is of independent interest. The lemma, which follows now, is a partial CR result. It says that given a term  $A$  and two divergent reductions  $A \twoheadrightarrow C$ ,  $A \twoheadrightarrow B$ , a common reduct can still be found, if one of the two reductions is free of  $\mathcal{D}$ -steps. Note that this is consonant with the above CR-counterexamples, where in both reductions a  $\mathcal{D}$ -step occurred.

3.1. LEMMA. Let  $\Sigma$  be  $\lambda \oplus \mathcal{D}_s, \mathcal{D}_h, \mathcal{D}_k, SP$ . Then  $\beta$ -reductions commute with arbitrary reductions, i.e.:

$\forall A, B, C \exists D$

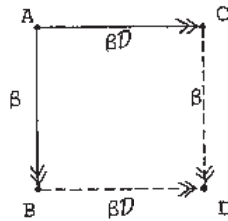

(Here  $\xrightarrow{\beta D}$  is a  $\beta$ -step or  $\mathcal{D}$ -step.)

Similar in case  $\Sigma = \Sigma' \oplus \mathcal{D}_s, \mathcal{D}_h, \mathcal{D}_k, SP$ , where  $\Sigma'$  is a regular TRS.

PROOF. A simple argument shows that the statement in the lemma is equivalent to the case where the reduction  $A \twoheadrightarrow C$  consists of one  $\mathcal{D}$ -step:

$\forall A, B, C \exists D$

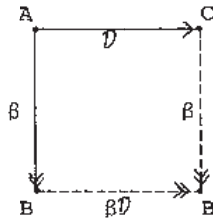

and similarly for  $\Sigma'$ . Let us first deal with the simpler case of  $\Sigma'$ ; say  $\Sigma' = CL$ . So suppose that  $A \xrightarrow{\mathcal{D}} C$  and  $A \xrightarrow{CL} B$ ; say  $A \equiv \mathbb{C}[DPP]$  where  $DPP$  is the  $\mathcal{D}$ -redex contracted in the step  $A \xrightarrow{\mathcal{D}} C$ . (The case of  $SP$  is similar.) So  $C \equiv \mathbb{C}[E]$ , resp.  $\mathbb{C}[EP]$ , resp.  $\mathbb{C}[P]$  depending on which CRS we are considering; say this is  $CL \oplus \mathcal{D}_h$ , then  $C \equiv \mathbb{C}[P]$ . (The other cases are similar.)

Now underline in  $\mathcal{R}$ :  $A \xrightarrow{CL} B$  the redex  $DPP$  in  $A$  and all its



descendants in  $\mathcal{R}$ . So  $B$  contains underlined subterms  $\underline{DQ_1R_1}, \dots, \underline{DQ_\ell R_\ell}$  for some  $\ell \geq 0$  ("unbalanced" descendants of the "balanced"  $\mathcal{D}$ -redex  $\underline{DPP}$ ). Obviously all these underlined subterms are disjoint, since  $\mathcal{R}$  is a CL-reduction.

$\mathcal{R}$  can be separated into an "internal" part and an "external" part w.r.t. the underlined subterms, by calling a step in  $\mathcal{R}$  internal if it takes place inside an underlined  $\underline{DQR}$ , external otherwise. Let  $\mathcal{R}_{\text{ext}}$  be the reduction obtained from  $\mathcal{R}$  by replacing every  $\underline{DQR}$  in it by some variable  $x$ . Let  $\mathcal{R}_{\text{ext}}^*: C \longrightarrow \dots \longrightarrow D'$  be  $\mathcal{R}_{\text{ext}}$  where  $x$  is everywhere replaced by  $P$ . So now we have

$$B \equiv \text{--- } \underline{DQ_1R_1} \text{--- } \dots \text{--- } \underline{DQ_\ell R_\ell} \text{---}$$

and

$$D' \equiv \text{--- } P \text{--- } \dots \text{--- } P \text{---}$$

Furthermore, we note that the internal reduction part of  $\mathcal{R}$  consists of "unbalancing" reductions  $P \xrightarrow{\text{CL}} Q_i$  and  $P \xrightarrow{\text{CL}} R_i$  for  $i = 1, \dots, \ell$ . So by CR for CL, we can find common CL-reducts  $Q_i \xrightarrow{\text{CL}} S_i \longleftarrow R_i$  ( $i = 1, \dots, \ell$ ). Now let

$$B' \equiv \text{--- } \underline{DS_1S_1} \text{--- } \dots \text{--- } \underline{DS_\ell S_\ell} \text{---}$$

and

$$D \equiv \text{--- } S_1 \text{--- } \dots \text{--- } S_\ell \text{---},$$

then we have

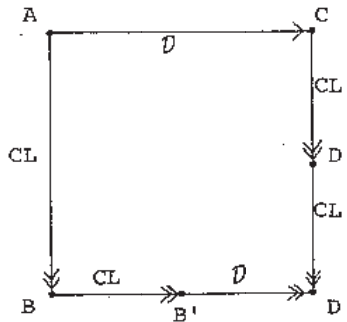

Likewise for  $CL \oplus \mathcal{D}_s, \mathcal{D}_k$ . Note that we proved more than necessary: instead of  $B \xrightarrow{CL, \mathcal{D}} D$  even  $B \xrightarrow{CL} B' \xrightarrow{\mathcal{D}} D$ . (This is only non-trivial for  $CL \oplus \mathcal{D}_h$  since there  $PP_{CL, \mathcal{D}}$  does not hold.)

For  $\lambda$ -calculus instead of CL, the proof is complicated by the fact that B may contain nested underlining (i.e. the descendants of  $\mathcal{D}PP \subseteq A$  may be substituted in each other). The complications can be circumvented, however, by means of Lemma I.4.3.7, which says that in a  $\beta$ -development no such nestings can occur. So if  $A \xrightarrow{\beta} B$  is a development, the  $\mathcal{D}Q_i R_i$  ( $i = 1, \dots, \ell$ ) are disjoint; and then the above proof for CL carries over without change. I.e., we have

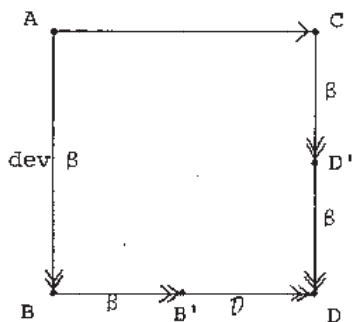

Furthermore, it is not hard to see that here  $B \xrightarrow{\beta} B'$  and  $C \xrightarrow{\beta} D$  are again developments. Using this, it is routine to prove that a  $\mathcal{D}$ -step can be "pushed through" an arbitrary  $\beta$ -reduction, being a sequence of  $\beta$ -developments, as suggested by the following figure:

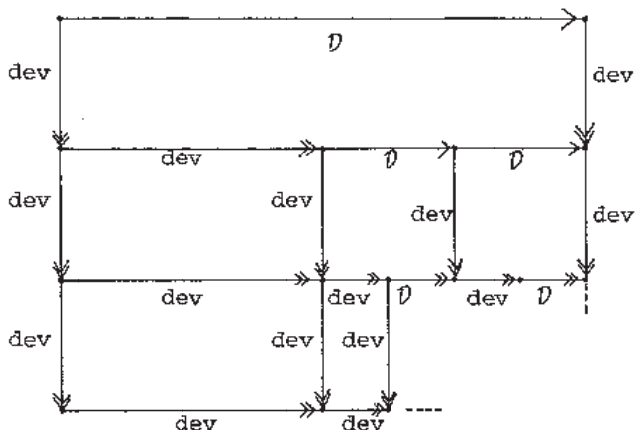

The closure of this diagram is ensured by the fact that the "dev-steps" do not split, in their propagation to the right.  $\square$

The next theorem is a slight generalization of Theorem 1.4 in MITSCHKE [77].

3.2. DEFINITION. Let  $\Sigma$  be some reduction system, and let  $P$  be an  $n$ -ary predicate on  $\text{Ter}(\Sigma)$ . Then

- (i)  $P$  is closed under ( $\Sigma$ -) reduction if: whenever  $A_i \rightarrow A'_i$  ( $i = 1, \dots, n$ ), then  $P(A_1, \dots, A_n) \Rightarrow P(A'_1, \dots, A'_n)$ .
- (ii)  $P$  is closed under substitution if:

$$P(A_1, \dots, A_n) \Rightarrow P(A_1^\sigma, \dots, A_n^\sigma)$$

where  $A_i^\sigma$  denotes  $[x := B] A_i$ , the result of some substitution into  $A_i$ .

3.3. THEOREM (G. Mitschke) ('Reduction by cases', first version).

Let  $\lambda\mathcal{D}$  (or  $\text{CL}\mathcal{D}$ ) be the reduction system obtained by adding to  $\lambda(\text{CL})$  a constant  $\mathcal{D}$  and rules (for  $n, k \geq 1$ ):

$$\begin{array}{lll} \mathcal{D}A_1 \dots A_n \longrightarrow M_1 & \text{if} & P_1(A_1, \dots, A_n) \\ \vdots & \vdots & \vdots \\ \mathcal{D}A_1 \dots A_n \longrightarrow M_k & \text{if} & P_k(A_1, \dots, A_n) \end{array}$$

where the  $M_i$  are closed  $\lambda\mathcal{D}$  (or  $\text{CL}\mathcal{D}$ )-terms and the  $P_i$  ( $i = 1, \dots, k$ ) are  $n$ -ary predicates on  $\text{Ter}(\lambda\mathcal{D})$  (resp.  $\text{Ter}(\text{CL}\mathcal{D})$ ) satisfying:

- (i) the  $P_i$  are pairwise disjoint,
- (ii) the  $P_i$  are closed under reduction (including  $\mathcal{D}$ -reduction)
- (iii) the  $P_i$  are closed under substitution (in case of  $\lambda\mathcal{D}$ ).

Then  $\lambda\mathcal{D}(\text{CL}\mathcal{D}) \models \text{CR}$ .

PROOF. As in MITSCHKE [77], we can prove by inspection of cases that

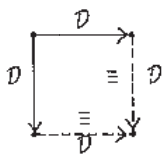

(1)

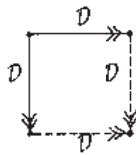

(2)

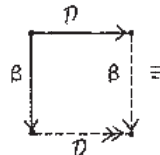

(3)

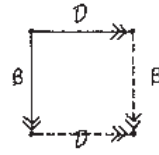

(4)

(Here  $\xrightarrow{\equiv}$  is 0 or 1 step; i.e. the reflexive closure of  $\rightarrow$ .) So  $\mathcal{D}$ -,  $\beta$ -reductions are self-commuting and commute with each other (see Def.I.5.2); hence by the Lemma of Hindley-Rosen (I.5.7.(4)) CR follows for  $\lambda\mathcal{D}$ . Likewise for  $CL\mathcal{D}$ .  $\square$

3.3.1. REMARK. (i) In the formulation of MITSCHKE [77],  $n = k = 2$  and the conditions on  $P_i$  are more restrictive (the  $A_i$  have to be closed).

(ii) For some applications of the theorem, see MITSCHKE [77]. One of them is:

$$\lambda \otimes \mathcal{D}AB \longrightarrow \begin{cases} K \text{ if } A, B \text{ are closed normal} \\ \text{forms and } A \equiv B \\ KI \text{ " " and } A \not\equiv B \end{cases}$$

is CR. This is 'Church's  $\delta$ -reduction', see also 1.15.(4).

(iii) Also 'Church's generalized  $\delta$ -rules' (as in 1.17) fall under the scope of this theorem.

We will now give a strengthening of Mitschke's theorem, both for use in the sequel and for its own interest.

3.4. THEOREM. ('Reduction by cases', second version.)

Let  $\lambda\mathcal{D}$  (or  $CL\mathcal{D}$ ) be as in the previous theorem, where  $M_i$  is replaced by  $M_i(A_1, \dots, A_n)$ ; i.e. the  $M_i$  may contain the metavariables  $\vec{A}$  now.

Then  $\lambda\mathcal{D}(CL\mathcal{D}) \models CR^+$  (the CR property in the strong version as e.g. in Theorem I.6.9).

PROOF. The proof of 3.3 does not carry over to the present case, since the assertions expressed in the diagrams (1), (3) there are no longer true ((2) and (4) stay true, as we will see), since now also  $\mathcal{D}$ -reductions may have multiplicative effect.  $\lambda\mathcal{D}(CL\mathcal{D})$  is not a CRS, but resembles one in the following sense. Let  $\lambda\vec{\mathcal{D}}$  (and likewise  $CL\vec{\mathcal{D}}$ ; we will refer only to  $\lambda$  in the remainder of this proof) be  $\lambda$ -calculus augmented by constants  $\mathcal{D}, \mathcal{D}_1, \dots, \mathcal{D}_k$  and rules

$$\begin{array}{l} \mathcal{D}_1 A_1 \dots A_n \longrightarrow M_1(A_1, \dots, A_n) \\ \vdots \\ \mathcal{D}_k A_1 \dots A_n \longrightarrow M_k(A_1, \dots, A_n). \end{array}$$

$\mathcal{D}$  is now an inert constant. Then, obviously,  $\lambda\vec{\mathcal{D}}$  is a regular CRS and even a definable extension of  $\lambda$ -calculus. Hence  $\lambda\vec{\mathcal{D}} \models \text{FD}, \text{CR}^+$  as we proved in Chapter I (Theorems I.4.1.11 and I.6.9) using the method of developments, decreasing weights, and reduction diagrams.

Now, in order to make the resemblance between  $\lambda\mathcal{D}$  and  $\lambda\vec{\mathcal{D}}$  closer, let us attach a subscript  $i$  to  $\mathcal{D}$  in each subterm  $\mathcal{D}A_1 \dots A_n$  where  $P(A_1, \dots, A_n)$ . Note that these subscripts are 'persistent' during a reduction, due to the requirements (i), (ii), (iii) in the theorem. (The resemblance is not complete since in  $\lambda\mathcal{D}$  we may have e.g.

$$(\lambda x. \dots x\vec{A} \dots x\vec{B} \dots)\mathcal{D} \longrightarrow \dots \mathcal{D}_1 \vec{A} \dots \mathcal{D}_2 \vec{B} \dots \text{ if } P_1(\vec{A}) \text{ and } P_2(\vec{B}) \text{ hold.}$$

Now the point is that all the definitions (elementary diagram, underlining, development, weights) and theorems there-about used in proving  $\lambda\vec{\mathcal{D}} \models \text{FD}, \text{CR}^+$ , carry over without effort to  $\lambda\mathcal{D}$ . For, a development in  $\lambda\mathcal{D}$  is in fact nothing else than a development in  $\lambda\vec{\mathcal{D}}$ . To be more precise: let  $M \in \text{Ter}(\lambda\mathcal{D})$  and underline some  $\beta$ -redexes and " $\mathcal{D}_i$ "-redexes. Let  $\mathcal{R}$  be some development of these underlined redexes. Then  $\mathcal{R}$  is also a development of  $M \in \text{Ter}(\lambda\vec{\mathcal{D}})$ , but for one thing: in  $\mathcal{R}$  a  $\mathcal{D}$  may become a  $\mathcal{D}_i$  (see the example above) which is of course not possible in the regular CRS  $\lambda\vec{\mathcal{D}}$ . In completing a diagram  $\mathcal{D}$  these subscripts, which appear out of the blue, do not bother us however; ignoring them the whole diagram construction can be thought of as taking place in  $\lambda\vec{\mathcal{D}}$ , so it terminates indeed. So now we have  $\text{CR}^+$  for  $\lambda\mathcal{D}$ -developments; to obtain  $\text{CR}^+$  for arbitrary reductions is then a small step.  $\square$

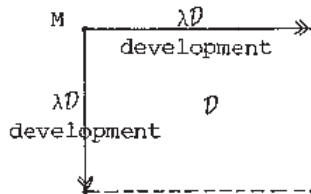

3.4.1. REMARK. (i) Note that the predicate  $P(A, B) \iff A \equiv B$  is not closed under reduction. Otherwise the previous theorem would yield that

$\lambda \oplus (\mathcal{D}AB \longrightarrow A \text{ if } A \equiv B)$ , i.e.  $\lambda \oplus \mathcal{D}_h$ , was CR.

(ii) An example:  $\Sigma = \lambda \oplus \begin{cases} \mathcal{D}IA \longrightarrow A \\ \mathcal{D}KA \longrightarrow AA \end{cases}$  is CR, by the previous theorem

where  $P_1(A_1, A_2) \iff A_1 \equiv I$  and  $P_2(A_1, A_2) \iff A_1 \equiv K$  clearly satisfy the three requirements. However,  $\Sigma$  is also a regular CRS, so this application is only

illustrative and not essential.

(iii) The same as in (ii) can be said for Aczel's 'Definition by cases', as in Example 1.15.(3).

(iv) An inspection of the proof shows that instead of  $\lambda$ , CL any definable extension of  $\lambda$ -calculus (or substructure thereof) can be taken. We expect moreover that the theorem holds for an arbitrary regular CRS  $\Sigma$  instead of  $\lambda$ , CL, but did not work out the details. (For regular TRS's  $\Sigma$  it is easy.)

We will now answer several of the questions posed at the beginning of this section, in the following table, and give the proofs afterwards. (We will only mention  $\lambda$ , but everything holds for CL as well.)

	CR	consistency	conservativity	UN	NF
$\lambda \oplus \text{SP}$	-	+	+	?	-
$\lambda \oplus \mathcal{D}_h \text{ZZ} \longrightarrow Z$	-	+	+	+	-
$\lambda \oplus \mathcal{D}_s \text{ZZ} \longrightarrow E$	-	+	+	+	-
$\lambda \oplus \mathcal{D}_k \text{ZZ} \longrightarrow EZ$	-	+	+	+	+

3.5. Conservativity and consistency. The consistency of the CRS's is an immediate corollary of the conservativity of these extensions over  $\lambda$ ; see I.5.10.

To establish the conservativity of  $\lambda \oplus \text{SP}$  is a difficult matter; this is done in DE VRIJER [80]. The consistency alone can also be proved by elegant model theoretic means as in DE VRIJER [80], using the Graph Model  $\mathcal{P}\omega$ ; or in SCOTT [77], using an even faster construction.

For the remaining three CRS's the conservativity over  $\lambda$  is easily established:

3.5.1. THEOREM.  $\lambda \oplus \mathcal{D}_s, \mathcal{D}_k, \mathcal{D}_h$  are conservative over  $\lambda$ .

PROOF. Let  $\mathcal{D}$  be  $\mathcal{D}_s, \mathcal{D}_k, \mathcal{D}_h$ , and now consider next to  $\lambda \oplus \mathcal{D}$ , the CRS  $\lambda \oplus \mathcal{D}^*$ , where  $\mathcal{D}^*$  is a new constant with the reduction rule

$$\mathcal{D}_s^* z_1 z_2 \longrightarrow E, \text{ resp. } \mathcal{D}_k^* z_1 z_2 \longrightarrow E z_1, \text{ resp. } \mathcal{D}_h^* z_1 z_2 \longrightarrow z_1.$$

So  $\lambda \oplus \mathcal{D}^*$  is a regular CRS, hence CR, and hence (see I.5.11) conservative over  $\lambda$ . That is, given a conversion  $\Gamma^*$  in  $\lambda \oplus \mathcal{D}^*$  between  $\lambda$ -terms  $A, B$ , we can find a common  $\beta$ -reduct  $C$ :

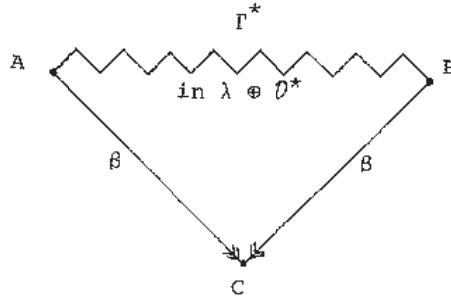

Now if  $\Gamma$  is a conversion between  $A, B \in \text{Ter}(\lambda)$  in  $\lambda \oplus \mathcal{D}$ , then after replacing each  $\mathcal{D}$  by  $\mathcal{D}^*$  we have a conversion  $\Gamma^*$  as above in  $\lambda \oplus \mathcal{D}^*$ . Hence the result follows.  $\square$

3.5.1.1. REMARK. The replacement of  $\mathcal{D}$  by  $\mathcal{D}^*$ , i.e. dropping the non-left-linearity of the  $\mathcal{D}$ -rule, yields a regular CRS in the proof above. Such an attempt to "regularization" fails however for  $\lambda \oplus \text{SP} = \lambda \oplus (\mathcal{D}, \mathcal{D}_0, \mathcal{D}_1)$ ; for consider  $\lambda \oplus (\mathcal{D}^*, \mathcal{D}_0, \mathcal{D}_1)$  and rules

$$\mathcal{D}_1(\mathcal{D}^* z_0 z_1) \longrightarrow z_i \quad (i = 0, 1)$$

$$\mathcal{D}^*(\mathcal{D}_0 z_0)(\mathcal{D}_1 z_1) \longrightarrow z_0.$$

Then the rules are left-linear indeed, but they remain ambiguous. Moreover they are inconsistent:

$$x = \mathcal{D}_1(\mathcal{D}^* Ax) = \mathcal{D}_1(\mathcal{D}^*(\mathcal{D}_0(\mathcal{D}^* Ax))(\mathcal{D}_1(\mathcal{D}^* By))) = \mathcal{D}_1(\mathcal{D}^* By) = y.$$

This may illustrate the difficulty of the syntactical treatment of  $\lambda \oplus \text{SP}$ .

3.6. The Normal Form property (NF). The failure of CR for  $\lambda \oplus \text{SP}, \mathcal{D}_h, \mathcal{D}_s, \mathcal{D}_k$  entails also the failure of NF (see Def.I.5.6) for the first three CRS's, as we shall show; surprisingly, for  $\lambda \oplus \mathcal{D}_k$  we do have NF.

3.6.1. THEOREM.  $\lambda \oplus \mathcal{D}_s, \mathcal{D}_h, \text{SP} \not\models \text{NF}$ .

PROOF. For  $\mathcal{D}_h$ . Let  $\square, \square', \square''$  be the terms  $CA, E(CA), C(E(CA))$  as in the CR-counterexample in 1.2.4. So  $\square \twoheadrightarrow \square', \square''$  and  $\square' \not\downarrow \square''$ . Let

$\langle M \rangle := \lambda z.zM$  and  $KM := \lambda z.M (z \downarrow_{\text{FV}(M)})$ . (For CL,  $\langle M \rangle := SI\{KM\}$  as is seen using I.2.5.1.) Now consider the reductions:

$$\begin{array}{c} \mathcal{D}_h \langle \square \rangle \langle \square \rangle (KI) \longrightarrow \langle \square \rangle (KI) \longrightarrow KIO \longrightarrow I. \\ \downarrow \\ \mathcal{D}_h \langle \square' \rangle \langle \square'' \rangle (KI). \end{array}$$

Here the last term cannot reduce to the normal form  $I \equiv \lambda x.x$  since  $\square' \not\downarrow \square''$ . Hence NF fails.

For  $\mathcal{D}_s$ . Let  $\square, \square', \square''$  be as in the CR-counterexample for  $\lambda \oplus \mathcal{D}_s$  in 1.2.3. Consider:

$$\begin{array}{c} \mathcal{D}_s \square \square \longrightarrow E, \text{ a normal form} \\ \downarrow \\ \mathcal{D}_s \square' \square'' \text{ and now } \mathcal{D}_s \square' \square'' \not\rightarrow E \text{ since } \square' \not\downarrow \square''. \end{array}$$

For SP. Analogous to the case of  $\mathcal{D}_h$ :

$$\begin{array}{c} \mathcal{D}(\mathcal{D}_0 \langle \square \rangle) (\mathcal{D}_1 \langle \square \rangle) (KI) \longrightarrow I \\ \downarrow \quad \nearrow \\ \mathcal{D}(\mathcal{D}_0 \langle \square' \rangle) (\mathcal{D}_1 \langle \square'' \rangle) (KI) \end{array}$$

□

3.6.2. THEOREM.  $\lambda \oplus \mathcal{D}_k \not\models \text{NF}$ .

PROOF. Let  $N$  be a normal form in  $\lambda \oplus \mathcal{D}_k$  and suppose  $M$  is convertible to  $N$ . So suppose there is a conversion  $N \equiv N_0 \longrightarrow N_1 \longrightarrow \dots \longrightarrow N_m \equiv M$  where each  $\longrightarrow$  is  $\longrightarrow$  or  $\longleftarrow$ . We have to prove  $M \twoheadrightarrow N$ . Suppose  $M \not\rightarrow N$ , and let  $N_{k+1}$  be the first term in the conversion such that  $N_{k+1} \not\rightarrow N$ . Then we have the situation



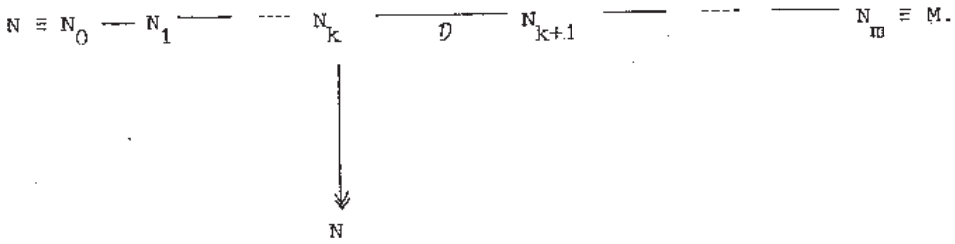

For, the step  $N_k \xrightarrow{\quad} N_{k+1}$  in the conversion cannot be  $N_k \xleftarrow{\quad} N_{k+1}$  since then also  $N_{k+1} \twoheadrightarrow N$ , contrary to the assumption; so  $N_k \xrightarrow{\quad} N_{k+1}$ . Moreover, this cannot be a  $\beta$ -step by Lemma 3.1.

Applying Postponement of  $\mathcal{D}$ -steps in  $N_k \twoheadrightarrow N$  (Prop.1.2.7) and again Lemma 3.1, we have:

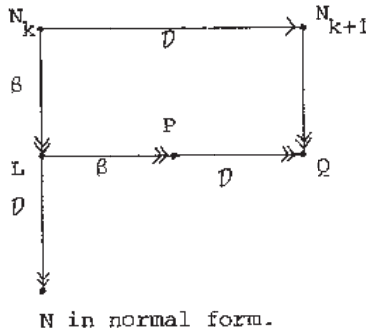

Now, since  $N$  is a normal form and  $L \twoheadrightarrow N$  consists of  $\mathcal{D}_k$ -steps, it is easy to see that  $L$  cannot contain  $\beta$ -redexes. (Note that for  $\mathcal{D}_s$  the proof would break down at this point; for  $\mathcal{D}_h$  even earlier, since then  $PP_{\beta\mathcal{D}}$  fails.)

Hence  $L \equiv P$ . Since  $\mathcal{D}$ -reductions alone are CR (by Newman's Lemma I.5.7.(1):  $\mathcal{D}$ -reductions have the WCR-property and SN is obvious), we have therefore:

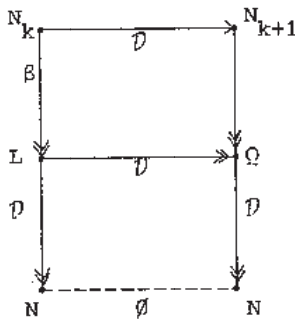

(the bottom  $\mathcal{D}$ -reduction being  $\emptyset$  because  $N$  is a normal form)

But this contradicts our assumption  $N_{k+1} \not\rightarrow N$ . Hence  $N_m = M \rightarrow N$ , i.e. NF holds.  $\square$

3.7. The Unicity of Normal forms (UN, see Def.I.5.6).

That  $\lambda \oplus \mathcal{D}_k \models \text{UN}$  follows immediately by the previous theorem and the following general fact, whose proof is trivial:

3.7.1. PROPOSITION. For all ARS's:  $\text{NF} \Rightarrow \text{UN}$ .  $\square$

For the CRS's  $\lambda \oplus \mathcal{D}_s, \mathcal{D}_h$  the property UN turns out to hold also, but the proof is more complicated. For  $\lambda \oplus \text{SP}$  the question is open; we conjecture that  $\lambda \oplus \text{SP} \models \text{UN}$ .

3.7.2. THEOREM.  $\lambda \oplus \mathcal{D}_s, \mathcal{D}_h \models \text{UN}$ .

PROOF. The proof is based on an idea of R. de Vrijer and an application of Theorem 3.4.

Let  $\Sigma$  be  $\lambda \oplus \mathcal{D}_h \text{ZZ} \rightarrow Z$ . (The proof for  $\mathcal{D}_s$  is similar to the one for  $\mathcal{D}_h$ . For  $\mathcal{D}_k$  the proof works also, by the way.) Let  $\Sigma^*$  be  $\lambda \oplus$  a constant  $\mathcal{D}^*$  and the rule

$$\mathcal{D}^* AB \rightarrow A \quad \text{iff} \quad \phi(A) =_{\Sigma} \phi(B)$$

where  $\phi: \text{Ter}(\lambda \oplus \mathcal{D}^*) \rightarrow \text{Ter}(\lambda \oplus \mathcal{D})$  is the operation of erasing every  $*$ , and  $=_{\Sigma}$  denotes convertibility in  $\Sigma$ . (E.g.

$$\mathcal{D}^* (\mathcal{D}^* II) I \rightarrow \mathcal{D}^* II \quad \text{since} \quad \mathcal{D} II =_{\Sigma} I$$

but not

$$\mathcal{D}^* IK \rightarrow I \quad \text{since} \quad I \neq_{\Sigma} K.)$$

To simplify notation, we will suppress  $\phi$  from now on.

We claim that the predicate  $P(A, B) : \Leftrightarrow A =_{\Sigma} B$  is closed under  $\Sigma^*$ -reduction and under substitution. The closure under substitution is trivial. To check the closure under reduction: let

$$A, B \in \text{Ter}(\lambda \oplus \mathcal{D}^*), \quad A =_{\Sigma} B \quad \text{and} \quad A \xrightarrow{\Sigma^*} A'$$

So to prove is  $A' =_{\Sigma} B$ . The only noteworthy case is that  $A \rightarrow A'$  is a  $\mathcal{D}^*$ -step:  $A \equiv \mathcal{C}[\mathcal{D}^*PQ] \xrightarrow{\mathcal{D}^*} \mathcal{C}[P] \equiv A'$ , where it is given that  $P =_{\Sigma} Q$ . (\*)  
 So we have

$$A' \equiv \mathcal{C}[P] \xleftarrow{\mathcal{D}^*} A \equiv \mathcal{C}[\mathcal{D}^*PQ] \overset{\text{conversion in } \Sigma}{\text{AAAAAAAAAAAAAAAAAAAAAAAA}} B$$

and using (\*) we can obtain from this:

$$A' \equiv \mathcal{C}[P] \xleftarrow{\Sigma} \mathcal{C}[DPQ] \overset{\Sigma}{\text{AAAA}} A \equiv \mathcal{C}[DPQ] \overset{\Sigma}{\text{AAAAAA}} B,$$

which is a  $\Sigma$ -conversion between  $A', B$ . This proves the claim. Hence by Theorem 3.4,  $\Sigma^* \models CR$ .

Now suppose UN fails for  $\Sigma$ . I.e. there are normal forms  $N_1, N_2$  such that  $N_1 \not\equiv N_2$  but  $N_1 =_{\Sigma} N_2$ . Suppose  $N_1, N_2$  are moreover chosen such that  $|N_1| + |N_2|$  (the sum of the lengths) is minimal.

(\*\*) Then  $N_1, N_2$  contain no subterm  $\mathcal{D}AB$  such that  $A =_{\Sigma} B$ . For, suppose say  $N_1$  contains such a  $\mathcal{D}AB$ . Then obviously  $A, B$  are in normal form (since  $N_1$  is),  $A \not\equiv B$  (since  $N_1$  contains no  $\mathcal{D}$ -redex) and  $|A| + |B| < |N_1|$ . This would contradict the minimality of  $N_1, N_2$ .

Since  $N_1 =_{\Sigma} N_2$ , we have a  $\Sigma$ -conversion  $\Gamma: N_1 \overset{\Sigma}{\text{AAAA}} N_2$ . After replacing each  $\mathcal{D}$  by  $\mathcal{D}^*$ , this yields a  $\Sigma^*$ -conversion  $\Gamma^*: N_1^* \overset{\Sigma^*}{\text{AAAA}} N_2^*$ . Now  $N_1^*$  and  $N_2^*$  are also  $\Sigma^*$ -normal forms; that there are no  $\mathcal{D}^*$ -redexes was remarked in (\*\*). Moreover,  $N_1^* \not\equiv N_2^*$  since  $N_1 \not\equiv N_2$ .

So  $\Sigma^* \not\models UN$ . But this contradicts our earlier remark that  $\Sigma^* \models CR$  (since  $CR \Rightarrow UN$ ). Hence  $\Sigma \models UN$ .  $\square$

#### 4. SOME POSITIVE CR-RESULTS FOR NON-LEFT-LINEAR CRS'S

If  $\Sigma$  is a non-left-linear, but strongly normalizing CRS, then CR holds (provided  $\Sigma \models WCR$ ) by Newman's Lemma. However, consider the TRS  $\Sigma$  with constants  $\omega, \mathcal{D}$  and rules  $\omega Z \rightarrow .ZZ$  and  $\mathcal{D}ZZ \rightarrow Z$ . Then  $\Sigma \not\models SN$ ; e.g.  $\omega\omega$  or  $\omega(\mathcal{D}\omega\omega)$  reduce to themselves. Yet  $\Sigma$  seems clearly CR; but even for this simple TRS the proof is problematic.

In this subsection we give some positive information on the CR-property for non-left-linear CRS's; this will also cast more light on the previous CR-counterexamples. One of these results (5.6(iii) and 5.7(i)) answers a question (or rather, suggestion) in O'DONNELL [77] ('Further Research'

p.103, (2) (b).)

**4.1. DEFINITION.** Let  $\Sigma$  be a CRS and let  $M \in \text{Ter}(\Sigma)$ . Then  $\text{CR}(M)$ , "M is CR", iff  $\forall A, B, C$

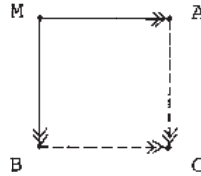

(So  $\text{CR}(M)$  says that the CR-property holds locally, at  $M$ .)

**4.2. NOTATION.** Let  $\Delta_k$  be the CRS with constants  $\mathcal{D}_k, E$  and rules  $\mathcal{D}_k ZZ \rightarrow EZ$ . Likewise  $\Delta_s$  has the constants  $\mathcal{D}_s, E$  and the rule  $\mathcal{D}_s ZZ \rightarrow EZ$ ; and  $\Delta_h$  has the constant  $\mathcal{D}_h$  and the rule  $\mathcal{D}_h ZZ \rightarrow Z$ . (Sometimes we will revert to our previous 'abus de langage' of writing  $\Sigma \oplus \mathcal{D}_i$  ( $i = k, s, h$ ) where  $\Sigma \oplus \Delta_i$  is meant.)

**4.3. DEFINITION.** Let  $\Sigma$  be a CRS and consider  $\Sigma \oplus \Delta_i$  where  $i = h, k, s$ .

(i) A  $\mathcal{D}$ -preredex  $R_D$  is a  $\Sigma \oplus \Delta_i$ -term of the form of  $\mathcal{D}_i AB$ . A chain of  $\mathcal{D}$ -preredexes (of length  $n$ ), or  $\mathcal{D}$ -chain, in a term  $M$  is a sequence

$$M \geq R_D \geq R'_D \geq R''_D \geq \dots \geq R_D^{(n)}$$

for some  $n$ .

(ii)  $|M|_D :=$  the maximal length of chains of  $\mathcal{D}$ -preredexes in  $M$ .

$\|M\|_D := \max\{|N|_D \mid M \rightarrow N\}$ ; possibly  $\|M\|_D = \infty$ . Here  $\rightarrow$  is reduction in  $\Sigma \oplus \Delta_i$ . We call  $\|M\|_D$  the ' $\mathcal{D}$ -norm' of  $M$ .

**4.3.1. EXAMPLE.** In  $\text{CL} \oplus \Delta_1$ , let  $M_1 \equiv \text{ID}(\text{DII})(\mathcal{D}(\text{DII})1)$  and  $M_2 \equiv \text{CA}$  as in the CR-counterexample for  $\text{CL} \oplus \Delta_1$  above.

Then  $|M_1|_D = 2$ ,  $\|M_1\|_D = 3$ ,  $|M_2|_D = 1$ , and  $\|M_2\|_D = \infty$ .

**4.3.2. REMARK.** (i)  $M \rightarrow N \Rightarrow \|M\|_D \geq \|N\|_D$ .

(ii) If  $\|M\|_D$  is finite, then:  $M \rightarrow \mathcal{C}[\mathcal{D}PQ] \Rightarrow \|P\|_D, \|Q\|_D < \|M\|_D$ .

**4.4. THEOREM.** Let  $\Sigma$  be a regular TRS. Then:

(i) for all  $M \in \text{Ter}(\Sigma \oplus \Delta_k)$ ,  $\|M\|_D < \infty \Rightarrow \text{CR}(M)$

(ii) likewise for  $\Sigma \oplus \Delta_s$ .

PROOF. (i) The proof is by induction on  $\|M\|_D$ .

The *basis step*,  $\|M\|_D = 0 \Rightarrow CR(M)$ , follows easily from  $\Sigma \models CR$ .

*Induction step.* Induction hypothesis:  $\|M\|_D < n \Rightarrow CR(M)$ .

Now let  $M$  be a term such that  $\|M\|_D = n+1$ .

Let two reductions of  $M$ ,  $\mathcal{R}_1$  and  $\mathcal{R}_2$ , be given; see figure.

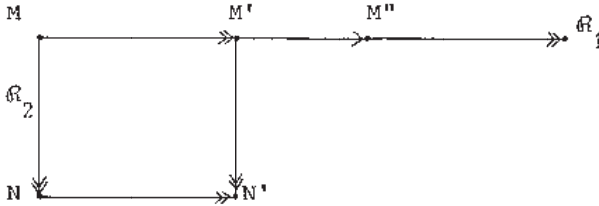

Suppose we have already found a common reduct  $N'$  of  $N$  and  $M'$ . If the next step in  $\mathcal{R}_1$ ,  $M' \rightarrow M''$ , is a  $\Sigma$ -reduction step, we can find a common reduct of  $N'$  and  $M''$  by Lemma 3.1.

The other case is as in the next figure:  $M' \rightarrow M''$  is a  $\mathcal{D}_k$ -step. By Proposition 1.2.7(ii), which evidently holds also with  $\lambda$  replaced by  $\Sigma$  (it is easy to verify that an analogon of Cor.I.6.13 as used there, holds for CRS's), we can postpone the  $\mathcal{D}$ -steps in  $M' \rightarrow N'$ .

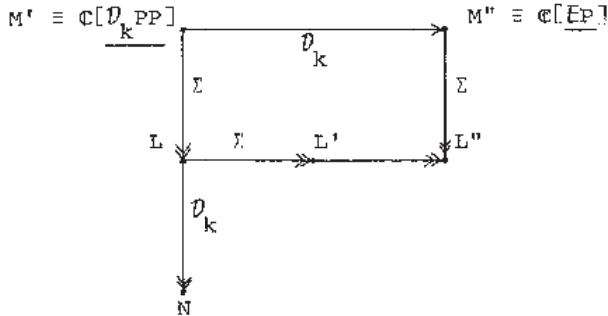

Now underline the  $\mathcal{D}_k$ -redex  $\mathcal{D}_k PP$  which is contracted in the step  $M' \rightarrow M''$ , and also the descendants of that redex in the reduction  $M' \rightarrow L \rightarrow L'$ . (Since this is a  $\Sigma$ -reduction, this makes sense: the concept 'descendant' is defined for regular CRS's. Underline moreover the contractum  $EP$  in  $M''$  and all its descendants in  $M'' \rightarrow L''$ ; here  $L'$  and  $L''$  are found as in the proof of Lemma 3.1. So the  $\Sigma$ -reduction steps in  $L \rightarrow L'$  take place inside underlined subterms, and we have:

$$L \equiv \mathbb{C}[\underline{D_{P_1 Q_1}}, \dots, \underline{D_{P_m Q_m}}]$$

$$L' \equiv \mathbb{C}[\underline{D_{R_1 R_1}}, \dots, \underline{D_{R_m R_m}}]$$

$$L'' \equiv \mathbb{C}[\underline{E_{R_1}}, \dots, \underline{E_{R_m}}]$$

for some  $m$ -ary context  $\mathbb{C}[\dots]$  and terms as displayed. (An  $m$ -ary context is a context having  $m$  'holes', e.g.  $\square S(I\square\square)$  is a ternary context.)

Now consider in  $L$  all  $\mathcal{D}$ -preredexes (underlined or not) which are going to be contracted in the reduction  $L \twoheadrightarrow N'$ . To be precise: the  $\mathcal{D}$ -preredexes having a descendant which is contracted in  $L \twoheadrightarrow N'$ . (In fact, we have not defined 'descendants' for irregular CRS's; but we can use for the purpose of this proof the following definition.

Let  $\Delta_k^*$  be the regular CRS with constants  $D_k^*$ ,  $E$  and the rule  $D_k^* Z_1 Z_2 \rightarrow E Z_1$ . Then for  $\Sigma \oplus \Delta_k^*$  descendants are defined; and now the concept of descendants in  $\Sigma \oplus \Delta_k^*$  is induced in the obvious way.)

We will mark those  $\mathcal{D}$ -preredexes, which will be contracted in  $L \twoheadrightarrow N'$ , by an underlining       . Next, consider the underlined  $\mathcal{D}$ -preredexes (by        as well as       ) which are maximal w.r.t.  $\subseteq$ . Then

$$L \equiv \mathbb{C}'[\underline{\underline{D_{U_1 V_1}}}, \dots, \underline{\underline{D_{U_\ell V_\ell}}}]$$

for some  $\ell$ -ary context  $\mathbb{C}'$ ; here        is        or        or       .

Note that the       -underlined  $\mathcal{D}$ -preredexes are pairwise disjoint, trivially. Since  $L \twoheadrightarrow L'$  is a  $\Sigma$ -reduction taking place inside       -underlined  $\mathcal{D}$ -preredexes and in  $L' \twoheadrightarrow L''$  only       -underlined  $\mathcal{D}$ -redexes are contracted, and since        covers       , the context  $\mathbb{C}'[\dots]$  remains unchanged in  $L''$ .

Therefore we can write

$$L \equiv \mathbb{C}'[D_1, \dots, D_\ell] \quad \text{where } D_j \equiv \underline{\underline{D_{U_j V_j}}},$$

$$L'' \equiv \mathbb{C}'[F_1, \dots, F_\ell] \quad \text{for some } F_j,$$

$$N' \equiv \mathbb{C}'[D'_1, \dots, D'_\ell] \quad \text{for some } D'_j \ (j = 1, \dots, \ell).$$

Hence it is sufficient to prove that  $D'_j \downarrow F_j$  ( $j = 1, \dots, \ell$ ). We may suppose that the descendants of the  $D_j$  ( $j = 1, \dots, \ell$ ) are the last ones to be contracted in  $L \twoheadrightarrow N'$ . (The proof is easy: replace if necessary the

reduction  $D_j \equiv \mathcal{D}U_j V_j \xrightarrow{\Sigma} \mathcal{D}W_j W_j \xrightarrow{\mathcal{D}} EW_j \xrightarrow{\mathcal{D}} EW'_j \equiv D'_j$  by the reduction  $\mathcal{D}U_j V_j \xrightarrow{\Sigma} \mathcal{D}W_j W_j \xrightarrow{\mathcal{D}} \mathcal{D}W'_j W'_j \xrightarrow{\mathcal{D}} EW'_j \equiv D'_j$ , etc.) This is not an essential step, however.

Now, according to the relative position in  $D_j$  of the  $\underline{\quad}$  and  $\sim$  underlining, we distinguish the following cases.

CASE 1.  $D_j \equiv \mathcal{D}\underline{P_j Q_j}$ . So the reductions

$$\begin{array}{c} L \xrightarrow{\quad} L'' \\ \downarrow \\ N' \end{array}$$

contain the following reductions of  $D_j$ :

$$\begin{array}{ccc} L \supseteq D_j \equiv \mathcal{D}P_j Q_j & \xrightarrow{\Sigma} & \mathcal{D}R_j R_j \xrightarrow{\mathcal{D}} ER_j \equiv F_j \subseteq L'' \\ & \downarrow \mathcal{D} & \uparrow \mathcal{D} \\ & \mathcal{D}SS & L' \\ & \downarrow \mathcal{D} & \\ D'_j \equiv ES \subseteq N' & & \end{array}$$

Since  $\|P_j\|_D \leq n$  by Remark 4.3.2, the induction hypothesis yields a common reduct of  $S$  and  $R_j$  as follows:

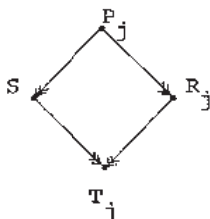

Hence also  $D'_j \equiv ES$  and  $F_j \equiv ER_j$  have a common reduct.

CASE 2.  $D_j \equiv \mathcal{D}P_j Q_j$ ;  $P_j$  and  $Q_j$  may contain  $\sim$ . Now we have the situation:

$$\begin{array}{ccc} L \supseteq D_j \equiv \mathcal{D}P_j Q_j & \xrightarrow{\Sigma} & \mathcal{D}R_j R_j \xrightarrow{\mathcal{D}} ER_j \equiv F_j \subseteq L'' \\ & \downarrow \mathcal{D} & \uparrow \mathcal{D} \\ & \mathcal{D}SS & L' \\ N' \supseteq D'_j \equiv \mathcal{D}SS' & & \end{array}$$

Again, since the  $\mathcal{D}$ -norms of the involved terms are  $\leq n$ , we can construct by the induction hypothesis a common reduct  $T_j$  as follows:

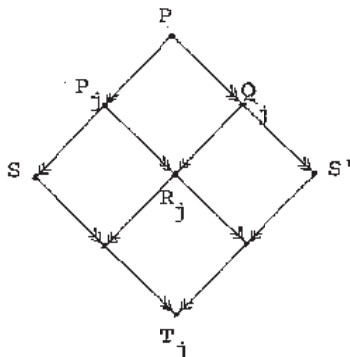

Hence  $D_j' \equiv DSS' \xrightarrow{D} DT_jT_j \xrightarrow{D} ET_j$  and  $F_j \equiv ER_j \xrightarrow{D} ET_j$ .

CASE 3.  $D_j \equiv \mathcal{D}U_jV_j$ ;  $\mathcal{D}U_jV_j$  is not  $\underline{\quad}$ -underlined, but  $U_j, V_j$  may contain  $\underline{\quad}$ . (Note that  $\mathcal{D}U_jV_j$  is not a proper subterm of a  $\mathcal{D}P_iQ_i$  for some  $i$ , by the maximality condition for the  $D_j$ .) So we have the following situation:

$$\begin{array}{ccc}
 L \supseteq D_j \equiv \mathcal{D}U_jV_j & \xrightarrow{D} & \mathcal{D}U_j'V_j' \equiv F_j \subseteq L'' \\
 \downarrow D & & \\
 DSS & & \\
 \downarrow & & \\
 N' \supseteq D_j' \equiv Es. & & 
 \end{array}$$

Now we can find again a common reduct  $T_j$ :

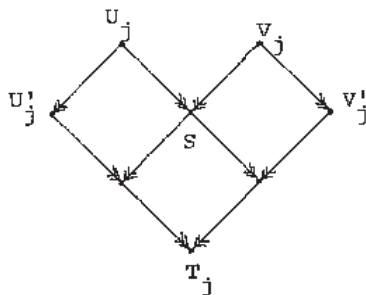



Hence  $F_j \equiv \mathcal{D}_j' V_j' \rightarrow \mathcal{D}_j T_j \rightarrow E T_j$  and  $D_j' \equiv E S \rightarrow E T_j$ . So in all three cases we have  $F_j \downarrow D_j'$  ( $j = 1, \dots, \ell$ ); hence  $L'' \downarrow N'$ .

(ii) For  $\Sigma \oplus \Delta_s$  the proof is entirely similar to (i).  $\square$

4.5. REMARK. Note that indeed the terms in the previous CR-counterexamples have an infinite  $\mathcal{D}$ -norm.

4.6. REMARK. In fact we have proved the following stronger proposition, as follows easily by inspection of the proof of Theorem 4.4:

4.6.1. PROPOSITION. Let  $\Sigma$  be a regular TRS and let  $M \in \text{Ter}(\Sigma \oplus \Delta_1)$  ( $i = k, s$ ) be such that for all  $N, A, B: M \rightarrow N \supseteq \mathcal{D}AB$  implies  $\text{CR}(A), \text{CR}(B)$ . Then  $\text{CR}(M)$ .

4.7. REMARK. (i) Let  $\Sigma$  be CL extended with  $\mathcal{D}_k, E$  and the reduction rule:  $\mathcal{D}_k M M \rightarrow E M$  if  $M$  is strongly normalizing (SN), w.r.t. CL - as well as  $\mathcal{D}$ -reduction. Then  $\Sigma \models \text{CR}$ .

To see this, note that  $M \in \text{SN} \Leftrightarrow \text{CR}(M)$  by Newman's Lemma; then the proof of Theorem 4.4 applies without change. Likewise for  $\mathcal{D}_s$ .

(ii) A similar proposition holds when the restriction in (i) on  $M$  is replaced by:

"if  $M$  does not contain the constant  $\mathcal{D}_k$ " (resp.  $\mathcal{D}_s$ ). For, then we have  $\text{CR}(M)$  at once, since  $\text{CL} \models \text{CR}$ .

In order to state the following corollary of Theorem 4.4, first a definition.

4.8. DEFINITION. (i) If  $H \in \text{Mter}(\Sigma)$ , then  $d(H)$  (the *depth* of  $H$ ) is the maximal length of branches of  $\tau(H)$ , the term formation tree of  $H$  as in 1.7. (Par abus de langage, we will write  $d(H) = d(\tau(H))$ .) E.g.

$$d(Sz_1 z_2 z_3) = d\left( \begin{array}{c} S \\ / \quad | \quad \backslash \\ z_1 \quad z_2 \quad z_3 \end{array} \right) = 1$$

and

$$d(z_1 z_3 (z_2 z_3)) = d\left( \begin{array}{c} z \\ / \quad \backslash \\ z_3 \quad z_2 \\ | \\ z_3 \end{array} \right) = 2.$$

(ii) Call a reduction rule  $H \rightarrow H'$  *diminishing* if  $d(H) \geq d(H')$  and call the CRS  $\Sigma$  *diminishing* if all its reduction rules are.

4.9. COROLLARY of Theorem 4.4.

Let  $\Sigma$  be a *diminishing regular* TRS. Then  $\Sigma \oplus \Delta_i \models \text{CR}$  ( $i = k, s$ ).

PROOF. Note that the rules for  $\mathcal{D}_i$  ( $i = k, s$ ) are *diminishing*:

$$\begin{array}{ccc} d(\begin{array}{c} \mathcal{D}_k \\ \swarrow \quad \searrow \\ z \quad z \end{array}) \geq d(\begin{array}{c} E \\ | \\ z \end{array}) & \text{and} & d(\begin{array}{c} \mathcal{D}_s \\ \swarrow \quad \searrow \\ z \quad z \end{array}) > d(E). \end{array}$$

Hence  $\Sigma \oplus \Delta_i$  ( $i = k, s$ ) is *diminishing*. Therefore, no  $M \in \text{Ter}(\Sigma \oplus \Delta_i)$  can have an infinite  $\mathcal{D}$ -norm.  $\square$

4.10. EXAMPLES. (i) Let  $\Sigma$  have constants  $\omega, \mathcal{D}, E$  and the rules  $\omega z \rightarrow zz$  and  $\mathcal{D}zz \rightarrow E z$ . Then  $\Sigma \models \text{CR}$ .

(ii) Let  $\text{CL}^*$  have constants  $K, S^*$  and rules

$$Kz_1 z_2 \rightarrow z_1 \quad \text{and} \quad S^* z_1 z_2 z_3 \rightarrow z_1 z_3 z_2 z_3.$$

Then  $\text{CL}^* \oplus \Delta_i \models \text{CR}$  ( $i = k, s$ ).

(iii) Let  $\text{CL}^{**}$  have constants  $K, S^{**}, Q$  and rules

$$Kz_1 z_2 \rightarrow z_1 \quad \text{and} \quad S^{**}(Qz_1)z_2 z_3 \rightarrow z_1 z_3 (z_2 z_3).$$

Then  $\text{CL}^{**} \oplus \Delta_i \models \text{CR}$  ( $i = k, s$ ).

4.11. DEFINITION. Let  $\Sigma$  be a regular TRS. Then  $\Sigma \oplus \Delta_i^{(2)}$  ( $i = k, s, h$ ) will denote the substructure of  $\Sigma \oplus \Delta_i$  where every  $\mathcal{D}_i$  is the head of a  $\mathcal{D}$ -preredex (i.e. every  $\mathcal{D}_i$  has two arguments).

E.g. if  $\Sigma$  is CL, then  $SK(DII)$  and  $\mathcal{D}(DII)SK)KK$  are  $\Sigma \oplus \Delta_i^{(2)}$ -terms, but  $SK(DI)$  or  $SKD$  are not.

(Alternative, inductive definition of  $T = \text{Ter}(\Sigma \oplus \Delta_i^{(2)})$ :

(1)  $\text{Ter}(\Sigma) \subseteq T$ , (2)  $A, B \in T \Rightarrow AB, \mathcal{D}AB \in T$ .)

4.12. COROLLARY of Theorem 4.4.

Let  $\Sigma$  be a *regular* TRS. Then  $\Sigma \oplus \Delta_i^{(2)} \models \text{CR}$  ( $i = k, s$ ).

PROOF. If  $M \rightarrow N$  for  $M, N \in \text{Ter}(\Sigma \oplus \Delta_i^{(2)})$  ( $i = k, s$ ), then  $\|M\|_D \geq \|N\|_D$  as one easily verifies. Hence  $|M|_D = \|M\|_D < \infty$ .  $\square$

4.13. REMARK. Consider a regular TRS as in HUET [78], where a TRS is written in 'function notation'; e.g. instead of our  $PZ_1Z_2 \rightarrow Z_1$  the notation in HUET [78] would read  $P(Z_1, Z_2) \rightarrow Z_1$ . Now, writing  $\Delta_k^f$  for the TRS having as only rule  $D_k(Z, Z) \rightarrow E(Z)$  and  $\Delta_s^f$  for the TRS with the rule  $D_s(Z, Z) \rightarrow E$ , Corollary 4.12 is equivalent to the proposition that for every regular TRS  $\Sigma^f$  as in HUET [78], we have  $\Sigma^f \oplus \Delta_k^f \vdash \text{CR}$  ( $i = k, s$ ). (Below we will generalize Corollary 4.12 to the case  $i = h$ .)

This might seem somewhat paradoxical in view of e.g.  $\text{CL} \oplus \Delta_k \not\vdash \text{CR}$ ; the explanation is that the 'function-notation' version  $(\text{CL} \oplus \Delta_k)^f$  cannot be written as a 'direct sum'  $\text{CL}^f \oplus \Delta_k^f$ . See HUET [78], who gives as  $\text{CL}^f$ :

$$\begin{aligned} A(A(S, Z_1), Z_2), Z_3) &\rightarrow A(A(Z_1, Z_3), A(Z_2, Z_3)) \\ A(A(K, Z_1), Z_2) &\rightarrow Z_1 \end{aligned}$$

where  $A$  stands for application. Now  $(\text{CL} \oplus \Delta_k)^f$  would be the TRS having the two preceding rules plus  $A(A(D, Z), Z) \rightarrow E(Z)$ .

We will now generalize some of the preceding results to  $\Delta_h$  and SP. This will be done via a lemma which may be of independent interest.

## 5. THE 'BLACK BOX' LEMMA

Consider an extension  $\Sigma$  of CL by some new constants and some new reduction rules. The rules need not to be regular, and may be quite 'pathological'. Now consider a  $\Sigma$ -term  $M \equiv C[\square_1, \dots, \square_n]$  where  $C[\dots]$  is an  $n$ -ary CL-context (i.e. a CL-term with  $n$  'holes') and where the  $\square_i$  ( $i = 1, \dots, n$ ) are  $\Sigma$ -terms, possibly containing new constants. Suppose we are not interested in the precise content of the  $\square_i$  (so they are 'black boxes'), but know already that  $\text{CR}(\square_i)$  and moreover, suppose that a black box can only be "opened" (and hence interact with its context) when its content is a CL-term (not containing new constants).

Then, we claim,  $\text{CR}(M)$  holds.

A refinement, which we will prove and use below, of this claim is that a black box, when opened, may yield a CL-context of other black boxes - but only when the latter are of lesser 'order' (a natural number) than the

former.

5.1. DEFINITION. (i)  $CL^n$  is an extension of  $CL$  with a set of constants  $\{\square_i^n \mid n, i \in \mathbb{N}\}$ ; here  $n$  is called the 'order' of  $\square_i^n$  (and  $i$  can be thought of as the 'internal state' of  $\square_i^n$ ).

(ii) Next to  $CL$ -reduction we have the following kinds of reduction:

(a)  $\square_i^n \xrightarrow[n]{\quad} \square_j^m$  for some  $n, m, i, j$ ; it is required that  $n \geq m$ .

(b)  $\square_i^n \xrightarrow[n]{\quad} \mathbb{C}[\square_{j_1}^{m_1}, \dots, \square_{j_k}^{m_k}]$  for some  $n, i, k, m_1, j_1, \dots, m_k, j_k$ . Here  $\mathbb{C}[\dots]$  is a  $k$ -ary  $CL$ -context. It is required that  $m_1, \dots, m_k < n$ .

A step of kind (a) is called 'internal'; furthermore we say that after a (b)-step the black box  $\square_i^n$  is 'opened'. As always, reduction steps of any kind may occur in an arbitrary context, i.e.  $A \xrightarrow[n]{\quad} B \Rightarrow \mathbb{C}[A] \xrightarrow[n]{\quad} \mathbb{C}[B]$ .

Sometimes we will omit the subscript in  $\xrightarrow[n]{\quad}$ .

(iii) Reduction of kind (a), (b) is required to be CR: internal reduction must satisfy  $WCR^{1,1}$ , i.e.:

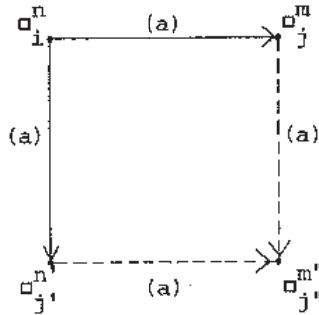

and furthermore we require

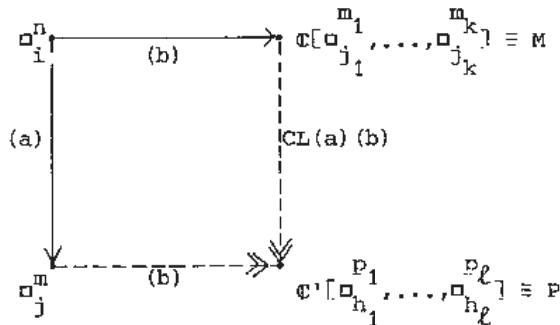

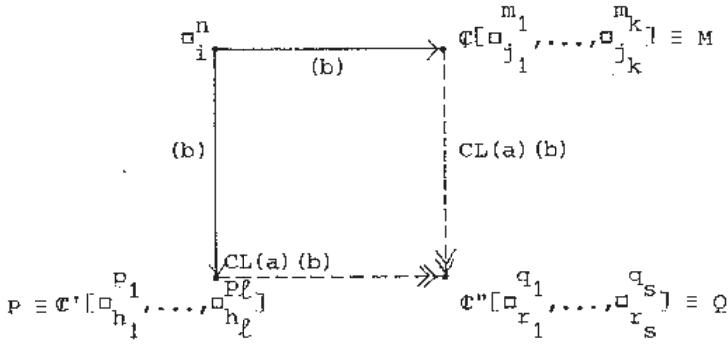

(iv)  $CL\square^n$  is the restriction of  $CL\square$  to terms containing only constants  $\square_i^m$  where  $m < n$ . So  $CL\square^0 = CL$ . If  $M, N \in \text{Ter}(CL\square^n)$  and  $M \xrightarrow{CL(a)(b)} N$ , we write  $M \xrightarrow{n} N$  and call  $M$  an  $\xrightarrow{n}$ -redex. (Warning:  $\xrightarrow{n} \neq \xrightarrow{n}$ )

(v)  $M \xrightarrow{n} N \Rightarrow \mathbb{C}[M] \xrightarrow{n} \mathbb{C}[N]$ , where  $\mathbb{C}[\ ]$  is now a  $CL\square$ -context. (Note that  $\mathbb{C}[M]$  will be in general not an  $\xrightarrow{n}$ -redex, which is  $\in \text{Ter}(CL\square^n)$ .)

5.2. LEMMA. Let  $CL\square$  be an extension of  $CL$  as in the preceding definition. Then  $CL\square \models CR$ .

PROOF. We will prove by induction on  $n$  that  $\xrightarrow{n}$  has the CR-property. Then obviously arbitrary  $CL(a)(b)$ -reduction ( $= \bigcup_{n \in \mathbb{N}} \xrightarrow{n}$ ) is also CR.

Basis. Follows since  $CL\square^0 = CL \models CR$ .

Induction step. Induction hypothesis:

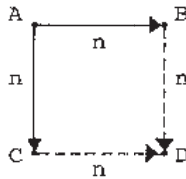

Now consider  $CL\square$ -terms  $A, B, C$  such that  $A \xrightarrow{n+1} B$ ,  $A \xrightarrow{n+1} C$ . These 'steps' consist in fact of  $CL$ -steps,  $\xrightarrow{n}$ -steps, and  $\xrightarrow{m(a)(b)}$ -steps ( $m \leq n$ ). We will now examine the elementary diagrams which arise when these steps are 'confronted'. (We will not explicitly consider the trivial cases in which the two confronted redexes are disjoint.)

CASE I. A  $CL$ -step versus a  $CL$ -step. Trivial.

CASE II. An (a) (b)-step versus an (a) (b)-step. There are three subcases.

(1) (a) vs. (a):

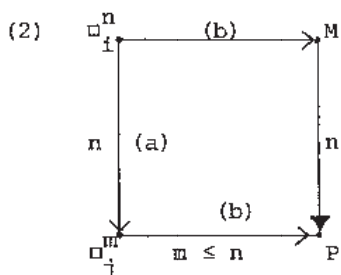
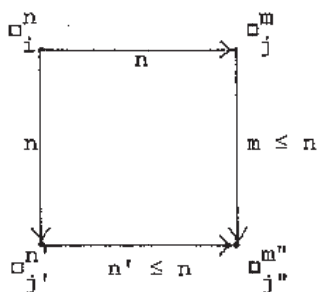

(3)

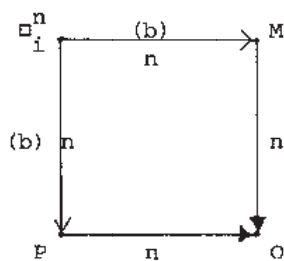

Here P, Q, M are as in the diagrams in Def.5.1.

CASE III. An  $\xrightarrow{n}$ -step versus an  $\xrightarrow{n}$ -step. This case is covered by the induction hypothesis: see the diagram there.

CASE IV. An  $\xrightarrow{n}$ -step versus an  $\xrightarrow{m}$ -step ( $m \leq n$ ).

(1). If  $m < n$ , then the latter step is also an  $\xrightarrow{n}$ -step and we are in the preceding case. So we have then

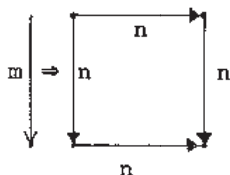

(2). If  $m = n$ , these two steps involve disjoint redexes, since an  $\xrightarrow{n}$ -redex (a  $CL\Box^n$ -term) cannot contain an " $\xrightarrow{n}$ -redex", (i.e. a constant  $\Box_1^n$ ) by definition. So we have

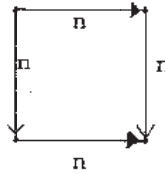

CASE V. A CL-step versus an  $\frac{(a)(b)}{m} \rightarrow$  - step ( $m \leq n$ ). This case is easily analyzed; the elementary diagrams which arise are of the form:

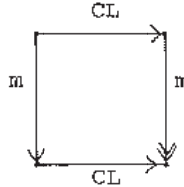

(Here  $\xrightarrow{CL}$  is an S-, K-, or I-step.)

CASE VI. A CL-step versus an  $\xrightarrow{n}$  - step.

Three subcases arise. Let R be the CL-redex and R' the  $\xrightarrow{n}$  - redex.

- (1)  $R \cap R' = \emptyset$ : trivial
- (2)  $R \subseteq R'$ . Then R is also a  $\xrightarrow{n}$  - redex. Hence, by the induction hypothesis:

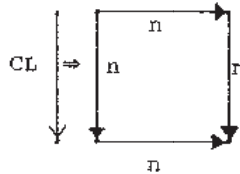

(3) If  $R \not\subseteq R'$ , we distinguish the following sub-subcases.

- (i)  $R \equiv SABC, \quad R' \equiv SAB$
- (ii) "  $R' \equiv SA$
- (iii) "  $R' \subseteq A$
- (iv) "  $R' \subseteq B$
- (v) "  $R' \subseteq C$
- (vi)  $R \equiv KAB, \quad R' \equiv KA$
- (vii) "  $R' \subseteq A$
- (viii) "  $R' \subseteq B$
- (ix)  $R \equiv IA, \quad R' \subseteq A.$

We consider the two most noteworthy cases: (i) and (v).

(i)

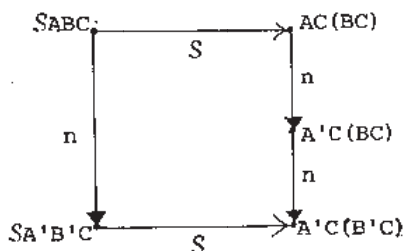

(v)

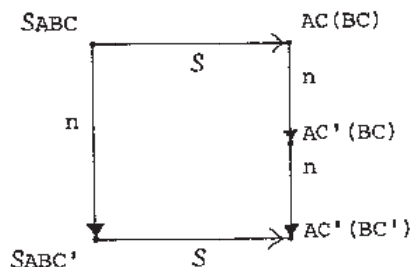

The other seven cases are even simpler: they involve no splitting of steps.

The conclusion is that the CL-steps (in fact only the  $S$ -steps) are the only ones who have the power to split the other arrow in an elementary diagram. So by a routine argument and an appeal on the lemma of Hindley-Rosen (I.5.7), reductions involving CL-,  $\xrightarrow{n}$ -,  $\xrightarrow{m}$  ( $m \leq n$ )-steps are CR. I.e. we have proved

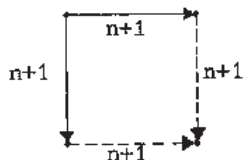

Hence  $CL \sqsubseteq \models CR$ .  $\square$

5.3. REMARK. It is not hard to check that the 'black box' lemma 5.2 also holds for  $\lambda$  instead of CL, or for other regular CRS's in general.

5.4. EXAMPLE. (i) A simple application of the black box lemma for  $\lambda$  is the well-known result (obtained by MITSCHKE in an unpublished note and independently by us) that  $\lambda \oplus (\Omega \rightarrow M) \models CR$ , where  $\Omega \equiv (\lambda x.xx)(\lambda x.xx)$  and  $M$  is an arbitrary fixed term. (Cf. BAETEN-BOERENBOOM [78]) (Just put  $\Omega$  in a box, which can only be opened after its reduction to  $M$ ; the CR-requirements for the boxes hold trivially.) This example is only meant as an illustration, since it is easy to give a more straightforward CR-proof.

Before stating some corollaries of Lemma 5.2, some notation:



5.5. NOTATION and DEFINITION. (i)  $CL \oplus \mathcal{D}_h^{(2)}$  is already defined in 4.11. A notational variant  $CL \oplus \mathcal{D}_h(\cdot)$  is obtained by defining the set  $T$  of terms inductively as follows:

(1)  $I, K, S \in T$ , (2)  $A, B \in T \Rightarrow AB, \mathcal{D}_h(A, B) \in T$ . Next to  $CL$ -reduction there is the rule  $\mathcal{D}_h(A, A) \rightarrow A$ .

(ii)  $\lambda \oplus \mathcal{D}_h^{cl}$  is the substructure of  $\lambda \oplus \mathcal{D}_h$  where in every  $\mathcal{D}_h AB$  one requires  $A, B$  to be closed. So the set  $T$  of terms is defined by

(1)  $x_i \in T$  (2)  $A, B \in T \Rightarrow AB, \lambda x.A \in T$  (3)  $A, B \in T$  and closed  $\Rightarrow \mathcal{D}_h^{cl} AB \in T$ .

(Notational variant:  $\mathcal{D}_h^{cl}(A, B)$  instead of  $\mathcal{D}_h^{cl} AB$ .)

(iii)  $\lambda \oplus (\text{if } \dots \text{ then } \dots \text{ else } \dots)$ , or its notational variant  $\lambda \oplus \mathcal{B}(\cdot, \cdot, \cdot)$ , and  $\lambda \oplus \mathcal{B}$  are already defined in 1.2.11.(v) (3). Likewise for  $CL$ .

(iv) Analogous to  $\lambda \oplus \mathcal{D}_h^{cl}$  we define  $\lambda \oplus \mathcal{B}^{cl}$ .

Now we have the following situation:

5.6. THEOREM. (i)  $CL \oplus \mathcal{D}_h(\cdot, \cdot) \models CR$

(ii)  $\lambda \oplus \mathcal{D}_h^{cl}(\cdot, \cdot) \models CR$

(iii)  $CL \oplus \mathcal{B}(\cdot, \cdot, \cdot) \models CR$

(iv)  $\lambda \oplus \mathcal{B}^{cl}(\cdot, \cdot, \cdot) \models CR$ .

PROOF. (i) Consider  $CL \oplus \mathcal{D}_h(\cdot, \cdot)$  or its notational equivalent  $CL \oplus \mathcal{D}_h^{(2)}$ . Let  $M \in \text{Ter}(CL \oplus \mathcal{D}_h^{(2)})$  and put the maximal subterms of the form  $\mathcal{D}AB$  (a maximal  $\mathcal{D}$ -preredex) in boxes and let  $n = |\mathcal{D}AB|_{\mathcal{D}}$  (see Def.4.3) be the order of such a box  $\boxed{\mathcal{D}AB}^n$ . A box is opened when  $\boxed{\mathcal{D}AB}^n \longrightarrow \boxed{\mathcal{D}CC} \longrightarrow C$ . Obviously  $|C|_{\mathcal{D}} < n$ , i.e.  $C$  is a  $CL$ -context possibly containing boxes of order  $< n$ . We have to prove the  $CR$ -requirements for the boxes, as stated in Def.5.1.(iii). This will be done by induction on the order  $n$ .

Basis.  $n = 1$ : follows by a simple argument from  $CL \models CR$ , since then  $A, B$  in  $\boxed{\mathcal{D}AB}^1$  are  $CL$ -terms.

Induction step. Induction hypothesis: the restriction  $\Sigma_n$  of  $CL \oplus \mathcal{D}_h^{(2)}$  to terms  $M$  such that  $|M|_{\mathcal{D}} < n$  (cf.  $CL^n$  in Def.5.1), is  $CR$ .

Now let  $M$  contain a  $\boxed{\mathcal{D}AB}^n$ . Then  $CR(\mathcal{D}AB)$  by the same argument as used for the basis step, now using  $\Sigma_n \models CR$  and noting that  $A, B \in \text{Ter}(\Sigma_n)$ .

Hence all the boxes are  $CR$ . The remainder of the proof follows by analogy from the proof of the black box lemma.

(ii) As (i). That in  $\mathcal{D}_h^{cl} AB$  the terms  $A, B$  must be closed, is essential (for this method of proof); otherwise by substitution the  $\mathcal{D}$ -norm (i.e. the

order of the 'black boxes') could increase, as is indeed the case in the previous CR-counterexamples. (See also Remark 5.7.)

(iii) Mutatis mutandis (e.g. the definition of  $\vdash_B$  instead of  $\vdash_D$ ) the proof is similar to that of (i). The ambiguity involved in the reductions  $B \perp AA \rightarrow A$  (by two clauses of the definition of the rules for  $B$ ) is harmless.

(iv) As (iii).  $\square$

5.7. REMARK. (i) Theorem 5.6 holds for any regular CRS instead of  $\lambda$ , CL.

(ii) We expect that analogous results can be given for SP instead of  $\mathcal{D}_h$ .

(iii) Note the correspondence between  $\mathcal{D}_h^{(2)}$  in CL and  $\mathcal{D}_h^{cl}$  in  $\lambda$ . Indeed, if  $\tau$  (or  $\tau'$ ) is the translation from  $\lambda$  to CL as in I.2. then

$\tau(\dots \mathcal{D}_h^{cl} AB \dots) = \text{--} \mathcal{D}_h^{(2)} (\tau A) (\tau B) \text{--}$ . This is not the case for  $\mathcal{D}_h AB$  where  $A, B$  are open; cf. our previous CR-counterexample  $\tau(CA)$  for  $CL \oplus \mathcal{D}_h$ .

(iv) *Warning:*  $\lambda \oplus \mathcal{D}_h^{cl} \models CR$  does not mean that  $\lambda \oplus (\mathcal{D}_h AA \rightarrow A$  if  $A$  is closed)  $\models CR$ . For, the previous CR-counterexample is also a CR-counterexample for the latter restricted system: the two  $\mathcal{D}$ -contractions in that counterexample,  $\mathcal{D}(CA)(CA) \rightarrow CA$ , involved closed terms.

(v) We expect that Theorem 5.6 can be sharpened to yield a result analogous to Theorem 4.4.

5.8. REMARK. The Fixed Point Theorem (cf. I.1.11) for  $\lambda$  and CL can be stated in the following equivalent ways:

(FP)  $\forall F \exists X X \rightarrow FX$

(FP')  $\forall C[ ] \exists X X \rightarrow C[X]$

Note that for the extensions of  $\lambda$  and CL in Theorem 5.6, (FP) stays valid, but (FP') fails. (E.g. in  $CL \oplus \mathcal{D}_h(, )$ , consider  $C[ ] \equiv \mathcal{D}_h(\square, I)$  and note that  $|M|_{\mathcal{D}}$  cannot increase in a reduction of  $M$ .)

In fact, the failure of (FP') is due to the failure of 'Combinatory Completeness' (cf. I.1.10 and I.2.5.3; this property can be phrased as:

(CC)  $\forall C[ , \dots, ] \exists C x_1 \dots x_n \rightarrow C[x_1, \dots, x_n]$  since  $CC \Rightarrow (FP \Leftrightarrow FP')$ , as one easily verifies.

5.9. REMARK. For  $\lambda^T \oplus SP$  (typed  $\lambda$ -calculus plus Surjective Pairing), CR is proved in POTTINGER [79].



## CHAPTER IV

 $\lambda\beta\eta$ -CALCULUS

In this chapter we will derive the main syntactical theorems for  $\lambda\beta\eta$ -calculus. As it turns out, the addition of the so simple  $\eta$ -reduction rule complicates syntactical matters considerably. After the Church-Rosser theorem, which is easily obtained from that for  $\lambda\beta$  and is presented via  $\beta\eta$ -reduction diagrams, we introduce  $\lambda$ -residuals, which have a more pleasant behaviour than the ordinary residuals in  $\beta\eta$ -reductions. For instance, we will show that the Parallel Moves Lemma fails for residuals, but holds for  $\lambda$ -residuals. We make an essential use of  $\lambda$ -residuals and the PM Lemma in this chapter.

By the same method as used for  $\lambda\beta$  in Section 1.9, the Standardization Theorem for  $\lambda\beta\eta$  is proved. Then the Normalization Theorem and Quasi-normalization Theorem are proved for  $\lambda\beta\eta$ . These last two theorems require an extraordinary long proof, compared to the  $\lambda\beta$ -case; nevertheless we felt the effort was worthwhile since firstly the Normalization Theorem is a very 'natural' theorem, and secondly since some of the lemma's used in the proof, seem to be of independent interest.

This chapter was inspired by work of R. Hindley. It answers some open problems mentioned in HINDLEY [78], namely whether the Standardization Theorem (there called: Strong Standardization) and the (Quasi-) Normalization theorem hold for  $\lambda\beta\eta$ .

1. THE CHURCH-ROSSER THEOREM FOR  $\lambda\beta\eta$ -CALCULUS

1.1. DEFINITION. Let the set of  $\lambda$ -terms,  $\text{Ter}(\lambda)$ , as in Def. I.1.1. be given. In addition to  $\beta$ -reduction we define  $\eta$ -reduction, as follows:

$$\mathfrak{C}[\lambda x.Ax] \xrightarrow{\eta} \mathfrak{C}[A]$$

for all  $A \in \text{Ter}(\lambda)$  such that  $x \notin \text{FV}(A)$ , and all contexts  $\mathbb{C}[\ ]$ .

A term of the form  $\lambda x.Ax$  where  $x \notin \text{FV}(A)$  is called an  $\eta$ -redex. The transitive reflexive closure of  $\xrightarrow{\eta}$  is  $\xrightarrow{\eta^*}$ . By ' $\lambda\beta\eta$ -calculus' we mean the reduction system

$$\lambda\beta\eta = \langle \text{Ter}(\lambda), \xrightarrow{\beta}, \xrightarrow{\eta} \rangle.$$

The union  $\xrightarrow{\beta} \cup \xrightarrow{\eta}$  is written as  $\xrightarrow{\beta\eta}$  or just  $\longrightarrow$ .

## 1.2. CONSTRUCTION OF $\beta\eta$ -REDUCTION DIAGRAMS

Let coinital  $\beta\eta$ -reductions  $\mathcal{R}_1 = A \longrightarrow \dots \longrightarrow B$  and  $\mathcal{R}_2 = A \longrightarrow \dots \longrightarrow C$  be given. As in I.6.1 we will try to find a common  $\beta\eta$ -reduct  $D$  of  $B, C$  by constructing the reduction diagram  $\mathcal{D}(\mathcal{R}_1, \mathcal{R}_2)$ . In most cases it is obvious how the diagram construction for  $\beta$ -reductions in I.6.1 is to be extended to include  $\eta$ -reductions. We will mention therefore only the two noteworthy cases:

$$(I) \quad \begin{array}{ccc} \mathbb{C}[(\lambda x.Ax)B] & \xrightarrow[\beta]{\lambda x} & \mathbb{C}[AB] \\ \lambda x \downarrow \eta & & \downarrow \text{(trivial or 'empty' step)} \\ \mathbb{C}[AE] & \text{-----} & \mathbb{C}[AB] \end{array}$$

$$(II) \quad \begin{array}{ccc} \mathbb{C}[\lambda x.(\lambda y.A(y))x] & \xrightarrow[\beta]{\lambda y} & \mathbb{C}[\lambda x.A(x)] \\ \lambda x \downarrow \eta & & \downarrow \\ \mathbb{C}[\lambda y.A(y)] & \text{-----} & \mathbb{C}[\lambda x.A(x)] \end{array}$$

Here in (I), (II)  $x \notin \text{FV}(A)$ . In the sequel we will often omit this condition and assume it tacitly. Note that in (II) we identify the  $\alpha$ -equivalent terms  $\lambda y.A(y)$  and  $\lambda x.A(x)$ .

So in  $\beta\eta$ -reduction diagrams we encounter the following types of elementary diagrams: the ones which are already mentioned for  $\lambda\beta$  (see I.6.1.1), plus

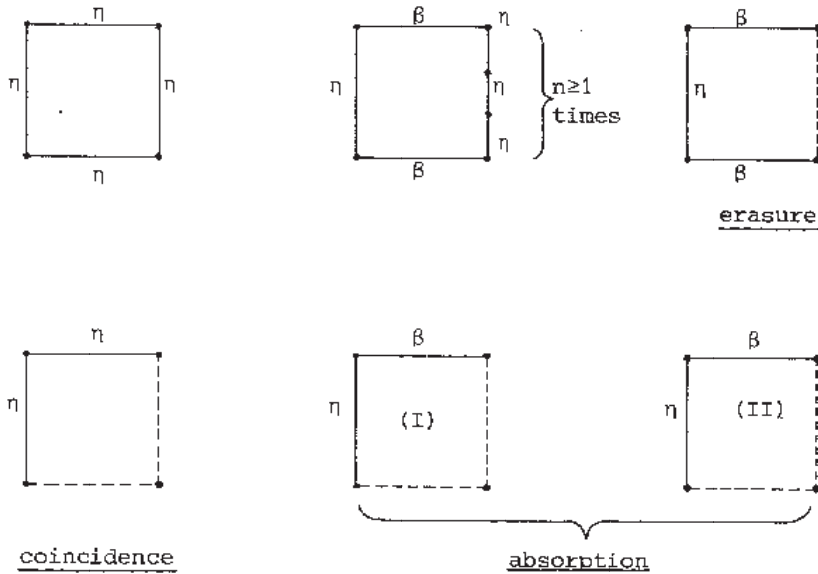

Here (I), (II) in the e.d.'s of the absorption type refer to (I), (II) above.

It is now easy to extend the strong version of the Church-Rosser theorem  $CR^+$  (Theorem I.6.9) to the present case:

### 1.3. THEOREM (Church-Rosser).

*Every diagram construction in  $\lambda\beta\eta$  terminates.*

PROOF. Consider a square which is determined by one step in  $\mathcal{R}_1$  resp.  $\mathcal{R}_2$ :

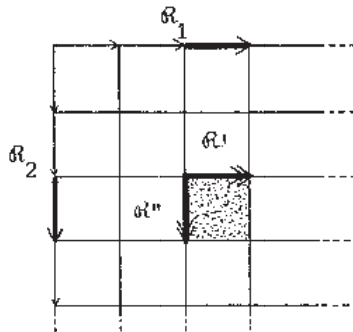

Since  $\beta$ -steps propagate as  $\beta$ -steps (or  $\emptyset$ -steps) and similarly for  $\eta$ -steps,  $\mathcal{R}'$  consists entirely of  $\beta$ -steps + possibly  $\emptyset$ -steps, or entirely of  $\eta$ -steps + possibly  $\emptyset$ -steps. Similarly for  $\mathcal{R}''$ .

In all 4 resulting cases it is easy to show that the construction of  $\mathcal{D}(\mathcal{R}'\mathcal{R}'')$  terminates, using in one case the termination of  $\beta$ -diagrams

(Thm.I.6.9) and in the other 3 cases that  $\eta$ -reductions have no 'splitting effect':

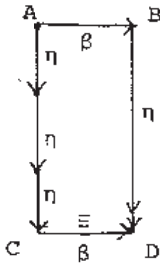

I.e.  $\forall A, B, C, D [A \xrightarrow{\beta} B \ \& \ A \xrightarrow{\eta} C \Rightarrow B \xrightarrow{\eta} D \ \& \ (C \equiv D \vee C \xrightarrow{\beta} B)]$ .

This fact follows at once by inspection of the e.d.'s in 1.2.  $\square$

1.3.1. REMARK. Just as for the case of  $\lambda\beta$ , one can prove that if  $\mathcal{R}'$  consists of  $\beta$ -steps, it is a complete  $\beta$ -development (Def.I.6.6). This is proved in Propositions 5.1 and 5.3(i) below.

## 2. RESIDUALS

2.1. The definition of residuals for  $\lambda\beta\eta$  is as in CURRY-FEYS [58] p.117,118. We repeat the 'critical cases' of this definition.

Let  $M \xrightarrow{R} M'$  where  $R \subseteq M$  is a  $\beta$ - or  $\eta$ -redex, and let  $S \subseteq M$  be a redex whose residuals in  $M'$  we want to define. It is immediately clear what the residuals of  $S$  in  $M'$  should be, except in the following cases.

- (I) i.  $R \equiv \underbrace{(\lambda x.Ax)}_S B, \quad x \notin FV(A)$   
 ii. as i. with  $R, S$  interchanged
- (II) i.  $S \equiv \lambda x. \underbrace{(\lambda y.A)}_R x, \quad x \notin FV(A)$   
 ii. as i. with  $R, S$  interchanged.

In these four cases contraction of  $R$  leaves  $S$  without residuals. For most  $A, B$  this definition is clear, bearing in mind that the residuals of a  $\beta$ - resp.  $\eta$ -redex should be again  $\beta$ - resp.  $\eta$ -redexes; but it is somewhat surprising in case (I)ii if  $A \equiv \lambda y.A'$  and in case (II)i if  $A \equiv A'y$  ( $y \notin FV(A')$ ). Here (I), (II) refer to (I), (II) in 1.2 above.

Redexes  $R, S$  in the positions (I) or (II) are suggestively called in HINDLEY [77] "too close together".

In the sequel (Lemma 4.9) we will need the following proposition. The proof follows immediately by an inspection of the definitions.

2.2. PROPOSITION. Let  $R \equiv (\lambda x.A)B$  and  $H \equiv \lambda y.Cy$  be a  $\beta$ -redex resp. an  $\eta$ -redex in a term  $M$ . Then:

(i)  $R$  and  $H$  are "too close together"  $\iff$

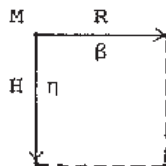

i.e. the elementary diagram  $\mathcal{D}(\{R\}, \{H\})$  is of the type I- or II-absorption.

(ii) if  $R$  and  $H$  are not "too close together", then (a)  $R \cap H = \emptyset$  or (b)  $R \subseteq C$  or (c)  $H \subseteq A$  or (d)  $H \subseteq B$ .  $\square$

2.3. REMARK. Analogous to  $\lambda\beta$ -calculus, if

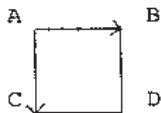

is an elementary diagram, the redexes contracted in  $B \rightarrow D$  are residuals of the redex contracted in  $A \rightarrow C$  and likewise for the bottom side. This could suggest that the Parallel Moves Lemma (I.6.12) for  $\lambda\beta$  carries over to  $\lambda\beta\eta$ . The PM Lemma says that if  $\mathcal{R} = M_0 \rightarrow \dots \rightarrow M_n$  is a finite reduction,  $R \subseteq M_0$  a redex ( $\beta$ - or  $\eta$ - in this case), then the projection  $\{R\}/\mathcal{R}$  consists of contractions of residuals  $R'_i$  of  $R$ :

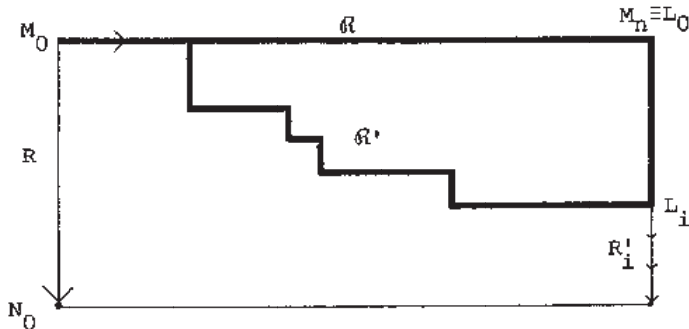



To be more precise, every  $R'_i$  is a residual via the reduction  $M_0 \longrightarrow \dots \longrightarrow L_0 \longrightarrow \dots \longrightarrow L_i$ ; not just via some  $\mathcal{R}' = M_0 \longrightarrow \dots \longrightarrow L_i$  as in the figure. For  $\lambda\beta$  this specification is unnecessary, since there in a diagram descendants and residuals are independent of the reduction path (see Corollary I.10.2.10) not so for  $\lambda\beta\eta$ , as the next example shows.

2.3.1. COUNTEREXAMPLE. *The Parallel Moves Lemma fails in  $\lambda\beta\eta$  for ordinary residuals (as in Def. 2.1).*

A similar counterexample is given independently by R. Hindley in unpublished notes. See p.255.

In the diagram below the labels 0,1 are introduced to be able to indicate which redexes are contracted. R in  $M_0$  is an  $\eta$ -redex  $\lambda y.zIy$ . This  $\eta$ -redex is doubled ( $\lambda_0 y$  and  $\lambda_1 y$ ) and one of those residuals is substituted in the other ( $\lambda_0 y$  in  $\lambda_1 y$ ). Now  $\lambda_0 y$  turns out to be the head- $\lambda$  of a  $\beta$ -redex as well, and  $\lambda_0 y$  is contracted as  $\beta$ -redex. Thereby the other residual  $\lambda_1 y$  is destroyed - that is, it ceases to be a residual of the original  $\eta$ -redex. But precisely that redex  $\lambda_1 y$  is contracted in  $\{R\}/\mathcal{R}$ . So the PM Lemma does not hold for the usual residual concept.

(Note, however, that the final  $\eta$ -redex  $M_5$  is a residual of the original  $\eta$ -redex in  $M_0$  via  $M_0 \longrightarrow M_1 \longrightarrow M'_1 \longrightarrow M'_2 \longrightarrow M'_3 \longrightarrow M_5$ .)

Although in a  $\beta\eta$ -reduction the notion of a residual is not without complications, there is nothing problematic about the descendant relation for *symbols*. We will use this obvious possibility of 'tracing' symbols in a  $\beta\eta$ -reduction to introduce an alternative concept of residual for which the PM Lemma does hold.

2.4. DEFINITION. Let  $\mathcal{R} = M_0 \longrightarrow M_1 \longrightarrow \dots \longrightarrow M_k \longrightarrow \dots$  be a  $\beta\eta$ -reduction,  $R_0$  a redex in  $M_0$  and  $R_k$  a redex in  $M_k$  such that the head- $\lambda$  of  $R_k$  descends from that of  $R_0$ .

Then, regardless whether  $R_0, R_k$  are  $\beta$ - or  $\eta$ -redexes,  $R_k$  is called a  $\lambda$ -residual of  $R_0$  via  $\mathcal{R}$ .

2.4.1. REMARKS AND EXAMPLES.

(i) It is easily checked that in the notation of Def. 2.4:

$R_k$  is residual of  $R_0 \Rightarrow R_k$  is  $\lambda$ -residual of  $R_0$ .

But not the converse; for, consider (on p.256):

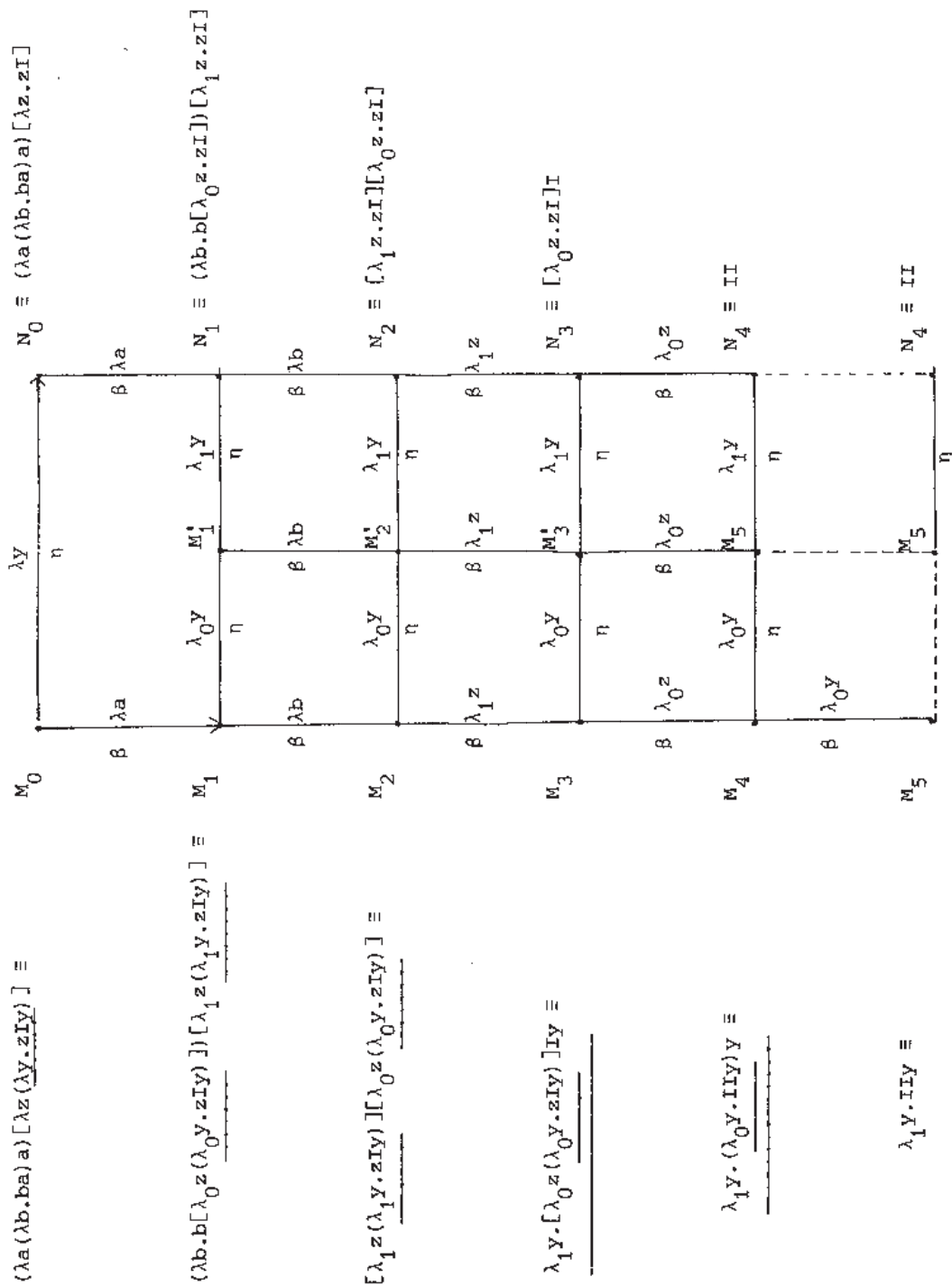

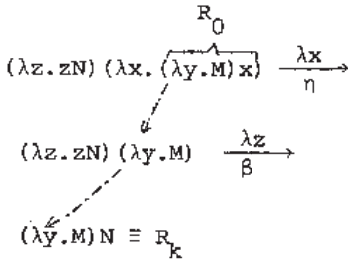

and now  $R_k$  is a  $\lambda$ -residual, but not an ordinary residual, of  $R_0$ . Likewise in the following example:

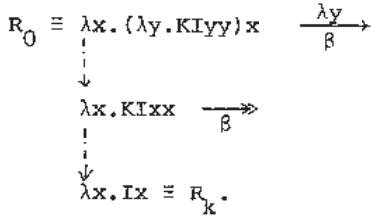

This example shows an undesirable characteristic of the ordinary concept of residuals: by an internal reduction an  $\eta$ -redex can stop being one and a moment later reappear as "the same"  $\eta$ -redex; but the latter is not a residual of the former. It is however a  $\lambda$ -residual of the former.

- (ii) For  $\lambda\beta$ -calculus the two residual notions coincide.
- (iii) Note that in the Counterexample 2.3.1 the final  $\eta$ -redex is a  $\lambda$ -residual of the original one.
- (iv) The theorem of Finite Developments does not hold for  $\lambda$ -residuals:

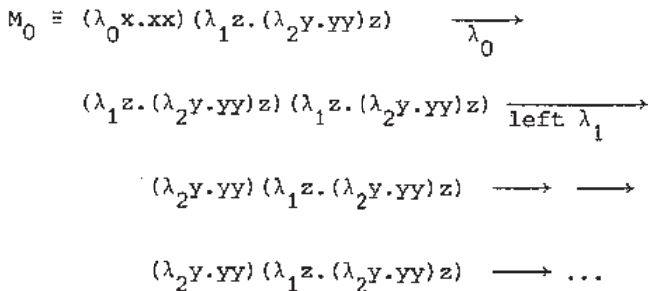

an infinite reduction in which all the contracted redexes are  $\lambda$ -residuals of redexes in  $M_0$ .

On the other hand, FD does hold for ordinary residuals; see BARENDREGT, BERGSTRA, KLOP, VOLKEN [76], Ch.II. The proof there uses the method of decreasing weights as in I.4.

## 3. TRACING IN DIAGRAMS

To keep track of events in a reduction diagram, we will stick labels on the  $\lambda$ 's and follow them by means of these labels. In the  $\beta$ -case this works very well, but in the  $\beta\eta$ -case there is a complication, since in the type II e.d.'s (see 1.2) there is sometimes a "confusion" of  $\lambda$ 's:

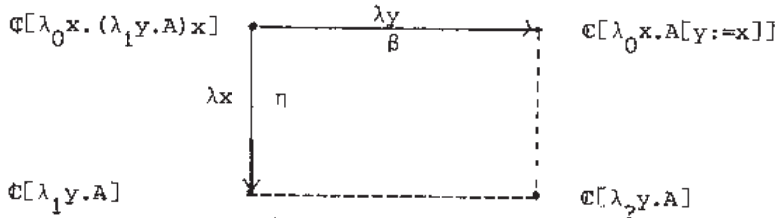

(Note that the two terms on the right are syntactically equal modulo  $\alpha$ -equivalence, renaming of bound variables.)

Now it is not clear whether the label? in  $\mathcal{C}[\lambda_? y. A]$  should be 0 or 1. Therefore we put  $? = \{0,1\}$ . In general:

3.1. DEFINITION. Let us admit as labels for  $\lambda$ 's (not only redex- $\lambda$ 's) in a  $\beta\eta$ -reduction diagram finite sets of natural numbers, denoted by  $\alpha_0, \alpha_1, \dots$

In every e.d. except type II it is clear how to carry along these labels. For a type II e.d. the labels are carried along as indicated in the figure above, where 0,1 are replaced by  $\alpha_0, \alpha_1$  and  $? = \alpha_0 \cup \alpha_1$ .

NOTATION. Instead of  $\lambda_{\{n\}}$  we write  $\lambda_n$ ; instead of  $\lambda_{\{0,1\}}$  we write  $\lambda_{01}$  and for  $\lambda_{\emptyset}$  just  $\lambda$ .

3.2. As we said before, we can visualize reduction steps in a diagram as objects moving to the right or downwards, thereby possibly splitting or becoming trivial (empty). This gives rise to what we will call *propagation paths*, indicated by  $\rightsquigarrow$ , see the figure below. They should be distinguished from the *reduction paths* in the diagram, which are ordinary reduction sequences of terms - except that empty steps may occur in them. Thirdly, we will distinguish in a reduction path the paths which we get by tracing a single symbol, in case a  $\lambda$ . These are  $\lambda$ -paths.

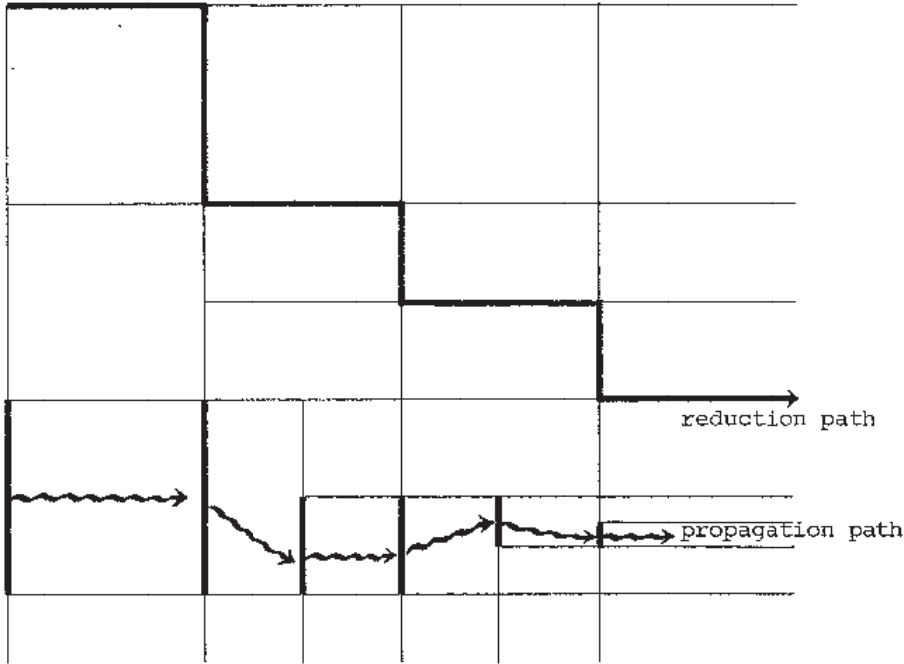

The notion of ' $\lambda$ -path' seems sufficiently clear to make further illustration of it superfluous.

Note that if  $A, B$  are terms on a reduction path and  $\lambda_0$  is in  $B$ , then  $\lambda_0$  can be traced to a unique 'father'  $\lambda$  in  $A$ . Even in the  $\beta\eta$ -case there is no ambiguity. Now note the difference between  $\beta$ -diagrams  $\mathcal{D}_\beta$  and  $\beta\eta$ -diagrams  $\mathcal{D}_{\beta\eta}$ : if  $A, B$  are terms in  $\mathcal{D}_\beta$ ,  $B$  'later' than  $A$  (see next figure) then a  $\lambda_0$  in  $B$  traces back to a unique  $\lambda$  in  $A$ , *regardless of the reduction path between  $A$  and  $B$  which one chooses to trace back*. But in  $\mathcal{D}_{\beta\eta}$  the father in  $A$  of  $\lambda_0$  in  $B$  *depends on the chosen reduction path*. This is caused by the confusion of  $\lambda$ 's which we observed earlier and which caused us to introduce growing labels  $\alpha_i \subseteq \mathbb{N}$ .

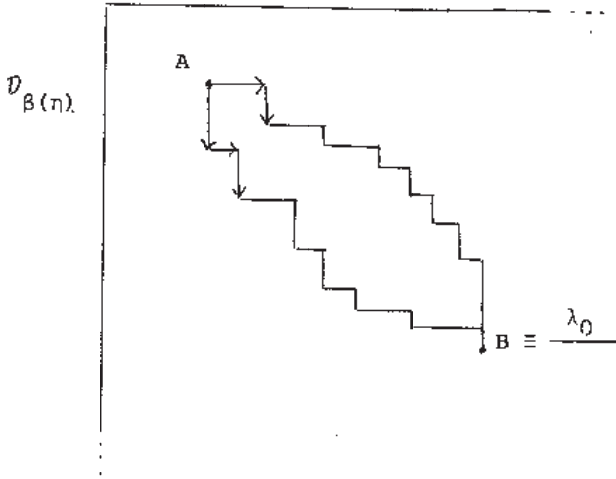

3.3. DEFINITION. Let  $M \xrightarrow{\lambda_\alpha} N$  be a  $\beta$ - or  $\eta$ -reduction step, where  $\lambda_\alpha$  is the head- $\lambda$  of the contracted redex. Par abus de langage,  $\lambda_\alpha$  will be called 'the contracted redex- $\lambda$ ' of this step.

Before formulating the properties of the labels  $\alpha_i$  which make them useful, we will give an example illustrating these properties.

3.4. EXAMPLE.

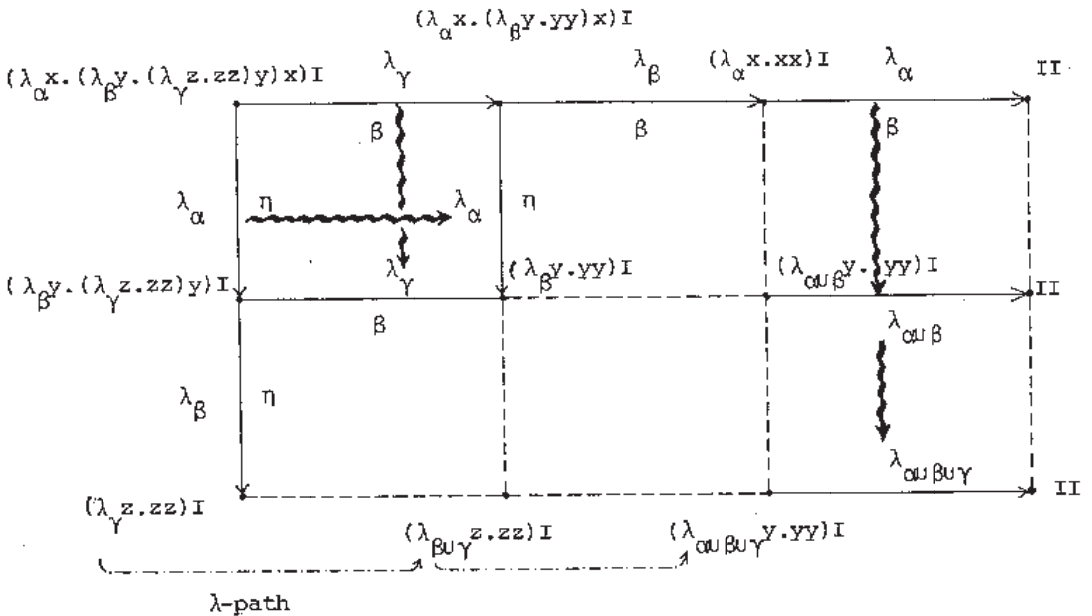

Note that in a propagation path  $\lambda \rightsquigarrow \lambda \rightsquigarrow \dots$  as well as in a  $\lambda$ -path  $\lambda \dashrightarrow \lambda \dashrightarrow \dots$  the labels can increase.

3.5. LEMMA. Let

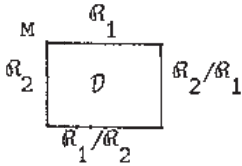

be a completed  $\beta\eta$ -diagram.

Let all the  $\lambda$ 's in  $M$  have a label and carry along these labels throughout  $\mathcal{D}$ . Let  $\text{Ind}(R_1)$  be the union of labels of  $\lambda$ 's contracted in  $R_1$ , and similarly for the reductions  $R_2$ ,  $R_1/R_2$  and  $R_2/R_1$ . Then the following holds:

- (i)  $\text{Ind}(R_1/R_2) \cup \text{Ind}(R_2/R_1) \subseteq \text{Ind}(R_1) \cup \text{Ind}(R_2)$
- (ii) the label of a  $\lambda$  is weakly monotonically increasing along a  $\lambda$ -path in  $\mathcal{D}$ , i.e. if  $\lambda_\alpha \dashrightarrow \lambda_\beta$  then  $\alpha \subseteq \beta$ ,
- (iii) similarly for the label of the contracted  $\lambda$  along a propagation path in  $\mathcal{D}$ , i.e. if  $\lambda_\alpha \rightsquigarrow \lambda_\beta$  then  $\alpha \subseteq \beta$ .

Before giving the actual proof, let us make the following remark.

That the lemma is not entirely trivial is due to the fact that in  $R_1$ ,  $R_2$  labels of  $\lambda$ 's occur which are not  $\subseteq \text{Ind}(R_1) \cup \text{Ind}(R_2)$ . What we have to prove is that those labels do not play a role, as label of a contracted  $\lambda$ , further in the diagram.

PROOF. Let a labeling of all the  $\lambda$ 's in  $M$  be given such that the  $i$ -th occurrence of  $\lambda$  in  $M$  has label  $\alpha_i$ . It is not required that  $\alpha_i \neq \alpha_j$  for  $i \neq j$ ; the  $\alpha_i$  are entirely arbitrary. Without loss of generality we may suppose  $\alpha_i = \{i\}$ ; replacing afterwards  $\{i\}$  by arbitrary  $\alpha_i$ , (i), (ii), (iii) obviously remain valid.

Now we will prove (i), (ii), (iii) simultaneously by induction on a construction of  $\mathcal{D}$ .

Suppose that in our inductive proof a construction stage  $\mathcal{D}'$  of  $\mathcal{D}$  is reached:

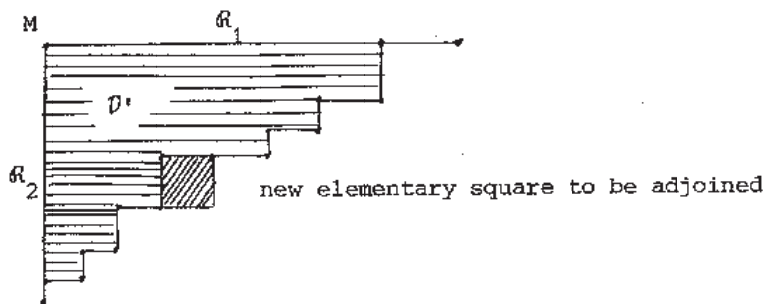

and assume the following induction hypothesis:

- (a) if a contracted  $\lambda$  in  $\mathcal{D}'$  has label  $\alpha$  then  $\alpha \subseteq \text{Ind}(\mathcal{R}_1) \cup \text{Ind}(\mathcal{R}_2)$
- (b) if a  $\lambda$  in  $\mathcal{D}'$  has a *non-singleton* label  $\alpha$ , then  $\alpha \subseteq \text{Ind}(\mathcal{R}_1) \cup \text{Ind}(\mathcal{R}_2)$ .

The induction hypothesis is clearly fulfilled in stage 0 of the construction.

The remainder of the proof consists of checking the e.d.'s plus what happens in them with the labels. Without comment we will only mention the critical cases. Note that the label of a  $\lambda$  in a  $\lambda$ -path can only increase in a trivial step, and that the label of the contracted  $\lambda$  in a propagation path can only increase in the first e.d. below:

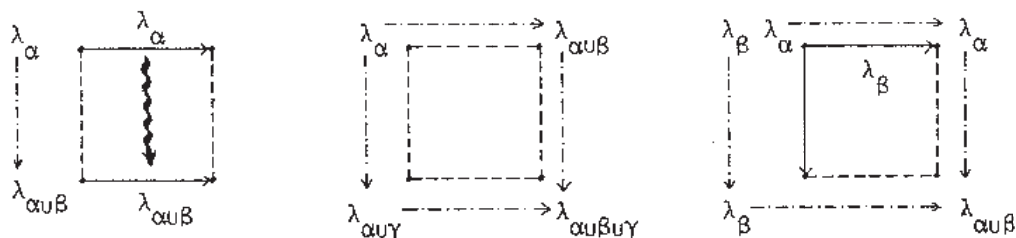

It is only a matter of patience to verify that (a) and (b) again hold for  $\mathcal{D}' + \square$ . We will omit this verification here. If the diagram is completed, then (a) of the ind.hyp. entails (i) of the Lemma. Part (b) of the ind.hyp. serves to prove (a) in the case of adjunction of the first e.d. above.  $\square$

**3.6. COROLLARY.** Let  $R \subseteq M$  be a redex of which no  $\lambda$ -residual is contracted in  $\mathcal{R}_1$  nor in  $\mathcal{R}_2$  (see figure). Let  $S \subseteq N$  be a  $\lambda$ -residual of  $R$ .



Then no  $\lambda$ -residual of  $S$  is contracted in  $\mathcal{R}_1/\mathcal{R}_2$ .

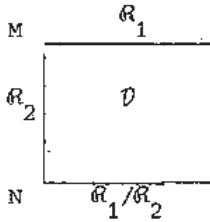

PROOF. Let the  $\lambda$  of  $R$  have label 0, all other  $\lambda$ 's label 1. Then by the hypothesis of the corollary,  $0 \notin \text{Ind}(\mathcal{R}_1) \cup \text{Ind}(\mathcal{R}_2)$ . Hence by (i) of the previous lemma,  $0 \notin \text{Ind}(\mathcal{R}_1/\mathcal{R}_2)$ .  $\square$

3.7. PARALLEL MOVES LEMMA, for  $\lambda\beta\eta$  w.r.t.  $\lambda$ -residuals. Let

$\mathcal{R} = M_0 \rightarrow \dots \rightarrow M_n$  and let  $R$  be a redex in  $M$ . Then in  $\mathcal{D}(\mathcal{R}, \{R\})$  the projection  $\{R\}/\mathcal{R}$  consists of contractions of  $\lambda$ -residuals of  $R$ , via the reduction  $M_0 \rightarrow \dots \rightarrow M_n \xrightarrow{\lambda_{i0}} \dots$

In other words: the  $\lambda$ 's of the redexes contracted in  $\{R\}/\mathcal{R}$  can be traced back via  $M_n$  to the  $\lambda$  of  $R$ .

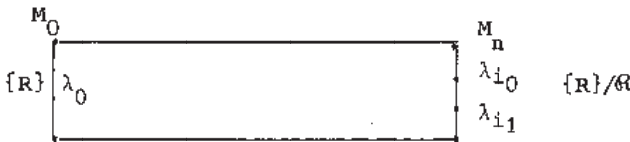

PROOF. The following argument is typical for the notions of diagram construction and tracing of  $\lambda$ 's by means of growing labels.

Label the  $\lambda$  of  $R$  with 0, all other  $\lambda$ 's in  $M_0$  with 1. So the  $\lambda_{ij}$  in  $\{R\}/\mathcal{R}$  have label 0 or 01 by Lemma 3.5.(i). If a  $\lambda_{ij}$  has label 0 we are done, for such  $\lambda_{ij}$  can only be traced back to  $\lambda_0$  by Lemma 3.5.(iii). But if it has label 01, it might be the case that such a  $\lambda$  traces back via  $M_n$  to a  $\lambda_1$  in  $M_0$ , what we don't want.

Let us suppose this is the case (\*). First we note that in  $M_n$  no multiple labels (01) can occur, since in a  $\lambda$ -path the label can only increase after an empty step (see the e.d.'s in the proof of 3.5) and  $\mathcal{R}$  does not contain  $\emptyset$  steps. Hence, if a  $\lambda_{01}$  in  $\{R\}/\mathcal{R}$  traces back via  $M_n$  to a  $\lambda_1$  in  $M_0$ , this trace must be via a  $\lambda_1$  in  $M_n$ . This implies that in  $\{R\}/\mathcal{R}$  a  $\emptyset$ -step must occur, in which this label 1 grows to 01:

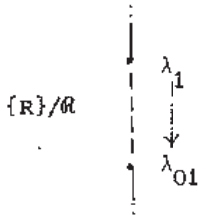

Let us call such a situation a 'vertical 1-adjunction'.

Now consider an arbitrary construction of the diagram  $\mathcal{D}(\{R\}, \mathcal{R})$  and in this construction the first addition of an e.d. in which a vertical 1-adjunction occurs. This e.d. must have one of the two following forms:

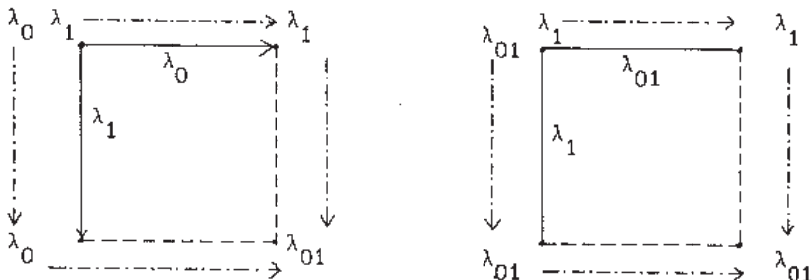

However, in both cases we have a vertical  $\lambda_1$ -contraction, in contradiction with Lemma 3.5.(ii) which states that for every vertical  $\lambda_\alpha$ -contraction we must have  $0 \in \alpha$  (since we started with a vertical  $\lambda_0$ -contraction).

So we have proved that (\*) is not the case, i.e. also the  $\lambda_{01}$  in  $\{R\}/\mathcal{R}$  trace back to  $\lambda_0$  in  $M_0$ .  $\square$

#### 4. STANDARDIZATION OF $\beta\eta$ -REDUCTIONS

As in I.9 for  $\lambda\beta$ , we will employ a marker to help us remember which (residuals of) redexes are not allowed to be contracted in a standard reduction. In fact we need two markers:  $*_\beta$  and  $*_\eta$ , for  $\beta$ - resp.  $\eta$ -redexes.

**4.1. DEFINITION.** Every time when in a reduction a  $\beta$ - or  $\eta$ -redex with head- $\lambda$  (say)  $\lambda_0$  is contracted, we attach to all the  $\beta$ -redex- $\lambda$ 's  $< \lambda_0$  a marker  $*_\beta$  (if not already present) and to all the  $\eta$ -redex- $\lambda$ 's  $< \lambda_0$  a marker  $*_\eta$  (if not already present). Note that it may happen that one  $\lambda$  bears both markers:  $\lambda^{*\beta*\eta}$ . These markers are carried along in a reduction as follows:

- 1) all the residuals of  $(\lambda^{*\beta} x.A)B$  will be marked by  $^*\beta$
- 2) all the residuals of  $\lambda^{*\eta} x.Ax$  ( $x \notin FV(A)$ ) will be marked by  $^*\eta$ .

Now a *standard*  $\beta\eta$ -reduction is a reduction in which no redex is contracted whose head- $\lambda$  is marked.

4.2. REMARK. This definition is equivalent with the definition of *strongly standard*  $\beta\eta$ -reduction in HINDLEY [78].

It turns out to be convenient for the proof below to work with a *stronger notion of standardness*, which is also easier to formulate (with the terminology of markers).

4.3. DEFINITION.

- (i) Every time when a  $\beta$ - or  $\eta$ -redex with head- $\lambda$  (say)  $\lambda_0$  is contracted, we mark *all the redex- $\lambda$ 's* ( $\beta$ - or  $\eta$ -) to the left of  $\lambda_0$  with  $*$ , if not yet marked.
- (ii) These markers are carried along in the reduction as follows. *All the  $\lambda$ 's which descend from a  $\lambda^*$* , will also be marked - regardless whether they are redex- $\lambda$ 's or not.
- (iii) Now a  $\lambda$ -*standard*  $\beta\eta$ -reduction is one in which no redex is contracted whose  $\lambda$  is marked.

4.4. REMARK.

- (i)  $\lambda$ -standard = standard w.r.t.  $\lambda$ -residuals.
- (ii)  $\mathcal{R}$  is a  $\lambda$ -standard  $\beta\eta$ -reduction  $\Rightarrow \mathcal{R}$  is a standard  $\beta\eta$ -reduction.  
Cf. 2.4.1.(i). Here also, the converse does not hold.

4.5. THE STANDARDIZATION PROCEDURE FOR  $\lambda\beta\eta$

First we will extend the relation " $<$ " (to the left of) for  $\lambda$ 's in a term to redexes.

4.5.1. DEFINITION. Let  $M$  be a  $\lambda$ -term and  $R, S$  two redexes in  $M$ . Then

$$R < S \iff \lambda_R < \lambda_S \text{ or } S \not\subseteq R.$$

Here  $\lambda_R, \lambda_S$  are the head- $\lambda$ 's of  $R, S$ .

4.5.2. REMARK. So if  $R, S$  are in position (I) (Def.2.1),  $R \equiv (\lambda x.Ax)B \equiv SB$ , then the  $\beta$ -redex  $R$  is to the left of the  $\eta$ -redex  $S$ .

4.5.3. DEFINITION. Let  $\mathcal{R} = M_0 \longrightarrow M_1 \longrightarrow \dots$  be a (finite or infinite) reduction.

- (i) In  $M_0$  we select a redex, called  $\text{lmc}(\mathcal{R})$ , as follows.  $\text{lmc}(\mathcal{R}) :=$  the leftmost redex in  $M_0$  of which a  $\lambda$ -residual is contracted in  $\mathcal{R}$ .
- (ii) As in I.7 for  $\lambda\beta$ , define

$$p(\mathcal{R}) := \mathcal{R} / \{ \text{lmc}(\mathcal{R}) \}.$$

4.5.4. DEFINITION OF THE STANDARDIZATION PROCEDURE FOR  $\lambda\beta\eta$

Let  $\mathcal{R} = M_0 \longrightarrow M_1 \longrightarrow \dots$  be given. Then the (possibly infinite) reduction  $\mathcal{R}_s$  is obtained as follows:

$$\mathcal{R}_s = M_0 \xrightarrow{\text{lmc}(\mathcal{R})} M'_1 \xrightarrow{\text{lmc}(p\mathcal{R})} M'_2 \xrightarrow{\text{lmc}(p^2\mathcal{R})} \dots$$

Cf. I.9.3; see also the figure there.

Before we prove that  $\mathcal{R}_s$  is  $\lambda$ -standard, hence standard, and that if  $\mathcal{R}$  and  $\mathcal{R}_s$  end in the same term, we will give some examples and state some technical lemmas.

4.6. EXAMPLES. *Example 1* shows why we introduced  $\lambda$ -residuals in the definition of the standardization procedure. For, the straightforward generalization of the method for  $\lambda\beta$ -calculus would have used  $*_{\beta}, *_{\eta}$  (see 4.1), i.e. standardness w.r.t. the usual residual concept, and as  $\text{lmc}(\mathcal{R})$  we would have taken: the leftmost redex in  $M_0$  which has a residual (in the usual sense) contracted in  $\mathcal{R}$ .

But this generalization fails: as this example shows the result of the procedure need not be standard. (This was pointed out to me by Gerd Mitschke.)

As usual, the dotted lines in the reduction diagram below denote empty steps.

$\mathcal{R}$

	$(\lambda x. (\lambda y. yR) (Ix)) X$	$Ix$	$(\lambda x. (\lambda y. yR) x) X$	$(\lambda y. yR) X$	$XR$	$XR'$
$\lambda y$	$\beta$		$\eta$	$\beta$		$\beta$
$(\lambda x. IxR) X$			$(\lambda x. xR) X$	$(\lambda x. xR) X$	$XR$	$XR'$
$\lambda x$	$\beta$		$\beta$	$\beta$		$\beta$
$IXR$			$XR$	$XR$	$XR$	$XR'$
	$\beta$					$\beta$
$XR$			$XR$	$XR$	$XR$	$XR'$
	$\beta$		$\beta$	$\beta$		$\beta$
$XR'$			$XR'$	$XR'$	$XR'$	$XR'$

Example 2 shows how application of the  $\lambda$ -standardization method does produce a  $\lambda$ -standard (and hence standard) reduction for  $\mathcal{R}$ , the same reduction as in Example 1.

In the diagram below, the  $\lambda$ 's of redexes which have a  $\lambda$ -residual contracted in  $\mathcal{R}$  are indicated by †. Similarly for  $p(\mathcal{R}), p^2(\mathcal{R}), \dots$

Note that  $\mathcal{R}$  contains an  $\eta$ -step while  $\mathcal{R}_s$  does not. This is because in the definition of 'lmc' we have built in a preference for  $\beta$ -steps over  $\eta$ -steps: if a  $\lambda$  is a  $\beta$ -redex  $\lambda$  as well as an  $\eta$ -redex  $\lambda$ , the  $\beta$ -redex is to the left of the  $\eta$ -redex (Def. 4.5.1)

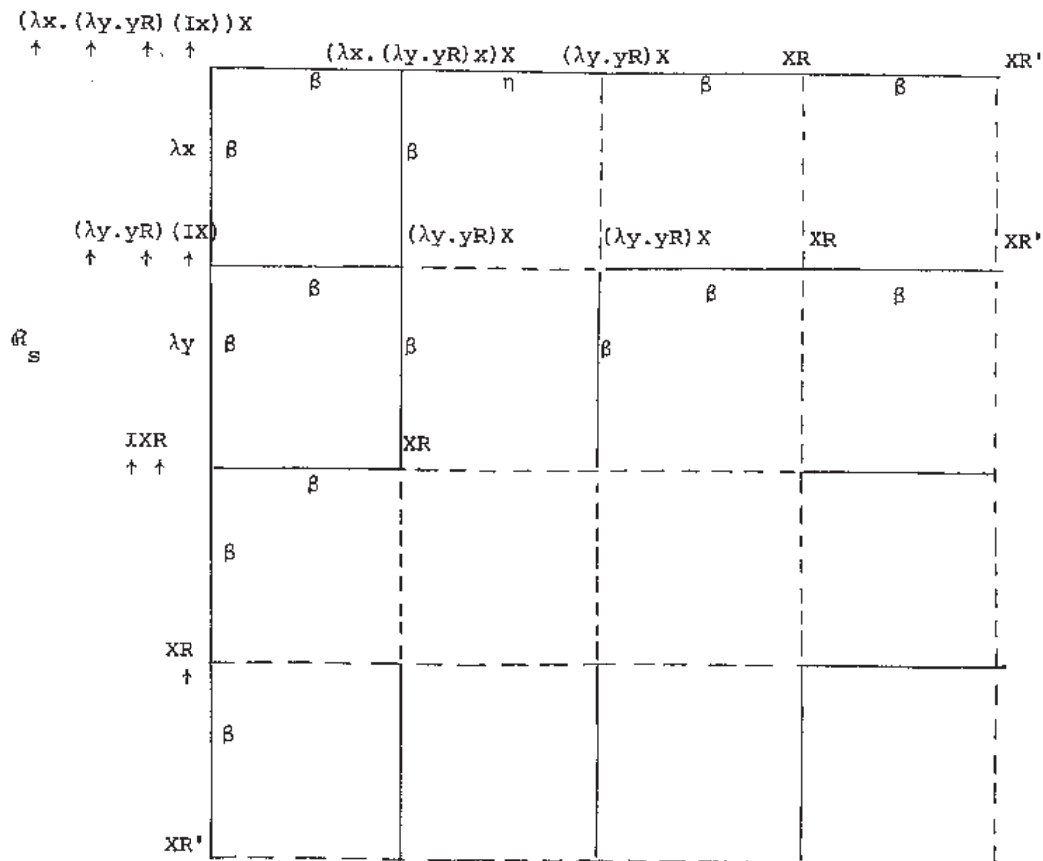

**EXAMPLE 3.** In the reduction diagram below, the upper reduction  $\mathcal{R}$  contains a  $\beta$ -step  $(\lambda y)$ , which is in a remarkable way transformed by the standardization procedure into an  $\eta$ -step  $(\lambda y)$  in  $\mathcal{R}_S$ .

$\lambda x. (\lambda y. KIyy)x$   
 $\uparrow \quad \uparrow \quad \uparrow$

$\lambda y. KIyy$   
 $\uparrow$

$\lambda y. Iy$   
 $\uparrow$

	$\lambda x. KIxx$	$\lambda x. Ix$	$I$
$\eta$	$\beta, \lambda y$	$\beta, K$	$\eta$
$K$	$\beta$	$\lambda y. KIyy$ $\beta, K$	$\lambda y. Iy$ $\eta$
$\eta$	$\eta$	$\lambda y. Iy$ $\eta$	$\eta$
	$I$	$I$	$I$

**EXAMPLE 4.** Here, as in example 2, an  $\eta$ -step in  $\mathcal{A}$  is transformed into a  $\beta$ -step in  $\mathcal{A}_s$ .

$(\lambda z. zN) (\lambda x. (\lambda y. M)x)$   
 $\uparrow \quad \uparrow \quad \uparrow$

$(\lambda x. (\lambda y. M)x)N$   
 $\uparrow \quad \uparrow$

$(\lambda y. M)N$   
 $\uparrow$

	$(\lambda z. zN)$	$(\lambda y. M)$	$(\lambda y. M)N$	$M(N)$
$\beta$	$\eta$	$\beta$	$\beta$	
$\beta$	$\eta$	$(\lambda y. M)N$	$(\lambda y. M)N$	$M(N)$
$\beta$	$\beta$	$\beta$	$\beta$	
$M(N)$				

EXAMPLE 5.

$(\lambda x. \omega(Ix))M$   
 $\uparrow \uparrow \uparrow$

$(\omega = \lambda y. yy)$

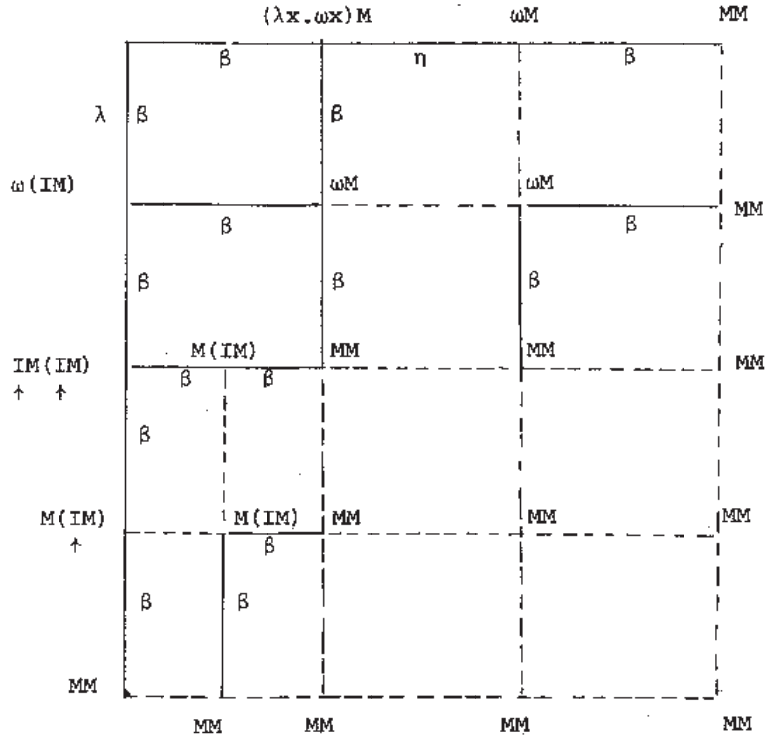

4.6.1. REMARK. Without the trivial steps the diagrams would be much simpler; in example 5 we would have

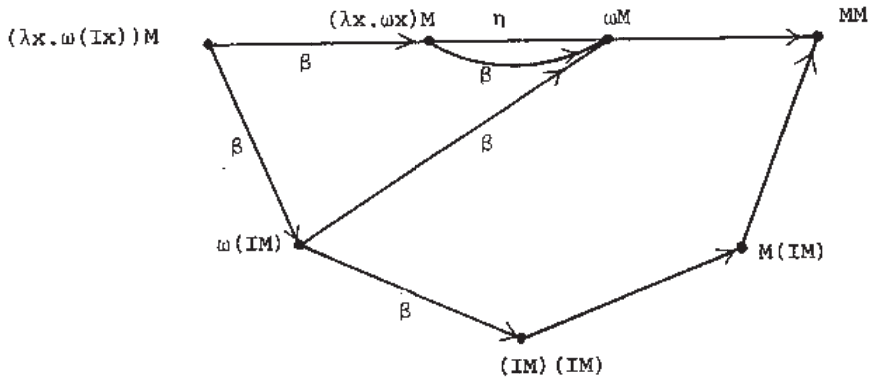

But in this way we loose all intuition for the standardization procedure.



In a standard reduction in  $\lambda\beta$ -calculus the 'action' is literally going from left to right in a term. In a standard  $\beta\eta$ -reduction this is not so; sometimes there is a leftward jump, as in the following examples:

$$\lambda x.(a\lambda y.xy) \xrightarrow[\eta]{} \lambda x.ax \xrightarrow[\eta]{} a$$

or

$$\lambda x.a(Ix) \xrightarrow[\beta]{} \lambda x.ax \xrightarrow[\eta]{} a$$

or

$$\lambda x.(\lambda z.a)xx \xrightarrow[\beta]{} \lambda x.ax \xrightarrow[\eta]{} a.$$

It is clear that such a leftward jump in a  $\beta\eta$ -standard reduction occurs only to contract an  $\eta$ -redex. (We will not prove this fact.) The next lemma states that our standard reduction in  $\text{spe}, \mathcal{R}_s$ , indeed satisfies this requirement. Then we prove, using this property, that  $\mathcal{R}_s$  is  $\lambda$ -standard.

**4.7. LEMMA.** *If in  $\mathcal{R}_s$  a  $\lambda$  is contracted to the left of a  $\lambda^*$ , then this must be an  $\eta$ -contraction. And hence, by the definition of  $\ellmc$  (with its built-in preference for  $\beta$ -reductions if there is choice) it is a contraction of a passive  $\eta$ -redex.*

**PROOF.** Suppose the lemma is false: let  $M'_{n+m+1}$  (see figure) be the first term in  $\mathcal{R}_s$  in which a  $\lambda$  (say  $\lambda_0$ ) as  $\beta$ -redex is going to be contracted with a  $\lambda^*$  (say  $\lambda_1^*$ ) to its right. Let  $M'_n$  be the term in which this  $\lambda_1^*$  got its marker. By  $\lambda$  is meant the  $\lambda$  which is going to be contracted, by  $\lambda^*$  that this  $\lambda$  possibly bears a marker  $*$  (in the situation above this is in fact not possible).

Now it is not hard to see that  $\lambda_0, \lambda_1$  in  $M'_{n+m+1}$  trace back to  $\lambda_0, \lambda_1$  in  $M'_n$  in the same position  $\lambda_0 < \lambda_1$ . (\*). This is so because every  $\lambda$  in  $M'_n, \dots, M'_{n+m}$  such that  $\lambda < \lambda_0, \lambda_1$  is an  $\eta$ -redex- $\lambda$  by our hypothesis.

Moreover, by the same hypothesis,  $\lambda_0$  is in  $M'_n$  already a  $\beta$ -redex- $\lambda$ . Here we use also the following fact:

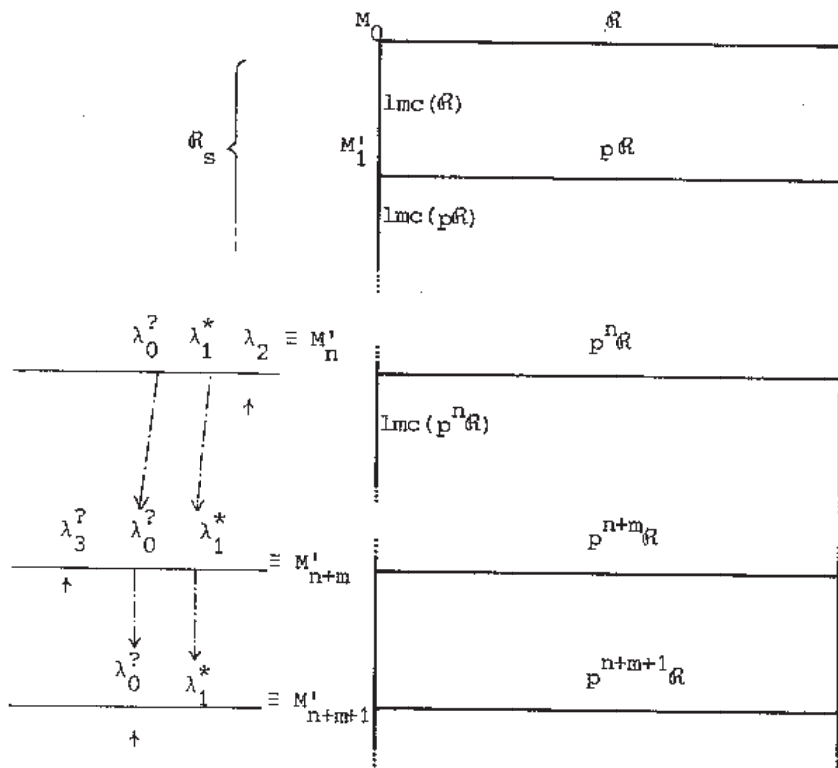

if a  $\lambda$  is not a  $\beta$ -redex- $\lambda$ , then the same is true after an  $\eta$ -reduction.  
 (Another formulation of this fact is:

$\eta$ -reductions do not create new  $\beta$ -redexes w.r.t.  $\lambda$ -residuals.)

Note that this is not true w.r.t. ordinary residuals; cf.:

$$[\lambda x. (\lambda y. M) x] N \xrightarrow{\eta} (\lambda y. M) N,$$

where  $(\lambda y. M) N$  is a newly created  $\beta$ -redex.)

Now  $\lambda_{\uparrow 2}$  in  $M'_n$  is to the right of  $\lambda_1^*$ , because  $\lambda_1$  was marked for the first time in  $M'_n$ . Therefore (by  $(*)$ ) also  $\lambda_{\uparrow 2} > \lambda_0$  in  $M'_n$ . By the definition of  $\text{lmc}$ , this means that  $\lambda_0$  in  $M'_n$  has no contracted  $\lambda$ -residual in  $p^n R$ .

Also  $\lambda_0$  in  $M'_n$  has no contracted  $\lambda$ -residual in the reduction  $M'_n \rightarrow \dots \rightarrow M'_{n+m+1}$ . Here we use that  $\lambda_0$  is not multiplied in this reduction (this could only be done by a  $\beta$ -redex to the left of  $\lambda_0$  and hence of  $\lambda_1^*$ ; but according to the hypothesis such redexes cannot be contracted in

this reduction.)

Hence, by Coroll. 3.6,  $\lambda_0$  in  $M'_{n+m+1}$  has no contracted  $\lambda$ -residual in  $p^{n+m+1}\mathcal{R}$ . But then, contrary to what we supposed, in  $M'_{n+m+1}$ :  $\lambda_0 \neq \text{lmc}(p^{n+m+1}\mathcal{R})$ . Contradiction.  $\square$

It is now easy to prove:

4.8. LEMMA.  $\mathcal{R}_S$  is a  $\lambda$ -standard reduction sequence.

PROOF. Consider the following enlargement of the above figure:

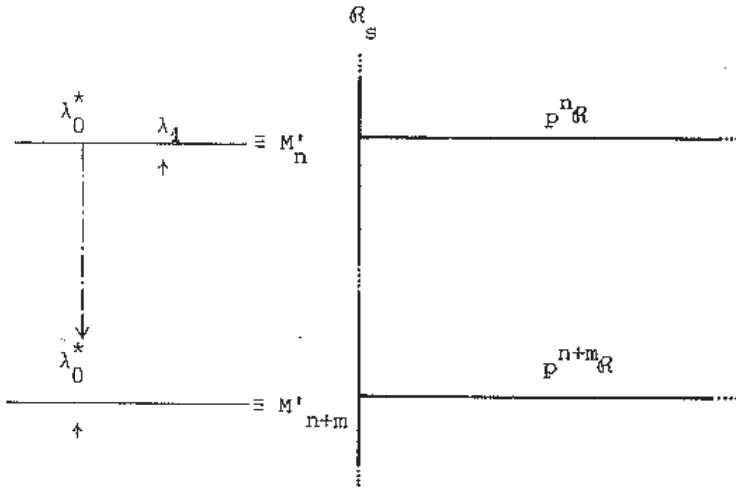

Let us first note as an immediate consequence of the preceding lemma, that no  $\lambda^*$  in  $\mathcal{R}_S$  can be multiplied.

Now suppose that  $\mathcal{R}_S$  is not  $\lambda$ -standard. Then there is a  $\lambda_0$  in  $M'_n$  which gets a  $*$  there for the first time, and descending to a  $\lambda$ -residual in say  $M'_{n+m}$  which is  $\text{lmc}(p^{n+m}\mathcal{R})$ . The (redex whose head- $\lambda$  is)  $\lambda_0$  in  $M'_n$  has no  $\lambda$ -residual contracted in  $p^n \mathcal{R}$ , otherwise the  $\lambda_1$  (displayed there) would not have been  $\text{lmc}(p^n \mathcal{R})$ . And since  $\lambda_0^*$  in  $M'_n$  is not multiplied in the reduction  $M'_n \rightarrow \dots \rightarrow M'_{n+m}$ ,  $\lambda_0^*$  has no  $\lambda$ -residual contracted in that reduction.

Hence, by Corollary 3.6,  $\lambda_0$  in  $M'_{n+m}$  has no  $\lambda$ -residual contracted in  $p^{n+m}\mathcal{R}$ . Contradiction.  $\square$

4.9. LEMMA. Let  $\mathcal{R} = M_0 \rightarrow M_1 \rightarrow \dots$  be an infinite  $\beta\eta$ -reduction sequence and  $H \subseteq M_0$  an  $\eta$ -redex. Then the projection of  $\mathcal{R}$  by  $H$  is again infinite.

PROOF. Suppose not. Then every step after say  $M_n$  has an empty projection in the following figure, in particular every  $\beta$ -step after  $M_n$ .

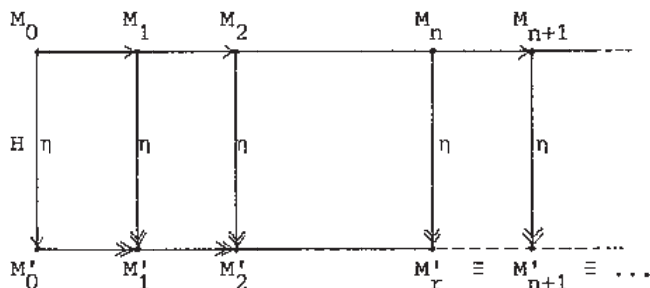

We will now see how such a  $\beta$ -step, which has an empty projection for some projecting  $\eta$ -reduction, looks like; and then conclude that it is impossible for an infinite reduction sequence, in casu  $M_n \rightarrow M_{n+1} \rightarrow \dots$ , to contain next to  $\eta$ -steps only  $\beta$ -steps of that kind.

So let the projection of  $N_0 \xrightarrow{\beta} N'_0$  by the  $\eta$ -reduction  $N_0 \xrightarrow{\eta} N_m$  be empty, as in the next figure. Note that the  $\beta$ -step does not split in its propagation, until it vanishes (becomes  $\emptyset$ ) after some step say  $N_k \xrightarrow{\eta} N_{k+1}$ .

Write  $R_i \equiv (\lambda x.A_i)B_i$  ( $0 \leq i \leq k$ ). From Proposition 2.2 it follows immediately that the  $\eta$ -reduction

$$C_0[(\lambda x.A_0)B_0] \xrightarrow{\eta} C_k[(\lambda x.A_k)B_k]$$

is 'separable' as follows:

$$\begin{aligned} & (a,b) C_0[ ] \xrightarrow{\eta} C_k[ ] \\ (*) \quad & (c) A_0 \xrightarrow{\eta} A_k \\ & (d) B_0 \xrightarrow{\eta} B_k \end{aligned}$$

corresponding to (a), (b), (c), (d) in Prop. 2.2(ii).

(Remark ad (a): in fact  $\eta$ -reduction is not defined for contexts  $C[ ]$ ; but considering a context as a term in which some special free variable  $\square$  may occur once, it is clear what  $\eta$ -reduction of contexts is. E.g.  $\lambda x.y\square zx$  is

a context  $\eta$ -redex.)

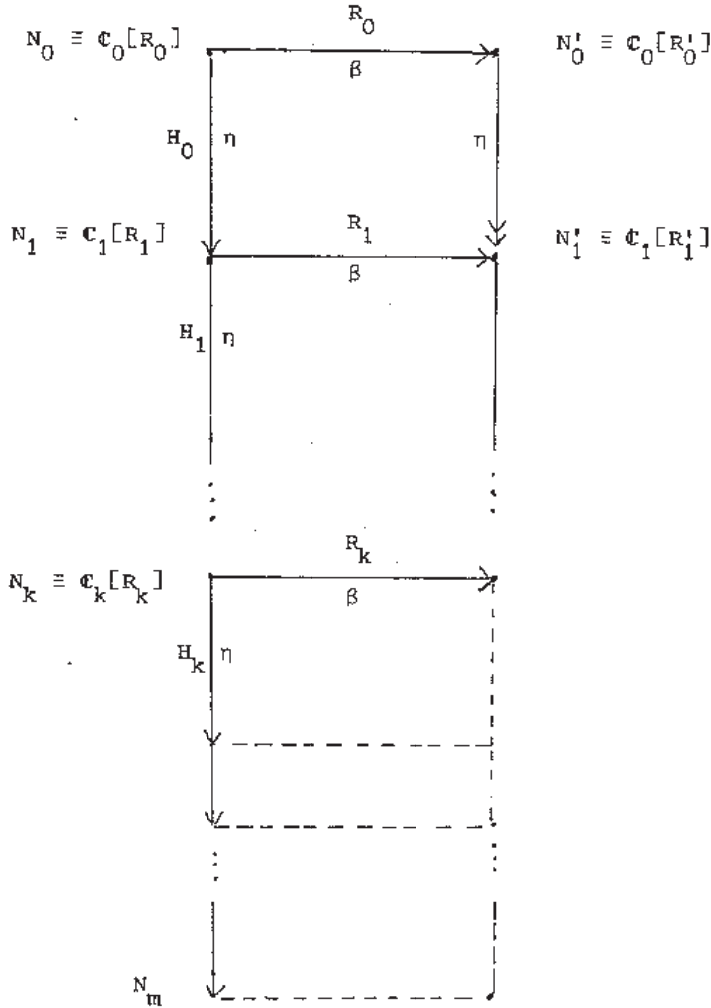

So  $R_0 \xrightarrow{\eta} R_k$ , and the  $\beta$ -redex  $R_k$  and the  $\eta$ -redex  $H_k$  are "too close together". Now there are two cases:  $R_k$  and  $H_k$  I-absorb or II-absorb each other.

CASE (i).  $R_k$  is II-absorbed by  $H_k$  (see 1.2).

Then  $N_k \equiv C_k[R_k] \equiv C_k[(\lambda x.A_k)B_k] \equiv C'_k[\lambda y.(\lambda x.A_k)y] \equiv C'_k[H_k]$ , i.e.

$H_k \equiv \lambda y.R_k$  and  $B_k \equiv y$  and  $y \notin FV(A_k)$ . So by (\*),

$$R_0 \equiv (\lambda x.A_0) \underset{\sim}{y}$$

where we have used the notation  $\underset{\sim}{M}$  for an  $\eta$ -expansion of  $M$ . (I.e.  $\underset{\sim}{M} \xrightarrow{\eta} M$ )

CASE (ii).  $R_k$  is I-absorbed by  $H_k$ .

Then  $N_k \equiv C_k[R_k] \equiv C_k[(\lambda x.A_k)B_k] \equiv C_k[(\lambda x.A'_k)x]B_k$  where  $x \notin FV(A'_k)$ ,

$H_k \equiv \lambda x.A'_k x$ .

So  $A_0 \xrightarrow{\Pi} A'_k x$ , hence  $A_0 \equiv A'_k x$ .

So

$$R_0 \equiv (\lambda x.A'_k x)B_0, \quad x \notin FV(A'_k)$$

Now we have proved that the *infinite* reduction  $M_n \longrightarrow M_{n+1} \longrightarrow \dots$  contains only

- (a)  $\eta$ -steps
- (b)  $\beta$ -steps of type (i)
- (c)  $\beta$ -steps of type (ii).

However, this is impossible: such a reduction cannot be infinite. For let  $m(M)$  be the number of *multiplying*  $\lambda$ 's in  $M$  (not only redex- $\lambda$ 's) where  $\lambda$  in  $\lambda x.A$  is called multiplying iff  $x$  occurs more than once as a free variable in  $A$ . Now type (a) and (c) steps diminish the length  $\ell(M)$  of a term  $M$ , while keeping  $m(M)$  constant, and type (b) steps may increase  $\ell(M)$  but only at the cost of diminishing  $m(M)$ . Hence the ordinal number  $\langle m(M), \ell(M) \rangle = \omega \cdot m(M) + \ell(M)$  decreases in a strictly monotonic way along the reduction  $M_n \longrightarrow M_{n+1} \longrightarrow \dots$  Contradiction.  $\square$

4.10. PROPOSITION.

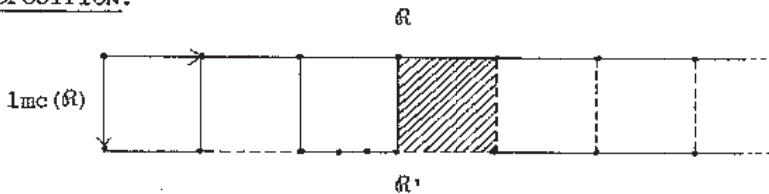

In  $\mathcal{D}(R, \{lmc(R)\})$  the reduction step  $lmc(R)$  propagates to the right, without splitting, until it vanishes (in the indicated square) by 'coincidence' or 'I- or II-absorption' (not erasure).

PROOF. Let  $\lambda_0$  be the head- $\lambda$  of  $lmc(R)$ . Using the same kind of argument as in the proof that  $R_s$  is  $\lambda$ -standard, one shows easily that if somewhere in  $R$  a  $\lambda$  is contracted to the left of (a descendant of)  $\lambda_0$ , then this  $\lambda$  must be an  $\eta$ -redex- $\lambda(*)$ , in fact even a passive  $\eta$ -redex.

From this it follows directly that  $lmc(R)$  does not split and that  $\lambda_0$

is not multiplied in  $\mathcal{R}$ .

From this last fact it is clear that if  $\ell_{mc}(\mathcal{R})$  propagates until the (unique) step in  $\mathcal{R}$  in which  $\lambda_0$  is contracted, then the indicated square must be of one of the following forms:

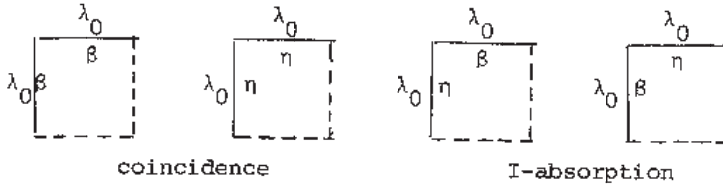

Otherwise the  $\ell_{mc}(\mathcal{R})$  contraction had already vanished before it reached the  $\lambda_0$ -contraction in  $\mathcal{R}$ ; and this can only have happened by II-absorption (not erasure, by (\*).)  $\square$

4.11. PROPOSITION. Let  $\mathcal{R}$ ,  $\lambda_0$  be as in the preceding proposition. Let the step in  $\mathcal{R}$  in which  $\lambda_0$  is contracted, be a  $\beta$ -step. Then  $\ell_{mc}(\mathcal{R})$  is a  $\beta$ -redex (and  $\{\ell_{mc}(\mathcal{R})\}$  a  $\beta$ -step.)

PROOF. (Note that the analogue for  $\eta$  does not hold; see  $p\mathcal{R}$  and  $\ell_{mc}(p\mathcal{R})$  in Example 4.6.4.) Suppose the proposition is false. Then  $\ell_{mc}(\mathcal{R})$  is a passive  $\eta$ -redex. But since to the left of  $\lambda_0$  in  $\mathcal{R}$  only  $\eta$ -reductions take place (see proof of preceding proposition), this passive  $\eta$ -redex cannot be activated, in contradiction with the fact that  $\lambda_0$  in  $\mathcal{R}$  was a  $\beta$ -redex  $\lambda$ .  $\square$

Finally we can combine all these lemmas and propositions:

4.12. THEOREM.  $\mathcal{R}_s$  is a  $\lambda$ -standard (hence standard) reduction sequence for  $\mathcal{R}$ .

PROOF.

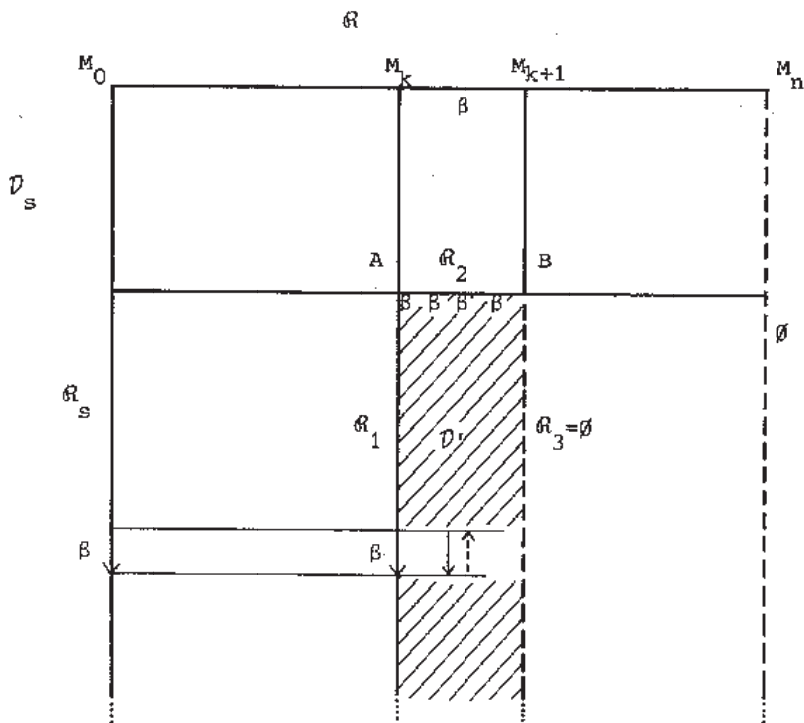

In 4.8 it is proved that  $R_s$  is  $\lambda$ -standard. Proposition 4.10 states that the right side of  $D_s$  is  $\emptyset$ .

Now suppose, for a proof by contradiction, that  $R_s$  is infinite. Then there is a  $k$  such that  $R_s/M_0 \rightarrow \dots \rightarrow M_k$  is infinite and  $R_s/M_0 \rightarrow \dots \rightarrow M_{k+1}$  is finite (i.e. contains after some  $B$  only  $\emptyset$ -steps.)

Let  $D'$  be the subdiagram as in the figure above.

From Lemma 4.9 we know that the "critical" step  $M_k \rightarrow M_{k+1}$  cannot be an  $\eta$ -step (otherwise  $R_s/M_0 \rightarrow \dots \rightarrow M_{k+1}$  was still infinite.) Hence  $R_2$  is a  $\beta$ -reduction, since  $\beta$ -steps propagate as  $\beta$ -steps or  $\emptyset$ -steps. (In fact  $R_2$  is a complete  $\beta$ -development, as is proved in Propositions 5.1 and 5.3(i).)

Now let us look at the "critical" subdiagram  $D'$ . By Prop. 4.11 all the non-empty steps in  $R_1$  and  $\beta$ -steps.

By exactly the same argument as in I.9.6, using the Hyland-Wadsworth labels (I.3.7) and SN for labeled reduction (I.8), it is clear that  $R_1$  must be finite. Contradiction, hence  $R_s$  is finite.



It remains to prove that the lower side of  $\mathcal{D}_s$ , i.e.  $\mathcal{R}/\mathcal{R}_s$ , is empty. This is trivial, for if not, then  $\mathcal{R}_s$  would have continued.

Hence  $\mathcal{R}$  and  $\mathcal{R}_s$  end in the same term  $M_n$ .  $\square$

4.12.1. REMARK. Using the fact that  $\mathcal{R}_2$  is a  $\beta$ -development, once can replace the use of SN for HW-labeled terms by the use of FD for  $\lambda\beta$ .

4.13. REMARK. There are two well-known technical lemmas concerning the relation between  $\beta$ - and  $\eta$ -reductions:

4.13.1. LEMMA. (Postponement of  $\eta$ -reductions)

If  $M \xrightarrow{\beta\eta} N$  then  $\exists L \ M \xrightarrow{\beta} L \xrightarrow{\eta} N$ .

4.13.2. LEMMA.  $M$  has a  $\beta\eta$ -normal form  $\iff M$  has a  $\beta$ -normal form.

It is interesting to note that these lemmas (and in fact, a strengthened version of the first) follow easily using the method of the preceding proof.

PROOF of 4.13.1. Note that Prop. 4.10 remains valid when instead of  $\mathcal{L}mc(\mathcal{R})$  we take  $\mathcal{L}mc_\beta(\mathcal{R})$ , that is: the leftmost  $\beta$ -redex in  $M_0$  having a  $\lambda$ -residual contracted in  $\mathcal{R}$ .

Now define (instead of  $\mathcal{R}_s$ ) the reduction  $\mathcal{R}_{\beta,s}$  by replacing in the definition of  $\mathcal{R}_s$ ,  $\mathcal{L}mc$  by  $\mathcal{L}mc_\beta$ .

Checking the proofs above, we see that also  $\mathcal{R}_{\beta,s}$  is finite, in exactly the same way as for  $\mathcal{R}_s$ .

After  $\mathcal{R}_{\beta,s}$  has stopped (that is, after we have 'exhausted' the  $\mathcal{L}mc_\beta$ -steps) the following situation has arisen:

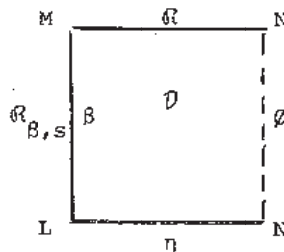

(For, if  $L \xrightarrow{\eta} N$  was not yet an  $\eta$ -reduction,  $\mathcal{R}_{\beta,s}$  would have continued.)

This proves lemma 4.13.1. Now it can be easily checked that something more is proved: all the  $\eta$ -reductions in  $L \xrightarrow{\eta} N$  are passive (an  $\eta$ -reduction

$A \xrightarrow[\eta]{\lambda x.Cx} B$  is passive when  $\lambda x.Cx$  is a passive subterm of  $A$ , i.e. not occurring in  $((\lambda x.Cx)D)$  for some  $D$ .)

For if not,  $\mathcal{R}_{\beta, \eta}$  would have gone further due to its definition and the definition of  $\lambda$ -residual.  $\square$

PROOF of 4.13.2.  $\Leftarrow$  is almost trivial.

$\Rightarrow$ : By Lemma 4.13.1 the  $\eta$ -steps in  $\mathcal{R}$  can be postponed, so we have a reduction  $M \xrightarrow[\beta]{\xrightarrow[\eta]} L \xrightarrow[\eta]{\xrightarrow[\beta]} N$ . Now  $L$  has a  $\beta$ -normal form; for suppose not, then there is an infinite  $\beta$ -reduction  $\mathcal{R}' = L \rightarrow L' \rightarrow L'' \rightarrow \dots$ . So by Lemma 4.9 the projection  $\mathcal{R}'' = \mathcal{R}'/L \xrightarrow[\eta]{\xrightarrow[\beta]} N$  must be infinite:

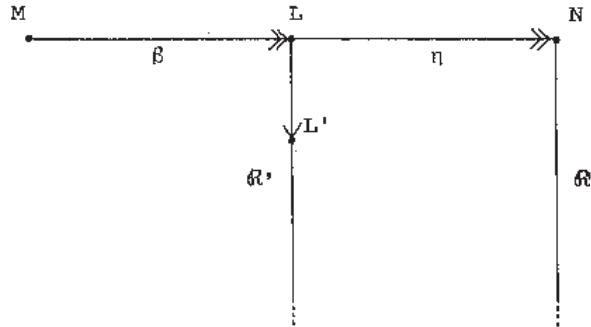

contradicting the fact that  $N$  is a  $\beta\eta$ -normal form.  $\square$

## 5. THE NORMALIZATION THEOREM FOR $\lambda\beta\eta$ -CALCULUS

In this section we will generalize the Normalization Theorem (I.11.2) and the Quasi-normalization Theorem (I.11.6) (in other words: "(eventually) leftmost reductions are normalizing") from  $\lambda\beta$  to  $\lambda\beta\eta$ .

In  $\lambda\beta$  the adjectives 'normal' and 'leftmost' for redexes and reductions were used as synonyms. In  $\lambda\beta\eta$  the leftmost redex- $\lambda$  may belong to two redexes, e.g. in the term  $(\lambda x.ax)b$ ; in such a case Definition 4.5.1 says that the  $\beta$ -redex is the leftmost redex.

### DEFINITION.

- (i) Let  $R \subseteq M$  be a  $\beta$ - or  $\eta$ -redex such that  $R$ 's head- $\lambda$  is the leftmost redex- $\lambda$ . Then  $R$  is called a *normal* redex of  $M$ .

(ii) A *normal* reduction is a reduction in which only normal redexes are contracted. Likewise for the leftmost reduction.

So e.g. the term  $M \equiv (\lambda x.ax)b$  has two normal redexes,  $\lambda x.ax$  and  $M$ . Note that there is now no *unique* normal reduction, though the difference between two coinital normal reductions is inessential. The leftmost reduction is unique; it is that normal reduction having the most  $\beta$ -steps in it.

In  $\lambda\beta$  there is only one standard reduction from a given term  $M$  to its normal form, namely the leftmost (or: normal) reduction. This is no longer true in the  $\lambda\beta\eta$ -calculus. There a  $\lambda$ -standard reduction ending in a  $\beta\eta$ -normal form may by-pass the normal redex(es):

EXAMPLE 1. Let  $\omega \equiv \lambda y.yy$ ,

$$\mathcal{R}_1 = \lambda x.I\omega x \xrightarrow{\beta} \lambda x.\omega x \xrightarrow{\omega} \lambda x.xx.$$

$$\mathcal{R}_2 = \lambda x.I\omega x \xrightarrow{\eta} I\omega \xrightarrow{\beta} \omega.$$

EXAMPLE 2.

$$\mathcal{R}_1 = \lambda x.\omega(Ix) \xrightarrow{\beta} \lambda x.\omega x \xrightarrow{\eta} \omega.$$

$$\mathcal{R}_2 = \lambda x.\omega(Ix) \xrightarrow{\beta} \lambda x.Ix(Ix) \xrightarrow{\beta} \lambda x.x(Ix) \xrightarrow{\beta} \lambda x.xx.$$

In all three cases, both  $\mathcal{R}_1$  and  $\mathcal{R}_2$  are  $\lambda$ -standard while  $\mathcal{R}_2$  is moreover a leftmost reduction.

We will now proceed to the Normalization theorem for  $\lambda\beta\eta$ -calculus. As observed in the preceding remark, the proof of I.11.2 does not carry over to  $\lambda\beta\eta$ , since  $\lambda$ -standard reductions may by-pass the normal redex(es) and still reach a  $\beta\eta$ -normal form.

We have tried to construct a proof as follows: consider an arbitrary  $\lambda$ -standard reduction to the  $\beta\eta$ -normal form, and try to amend this into a normal reduction - but this seemed too messy. Therefore we will follow another proof strategy, in which no use is made of the  $\lambda$ -standardization theorem.

Since the proof involves some technical lemmas and a lot of details, we will begin by exhibiting the dependence of the elements of the proof in the following figure.

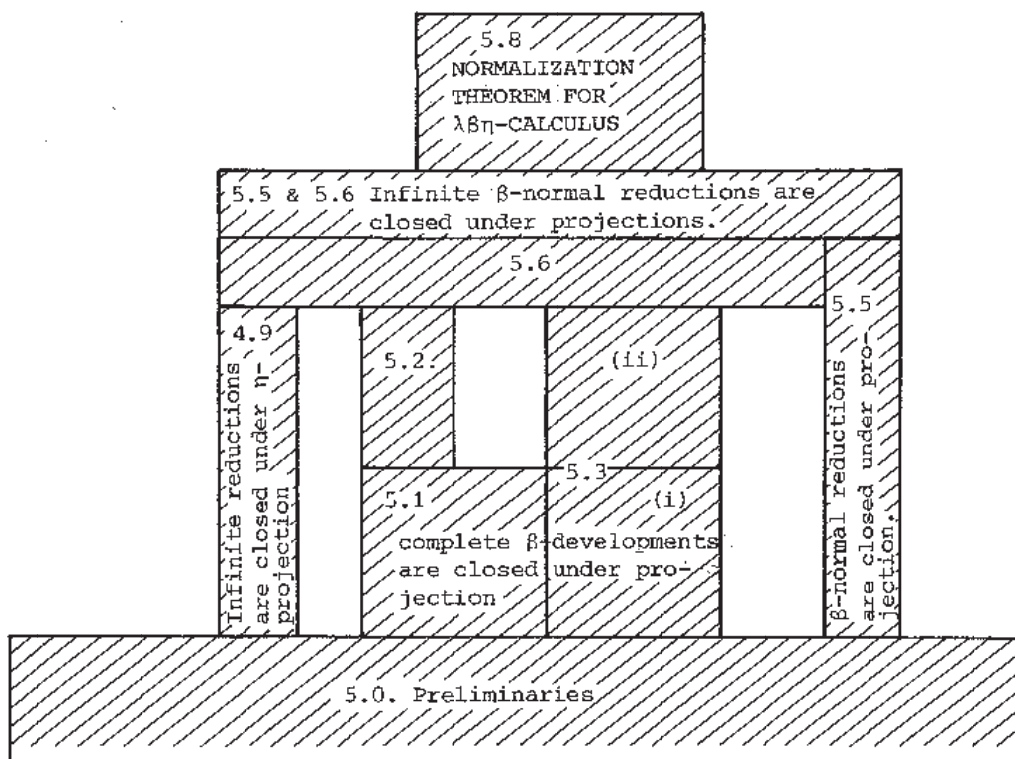

Here the following terminology is used. If  $A$  and  $B$  are two classes of reductions,  $B$  containing only finite reductions, we will say:  $A$  is closed under  $B$ -projections iff for all  $R, R'$ :

$$R \in A, R' \in B, R \text{ and } R' \text{ cointial} \Rightarrow R/R' \in A.$$

E.g. if  $A$  is the class of complete  $\beta$ -developments,  $B$  the class of all finite  $\eta$ -reductions, we will say for short: "complete  $\beta$ -developments are closed under  $\eta$ -projections." When  $B$  is the class of all finite  $\beta\eta$ -reductions, we will just say that "complete  $\beta$ -developments are closed under projections".

## 5.0. PRELIMINARIES

5.0.1. Let  $M$  be a  $\lambda$ -term and  $\mathcal{R}$  a set of  $\beta$ -redexes in  $M$ . As is well-known, all complete  $\beta$ -developments "relative to  $\mathcal{R}$ " end in the same result (FD!). Instead of  $\mathcal{R}$  we will employ a different but equivalent terminology, see also BARENDREGT e.a. [76] Ch.II; instead of the pair  $(M, \mathcal{R})$  we take  $M$  plus an underlining of every  $\lambda$  in  $M$  which is the  $\lambda$  of a redex in  $\mathcal{R}$ ; example:

$$[\underline{\lambda}z.z((\underline{\lambda}x.y\lambda a.a)z)]p.$$

Such an enriched  $M$  will be written as  $(M, \underline{\nu})$ ; sometimes we will identify  $M$  and  $(M, \underline{\nu})$  if it is clear what  $\underline{\nu}$  is meant.  $\underline{\nu}$  can be seen as a set of  $\beta$ -redex- $\lambda$ 's in  $M$ .

Reduction relative to  $\mathcal{R}$  is now called *underlined  $\beta$ -reduction*, or  $\underline{\beta}$ -reduction:

$$(M, \underline{\nu}) \xrightarrow{\underline{\beta}} (M', \underline{\nu}').$$

NOTATION. if  $\underline{\nu}, \underline{\nu}'$  are underlinings of  $M$ , such that  $\underline{\nu} \supseteq \underline{\nu}'$ , we write

$$(M, \underline{\nu}) \supseteq (M, \underline{\nu}').$$

5.0.2. DEFINITION. By (FD), we can define a norm  $\|(M, \underline{\nu})\|$  as the length (i.e. number of steps) of the longest  $\underline{\beta}$ -reduction  $\mathcal{R}$  starting from  $(M, \underline{\nu})$ .

Minimal underlining corresponding to a complete  $\beta$ -development  $\mathcal{R}$

A complete  $\beta$ -development  $\mathcal{R}$  does not determine uniquely a corresponding underlining, since we work in  $\lambda K$ -calculus. But  $\mathcal{R} = M \longrightarrow M' \longrightarrow \dots$  does determine uniquely a *minimal* underlining  $\underline{\nu}_{\min}$ , corresponding to it; namely, the set of all  $\lambda$ 's of  $\beta$ -redexes in  $M$  of which a residual is contracted in  $\mathcal{R}$ .

5.0.3. DEFINITION. Now we define for a complete  $\beta$ -development  $\mathcal{R} = M \longrightarrow M' \longrightarrow \dots$ :

$$\|\mathcal{R}\| = \|(M, \underline{\nu}_{\min})\|.$$

In the sequel we will need the following obvious facts:

5.0.4. PROPOSITION.

(i) If  $(M, v) \xrightarrow{\beta} (M', v')$ , then  $\|(M, v)\| > \|(M', v')\|$ .

(ii) If  $(M, v) \supseteq (M', v')$ , then  $\|(M, v)\| \geq \|(M', v')\|$ .  $\square$

5.0.5.  $\beta\eta$ -terms and their reductions. We borrow a method from BARENDREGT e.a. [76] Ch.II: Introduce two formal symbols  $-$  and  $\sim$ , to be placed under the  $\lambda$  of a  $\beta$ -redex resp. of an  $\eta$ -redex:

$$(\underline{\lambda}x.A)B \quad \text{resp.} \quad \underline{\lambda}x.Cx.$$

RESTRICTION: coincidence of  $-$ ,  $\sim$  is not allowed, so  $(\underline{\lambda}x.Ax)B$  is not a well-formed term in our system.

The symbols  $-$ ,  $\sim$  are introduced to formalize the usual concept of  $\beta\eta$ -residual. Reduction for such  $\beta\eta$ -terms is defined as follows:

- (1) only underlined redexes, i.e.  $(\underline{\lambda}x.A)B$  or  $\underline{\lambda}x.Ax$ , may be contracted,
- (2) all residuals (in the usual sense) of  $(\underline{\lambda}x.A)B$  begin again with  $\underline{\lambda}$ ; similarly for  $\underline{\lambda}x.Ax$ . Residuals of non-underlined terms are again non-underlined.

EXAMPLE.

$$(\underline{\lambda}x.(\underline{\lambda}y.Ay)x)B \xrightarrow{\beta} (\underline{\lambda}y.Ay)B$$

$$" \xrightarrow{\eta} (\underline{\lambda}x.Ax)B$$

$$(\underline{\lambda}x.(\underline{\lambda}y.Ay)x)B \xrightarrow{\eta} (\underline{\lambda}y.Ay)B$$

$$" \xrightarrow{\beta} (\underline{\lambda}x.Ax)B$$

Now it is a routine matter to verify that the construction of diagrams immediately extends to the present case. (This is verified in BARENDREGT e.a. [76] Ch.II, however without  $\beta$ -steps.) Here it is essential that  $\frac{\lambda}{\sim}$  cannot occur. For otherwise we are in trouble:

$$\begin{array}{ccc}
 (\lambda x. (\lambda y. B y) x) C & \xrightarrow[\lambda y]{\beta} & (\lambda x. B x) C \\
 \eta \downarrow \lambda y & & \vdots \\
 (\lambda x. B x) C & \text{-----} & ?
 \end{array}$$

and now it is not clear whether ? should begin with  $\lambda$ ,  $\underline{\lambda}$ ,  $\tilde{\lambda}$ . (Remark: it is possible to find a remedy such that  $\tilde{\lambda}$  is allowed while we retain the "weak CR-property" (i.e. CR for the elementary diagrams) and even (FD) - but at the cost of some complications.)

5.1. PROPOSITION. Complete  $\beta$ -developments are closed under  $\beta$ -projections.

PROOF. Let  $\mathcal{R} = M_0 \rightarrow M_1 \rightarrow \dots \rightarrow M_n$  be a complete  $\beta$ -development and  $R \subseteq M_0$  a  $\beta$ -redex. We must prove that  $\mathcal{R}' = \mathcal{R}/\{R\}$  is again a complete  $\beta$ -development.

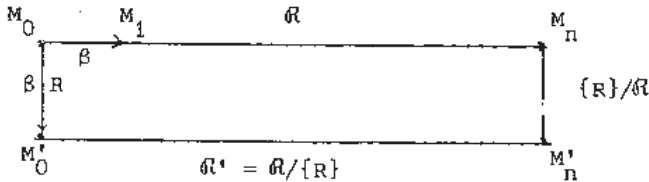

Take the  $u_{\min}$  corresponding with  $\mathcal{R}$  and label the  $\lambda$ 's  $\in u_{\min}$  with 0.

By the usual argument (tracing of labels in  $\beta$ -diagrams) we see that every step in  $\mathcal{R}'$  is also a  $\lambda_0$ -step; moreover all  $\lambda_0$  in  $M'_n$  have disappeared since  $M_n$  contains no  $\lambda_0$ .

Hence  $\mathcal{R}'$  is a complete  $\beta$ -development, namely of the set of  $\beta$ -redexes in  $M'_0$  with  $\lambda_0$  as head- $\lambda$ .  $\square$

5.2. PROPOSITION. Let, as in the above proof,  $\mathcal{R} = M_0 \rightarrow M_1 \rightarrow \dots \rightarrow M_n$  be a complete  $\beta$ -development,  $R \subseteq M_0$  be a  $\beta$ -redex and  $\mathcal{R}' = \mathcal{R}/\{R\}$ . Suppose moreover that

- (i)  $R$  is the leftmost  $\beta$ -redex, and
- (ii)  $\{R\}/\mathcal{R} = \emptyset$ .

Then:  $\|\mathcal{R}\| > \|\mathcal{R}'\|$ .

PROOF. Let  $u_{\min}$  be as above. Since  $R$  is the leftmost  $\beta$ -redex, it is clear that

$$\{R\}/\mathcal{R} = \emptyset \iff \text{the head-}\lambda \text{ of } R \text{ is } \in u_{\min}.$$

Hence the head- $\lambda$  of  $R$  is underlined. Hence we have

$$(M_0, u_{\min}) \xrightarrow[\beta]{R} (M'_0, u');$$

and therefore by Prop. 5.04(i):

$$\|R\| > \|R'\|. \quad \square$$

**5.3. PROPOSITION.** *Let  $R$  be a complete  $\beta$ -development and  $R'$  a one-step  $n$ -projection of  $R$ . Then:*

- (i)  $R'$  is again a complete  $\beta$ -development, and
- (ii)  $\|R\| \geq \|R'\|$ .

PROOF.

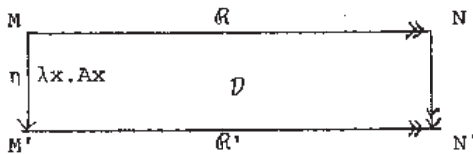

Let  $(M, u)$  be the minimal underlining of  $M$  corresponding to  $R$ . We distinguish 2 cases:

CASE 1. The head- $\lambda$  of  $\lambda x.Ax$  is in  $u$ .

Label all the  $\lambda$ 's in  $u$  with 0, except the  $\lambda$  of  $\lambda x.Ax$  (which is also a  $\beta$ -redex- $\lambda$ ); this  $\lambda$  gets label 01. The remaining  $\lambda$ 's get label 2.

So every step in the reductions  $\{\lambda x.Ax\}$ ,  $R$  is a contraction of a  $\lambda_0$  or  $\lambda_{01}$ . The same is therefore true in  $R'$ , by Lemma 3.5.

Furthermore: every contracted  $\lambda$  in  $R'$  can be traced back to a  $\lambda$  in  $M'$ , which must have label 0. This follows from the preceding remark plus Lemma 3.5 and the fact that 1 does no longer occur in labels in  $M'$ .

(\*) Now it is easily checked that every  $\lambda_0$  in  $M'$  is a  $\beta$ -redex- $\lambda$ , since  $\lambda x.Ax$  is active in the present case. (The critical case to check is:

$$\begin{array}{l} M \equiv \dots((\lambda_{01}x. \underbrace{(\lambda_0 y.B)x}_A)C)\dots \\ \lambda_{01} \downarrow \eta \\ M' \equiv \dots((\lambda_0 y.B)C)\dots \end{array} .)$$



Further we note that  $\mathcal{R}'$  is a  $\beta$ -reduction, since  $\mathcal{R}$  is so and  $\beta$ -steps propagate as  $\beta$ -steps or  $\emptyset$ -steps.

So the situation is that some  $\beta$ -redex- $\lambda$ 's in  $M'$  have label 0, the other  $\lambda$ 's in  $M'$  have label 2, and that in  $\mathcal{R}'$  only  $\beta$ -steps occur with label containing 0. Therefore  $\mathcal{R}'$  is a  $\beta$ -development.

To see that  $\mathcal{R}'$  is complete, note that there can only be fusion of  $\lambda_0$  and  $\lambda_{01}$  (not of  $\lambda_0$  and  $\lambda_2$ , or  $\lambda_{01}$  and  $\lambda_2$ ) (\*\*). This follows from the proof of Lemma 3.5: in a diagram,  $\lambda_\alpha$  and  $\lambda_\beta$  can only fuse to  $\lambda_{\alpha\cup\beta}$  if 'before' this fusion we have a  $\lambda_\alpha$ - and a  $\lambda_\beta$ -contraction in the diagram.

Furthermore, since  $\mathcal{R}$  is complete, only  $\lambda_2$ 's occur in  $N$ . Hence, since by (\*\*) the label 2 cannot grow, only  $\lambda_2$ 's occur in  $N'$ . Hence  $\mathcal{R}'$  is a complete  $\beta$ -reduction of all the  $\beta$ -redexes in  $M'$  starting with  $\lambda_0$ .

It remains to be shown that  $\|\mathcal{R}\| \geq \|\mathcal{R}'\|$ . Let us again consider two cases: there is a second  $\lambda \in \upsilon$  such that this  $\lambda$  and the  $\eta$ -redex  $\lambda_{01}x.Ax$  are "too close together", or not. (The first  $\lambda \in \upsilon$  is the head- $\lambda$  of  $\lambda_{01}x.Ax$  itself.)

$$(a) \quad M \equiv \dots(\lambda_{01}x.(\lambda_0y.B)x)C\dots$$

$$M' \equiv \dots(\lambda_0y.B)C\dots$$

$$(b) \quad M \equiv \dots(\lambda_{01}x.Ax)C\dots(A \neq \lambda_0y.B)$$

$$M' \equiv \dots AC \dots$$

Let  $\upsilon, \upsilon'$  be the set of  $\lambda_0, \lambda_{01}$  in  $M$  resp.  $M'$ . Then for both cases (a), (b) we have

$$(M, \upsilon) \xrightarrow{\underline{\beta}} (M', \upsilon').$$

Hence by Prop.5.0.4(i):

$$(1) \quad \|(M, \upsilon)\| > \|(M', \upsilon')\|.$$

Maybe  $\upsilon'$  is not the *minimal* underlining  $\upsilon'_{\min}$  corresponding to  $\mathcal{R}'$ , but that does not matter, since we have

$$(M', U') \supseteq (M', U'_{\min}),$$

hence by Prop.5.0.4(ii):

$$(2) \quad \|(M', U')\| \geq \|(M', U'_{\min})\|.$$

Combining (1) and (2) we have

$$\|R\| > \|R'\|.$$

This proves the proposition for case 1.

CASE 2. The head- $\lambda$  of  $\lambda x.Ax$  is not in  $U$ . Now the proof above breaks down at at point (\*), see p.285.

We will use the method of  $\beta\eta$ -terms. So let us underline in  $M$  the  $\lambda$ 's in  $U$  as  $\underline{\lambda}$ , and the  $\lambda$  of  $\lambda x.Ax$  as  $\underline{\lambda}$ . Result: a  $\beta\eta$ -term  $M^*$ . Extend the underlining to  $\mathcal{D}$ . Result: a  $\beta\eta$ -diagram  $\mathcal{D}^*$ .

It is clear that  $R'^*$  is a complete  $\beta$ -development, since every step in it is a  $\underline{\lambda}$ -contraction (for this is so in  $R^*$ , and  $\underline{\lambda}$ -steps propagate as  $\underline{\lambda}$ -steps or  $\emptyset$ -steps), and since no  $\underline{\lambda}$  occurs in  $N'^*$  (because no  $\underline{\lambda}$  occurs in  $N^*$ .)

Moreover, it is readily seen that we are in one of the two following cases (this is a similar distinction of cases as above; but here it is more essential):

$$(a) \quad M^* \equiv \dots \underline{\lambda}x.(\underline{\lambda}y.B)x \dots$$

$$M'^* \equiv \dots \lambda y.B \dots$$

$$(b) \quad M^* \equiv \dots \underline{\lambda}x.Ax \dots$$

( $A \not\equiv \underline{\lambda}y.B$ ; it is allowed that  $A \equiv \lambda y.B$ )

$$M'^* \equiv \dots A \dots$$

The difference between (a) and (b) is that in (a) one symbol " $\underline{\lambda}$ " is lost. Let  $(M, U)$  and  $(M', U')$  be  $M^*$  resp.  $M'^*$ , where  $\sim$  is erased.

Then in case (a):

$$(M, U) \xrightarrow[\underline{\beta}]{\underline{\lambda}y} (M', U'), \quad \text{due to } \alpha\text{-conversion.}$$

So by the same argument as in case 1,

$$\|\mathcal{R}\| > \|\mathcal{R}'\|.$$

In case (b), we claim:  $\|(M, v)\| = \|(M', v')\|$ .

Hence

$$\|(M, v)\| \geq \|(M', v')_{\min}\|, \quad \text{i.e. } \|\mathcal{R}\| \geq \|\mathcal{R}'\|.$$

Proof of the claim. The set of  $\beta$ -reductions of  $(M, v)$  is trivially seen to be "isomorphic" to that of  $(M', v')$ . Namely, underline  $\lambda x.Ax$  in  $M$  and replace all occurrences of  $\lambda x.A'x$  in a  $\beta$ -reduction of  $(M, v)$  by  $A'$ ; result: a  $\beta$ -reduction of  $(M', v')$ . And so on.

This proves the proposition for case 2.  $\square$

Before stating Prop. 5.5 and combining Prop. 5.2, 5.3 into proposition 5.6 we need a definition.

5.4. DEFINITION. Let  $\mathcal{R} = M_0 \rightarrow M_1 \rightarrow \dots$  be a finite or infinite  $\beta\eta$ -reduction.  $\mathcal{R}$  is called  $\beta$ -normal if in every  $\beta$ -step  $M_n \xrightarrow[\beta]{R_n} M_{n+1}$  in  $\mathcal{R}$ ,  $\mathcal{R}_n$  is the leftmost  $\beta$ -redex in  $M_n$ .

5.4.1. REMARK. Obviously, if  $\mathcal{R}$  is normal, then it is  $\beta$ -normal. The reason to introduce this weaker property ' $\beta$ -normal' is that  $\beta$ -normal reductions are closed under projections (prop.5.5), while normal reductions are not, as the following example shows:

$$\begin{array}{c}
 (\Omega \equiv (\lambda y. \gamma y) (\lambda y. \gamma y)). \\
 \\
 \mathcal{R}: \quad M \equiv \lambda x. \Omega [(\lambda a. I)x]x \xrightarrow[\beta]{\Omega} M \xrightarrow[\beta]{\Omega} M \xrightarrow[\beta]{\Omega} \dots \\
 \quad \quad \lambda a \downarrow \beta \qquad \qquad \quad \lambda a \downarrow \beta \quad \lambda a \downarrow \beta \\
 \mathcal{R}': \quad M' \equiv \lambda x. \Omega Ix \xrightarrow[\beta]{\Omega} M' \xrightarrow[\beta]{\Omega} M' \xrightarrow[\beta]{\Omega} \dots
 \end{array}$$

$\mathcal{R}$  is normal, but  $\mathcal{R}'$  not, since it should start with the contraction of the  $\eta$ -redex  $M'$ .

5.5. PROPOSITION.  $\beta$ -normal reductions are closed under projections.

PROOF. Consider the elementary diagram:

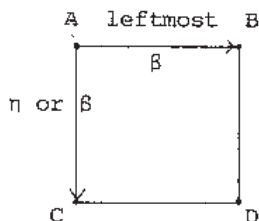

One easily checks that  $C \rightarrow D$  is an empty step, or again a leftmost  $\beta$ -contraction. (Since a  $\beta$ - or  $\eta$ -step cannot create  $\beta$ -redexes to 'its' left.)

From this it follows immediately that if  $\mathcal{R}$  is  $\beta$ -normal and  $\mathcal{R}'$  is a projection, then every  $\beta$ -step in  $\mathcal{R}'$  is a leftmost  $\beta$ -contraction, i.e.  $\mathcal{R}'$  is  $\beta$ -normal.  $\square$

5.6. PROPOSITION. One step projections of infinite  $\beta$ -normal reductions are infinite.

PROOF. Let  $\mathcal{R}$  be  $\beta$ -normal and infinite. We have to prove

- (i) one step  $\eta$ -projections of  $\mathcal{R}$  are infinite, and
- (ii) one step  $\beta$ -projections of  $\mathcal{R}$  are infinite.

(i) is Lemma 4.9 (we do not need ' $\beta$ -normality' here.)

Proof of (ii).

$\mathcal{R}$ ,  $\beta$ -normal and infinite

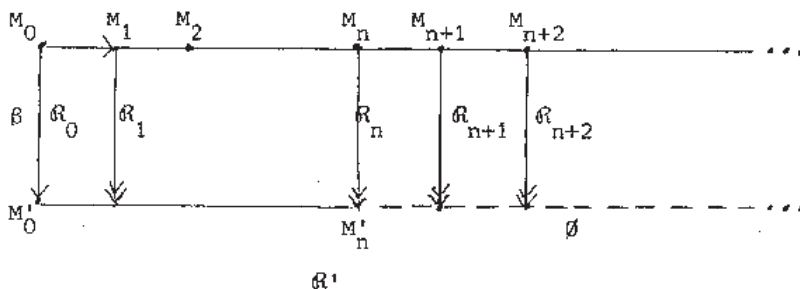

Suppose (ii) does not hold: then let  $\mathcal{R}'$  be  $\emptyset$  after say  $M'_n$ . By Prop. 5.1 and 5.3(i), the reductions  $\mathcal{R}_0, \mathcal{R}_1, \mathcal{R}_2, \dots$  are complete  $\beta$ -developments.

By 5.2 and 5.3(ii), we have  $\|\mathcal{R}_n\| \geq \|\mathcal{R}_{n+1}\| \geq \|\mathcal{R}_{n+2}\| \geq \dots$  where  $\geq$  is  $>$  every time that  $M_n \rightarrow M_{n+1}$  is a  $\beta$ -step.

But since  $\mathcal{R}$  is infinite, it contains infinitely many  $\beta$ -steps. Contradiction.  $\square$

5.7. COROLLARY. Infinite  $\beta$ -normal reductions are closed under projections.

PROOF. Immediate, by 5.5 and 5.6.  $\square$

5.8. THEOREM (Normalization for  $\lambda\beta\eta$ -calculus).

Normal reductions are normalizing.

PROOF. Let  $M$  have the  $\beta\eta$ -normal form  $N$ , and let  $\mathcal{R}$  be a reduction from  $M$  to  $N$ .

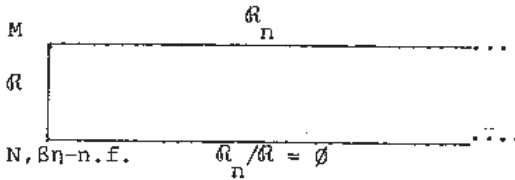

Suppose that  $\mathcal{R}_n$ , a maximal normal reduction starting with  $M$ , is infinite. Then (since  $\mathcal{R}_n$  is also  $\beta$ -normal) by the previous Corollary, the projection of  $\mathcal{R}_n$  by  $\mathcal{R}$  is still infinite.

But since  $N$  is a  $\beta\eta$ -normal form, this projection is empty. Contradiction, hence  $\mathcal{R}_n$  is finite. Hence by definition of  $\mathcal{R}_n$ , it ends in a  $\beta\eta$ -n.f. which must be  $N$  by CR.  $\square$

Now we come to the Quasi-normalization Theorem for  $\lambda\beta\eta$ . First we need a definition, analogous to Def. I.11.4:

5.9. DEFINITION. Let  $\mathcal{R} = M_0 \rightarrow M_1 \rightarrow \dots$  be a finite or infinite  $\beta\eta$ -reduction and  $R \subseteq M_n$  some redex in  $\mathcal{R}$ .

$R$  is called ( $\lambda$ -) secured in  $\mathcal{R}$  iff eventually there are no ( $\lambda$ -) residuals of  $R$  left, i.e.  $\exists m \forall m' \geq m \ M_{m'}$  contains no ( $\lambda$ -) residuals of  $R$ .

The proof of the Quasi-normalization theorem is a generalization of that for  $\lambda\beta$  (I.11.6), but not entirely straightforward. For, the analogue of Lemma I.11.5 (with 'secured' replaced by ' $\lambda$ -secured') does not hold for  $\lambda\beta\eta$ , as the following example shows.

5.10. EXAMPLE. Let  $D \equiv \lambda x y. z y x$ . (See also Example 6.2.) Let

$M_0 \equiv R \equiv \lambda_0 x. D D y x$ .  $\mathcal{R}_{qn}$  is the reduction in which each time the leftmost  $\beta$ -redex is contracted (so in  $\lambda\beta$ ,  $\mathcal{R}_{qn}$  is the normal reduction); it is a quasi-normal reduction in  $\lambda\beta\eta$ .

However, the normal  $\eta$ -redex  $R \subseteq M_0$  is not  $\lambda$ -secured in  $\mathcal{R}_{qn}$ , for  $\lambda_0$  stays alive. Yet, our requirement for the proof of the Quasi-normalization theorem is fulfilled:  $\exists n \{R\}/_n (\mathcal{R}_{qn}) = \emptyset$ . ( $\mathcal{R}$  denotes the initial segment of length  $n$  of  $\mathcal{R}$ ; see Notation I.11.1)

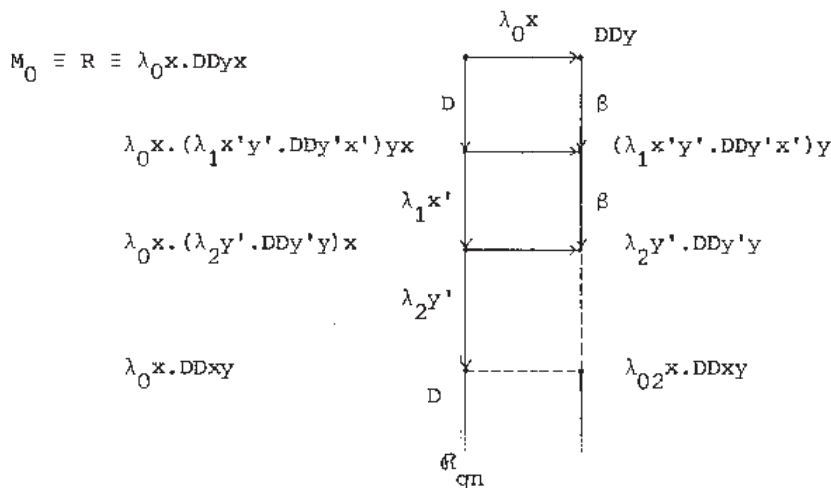

Therefore we have to make the following distinction between two concepts, which are identical in  $\lambda\beta$ , but separate in  $\lambda\beta\eta$ . One is " $R \subseteq M_0$  is  $\lambda$ -secured in  $\mathcal{R} = M_0 \rightarrow \dots$ ". The other is given by the

5.11. DEFINITION. The redex  $R \subseteq M_0$  is *absorbed* in  $\mathcal{R} = M_0 \rightarrow \dots$  if  $\exists n \{R\}/_n \mathcal{R} = \emptyset$ .

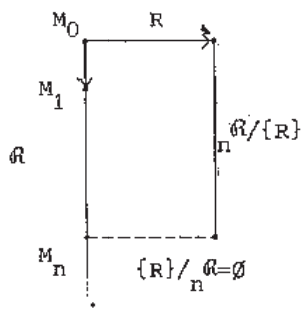

Note that in the example above the normal redex  $R$ , although not  $\lambda$ -secured in  $\mathcal{R}_{qn}$ , is absorbed by  $\mathcal{R}_{qn}$ . So we have in  $\lambda\beta\eta$ :

$$R \text{ } \lambda\text{-secured in } \mathcal{R} \Rightarrow R \text{ absorbed in } \mathcal{R}.$$

(Proof of  $\Rightarrow$ : immediately by the PM Lemma 3.7.)

Now the analogue of Lemma I.11.5 becomes:

5.12. LEMMA. Let  $\mathcal{R}_{qn} = M_0 \longrightarrow M_1 \longrightarrow \dots$  be a quasi-normal reduction in  $\lambda\beta\eta$  and  $R \subseteq M_0$  a normal ( $\beta$ - or  $\eta$ -) redex. Then:

$R$  is absorbed in  $\mathcal{R}_{qn}$ .

PROOF. CASE 1.  $R$  is a  $\beta$ -redex. Let  $\lambda_0$  be the head- $\lambda$  of  $R$ .

During the reduction  $\mathcal{R}_{qn}$ , new  $\eta$ -redexes can be created whose  $\lambda$ 's are  $< \lambda_0$ , by erasure of "obstructing variables", i.e. variable occurrences  $x \in FV(A)$  in  $H \equiv \lambda x.Ax$ , obstructing  $H$  to be an  $\eta$ -redex. Note that it is impossible that new  $\beta$ -redexes are created whose  $\lambda$ 's are  $< \lambda_0$ .

In  $\mathcal{R}_{qn}$  there can only be finitely many steps in which such a newly created  $\eta$ -redex is contracted, since there are only finitely many symbols  $< \lambda_0$  and contraction of an  $\lambda$ -redex  $< R$  diminishes their number.

These  $\eta$ -steps may demolish the  $\beta$ -redex  $R$ , by erasure of the argument of  $R$ , essentially as in the following example:

$$\begin{array}{rcl}
 \mathcal{R}_{qn} = & \lambda z. (\lambda_0 x. (\lambda y. I) z) z & \text{("obstructing variable")} \\
 & \underbrace{\lambda y | \beta \quad R} & \\
 & \downarrow & \\
 \text{(newly created } \eta\text{-redex-}\lambda & \lambda z. (\lambda_0 x. I) z & \\
 \text{to the left of } \lambda_0) & \lambda z | \eta & \\
 & \downarrow & \\
 & \lambda_0 x. I & 
 \end{array}$$

As soon as this happens (\*), we are through by the PM Lemma for  $\lambda$ -residuals (3.7); for, taking the projection of  $\{R\}$  the PM Lemma says that this projection must consist of  $\beta$ -steps whose  $\lambda$ 's trace back to  $\lambda_0$ . But as there are no  $\lambda_0$ 's in  $\beta$ -redex-position at moment (\*), this projection must be empty. I.e.  $R$  is absorbed in  $\mathcal{R}_{qn}$ .

If this demolition of  $R$  does not happen, then after finitely many normal steps in  $\mathcal{R}_{qn}$  it will be again  $R$ 's turn to be a normal redex and to be contracted in the next normal step.

CASE 2.  $R$  is an  $\eta$ -redex. A similar argument as for case 1.  $\square$

5.13. COROLLARY (Quasi-normalization theorem for  $\lambda\beta\eta$ ).

Quasi-normal reductions are normalizing.

PROOF. Analogous to the proof for  $\lambda\beta$ .  $\square$

## 6. COFINAL $\beta\eta$ -REDUCTIONS

6.1. DEFINITION. Let  $\mathcal{R}$  be a finite or infinite  $\beta\eta$ -reduction. Then  $\mathcal{R}$  is called  $(\lambda)$ -secured iff every redex in  $\mathcal{R}$  is  $(\lambda)$ -secured (Def.5.9).

6.2. REMARK.  $\mathcal{R}$  is  $\lambda$ -secured  $\implies \mathcal{R}$  is secured; but not conversely:

EXAMPLE. (i) Let  $D \equiv \lambda zxy.zzyx$  and  $C \equiv DD$  (see Example 5.10).

Then

$$\begin{array}{l} \mathcal{R} = \lambda x.Cyx \xrightarrow{\beta} \\ \lambda x.Cxy \xrightarrow{\beta} \\ \lambda x.Cyx \xrightarrow{\beta} \\ \dots \end{array}$$

is secured but not  $\lambda$ -secured because the  $\eta$ -redex  $\lambda x.Cyx$  is not  $\lambda$ -secured in  $\mathcal{R}$ . Note the flip-flop effect: off-and-on the term appears and disappears as  $\eta$ -redex.

EXAMPLE. (ii) A more subtle example of a secured but not  $\lambda$ -secured reduction is given in 6.4; there the  $\lambda$ -redex stays an  $\eta$ -redex, but loses again and again its quality as residual.

6.3. THEOREM. Let  $\alpha$  be a reduction path in  $\mathcal{G}(M)$ , the reduction graph of  $M$ . Then:

$\alpha$  is  $\lambda$ -secured  $\implies \alpha$  is cofinal.

PROOF. Analogous to the proof of Theorem I.12.3 for the  $\beta$ -case, now using the Parallel Moves Lemma 3.7 for  $\lambda$ -residuals.  $\square$

Even though the PM Lemma fails for ordinary residuals, one could hope to prove the stronger theorem "secured  $\implies$  cofinal" in a different way. But also here residuals behave badly: we will now give an example of a secured but not cofinal reduction. It is similar to the counterexample 2.3.1 to the PM lemma, but iterated by means of a fixed point construction.



6.4. EXAMPLE of a secured but not cofinal reduction.

Let  $D \equiv \lambda xy. xx(\lambda z. y(yz))$  and  $E \equiv DD$ .

$\mathbf{1} \equiv \lambda ab. ab$  (Church's numeral.)

Now consider the infinite  $\beta$ -reduction  $\alpha$ :

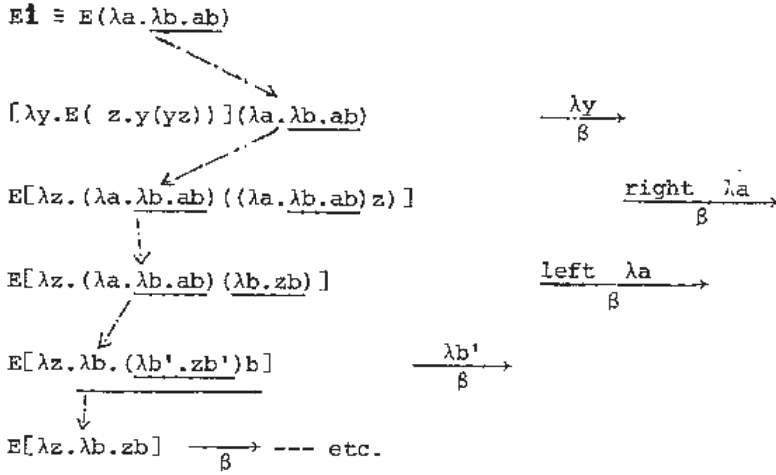

The intuition behind this example is the same as for the counterexample to the PM lemma; only, here it is arranged so that we get an *infinite* reduction (which is necessary if one wants a non-cofinal reduction; a finite, maximal reduction is cofinal by CR.) The crucial step is  $\beta$ , destroying the  $\eta$ -residual  $\lambda b. (\lambda b'. zb') b$  of  $\lambda b. ab$ . The  $\dots$  trace shows that  $\alpha$  is not  $\lambda$ -secured.

It is easily checked that  $\alpha$  is secured. However,  $\alpha$  is *not* cofinal in  $G(E\mathbf{1})$ . For,  $\mathbf{1} \equiv \lambda a. \lambda b. ab \xrightarrow[\eta]{} \lambda a. a \equiv I$ , and now consider  $E\mathbf{1} \xrightarrow[\eta]{} EI$ . We claim that no  $\beta\eta$ -reduct of  $E\mathbf{1}$  contains  $\mathbf{1}$  as subterm. From this claim it follows that  $\alpha$  cannot be cofinal in  $G(E\mathbf{1})$ , because  $\mathbf{1}$  keeps occurring in  $\alpha$ .

PROOF of the claim. The proof consists of an application of the standardization theorem for  $\beta\eta$ -reductions, and an amusing ad hoc argument.

Abbreviations: (i)  $A \circ B \equiv \lambda z. A(Bz)$   
(ii)  $E^{(0)} \equiv E$   
 $E^{(n+1)} \equiv \lambda y. E^{(n)}(y \circ y)$   
(So  $E \xrightarrow[\beta]{} E^{(1)} \xrightarrow[\beta]{} E^{(2)} \xrightarrow[\eta]{} \dots$ )

$$(iii) \quad I^{[0]} \equiv I \\ I^{[n+1]} \equiv I^{[n]} \circ I^{[n]}.$$

Now suppose  $EI \xrightarrow[\beta\eta]{\longrightarrow} c[\mathbf{1}]$ , for some context  $c[ ]$ . By the Standardization theorem, we may suppose that this reduction is standard. Hence it proceeds as follows:

$$EI \xrightarrow[\beta]{\longrightarrow} EI^{[m]} \xrightarrow[\beta]{\longrightarrow} E^{(n)} I^{[m]} \xrightarrow[\beta\eta]{\longrightarrow} c[\mathbf{1}],$$

where the latter reduction  $\xrightarrow[\beta\eta]{\longrightarrow}$  does not affect (operate in)  $E^{(n)}$ , because the whole reduction is standard; and because  $E^{(n)}$  contains no  $\mathbf{1}$  as subterm (as can easily be checked), we can write

$$c[\mathbf{1}] \equiv E^{(n)} c'[\mathbf{1}].$$

So we must have  $I^{[m]} \xrightarrow[\beta\eta]{\longrightarrow} c'[\mathbf{1}]$ . (\*)

This is however impossible. To show this, we need first a

DEFINITION.  $M$  is simple iff

$$\forall N \subseteq M \quad FV(N) \text{ has at most one element.}$$

Now  $\mathbf{1} \equiv \lambda xz.zx$  is not simple, whereas for all  $m$ ,  $I^{[m]}$  is simple.

Further it is a matter of routine to prove that the set of simple terms is closed under  $\beta\eta$ -reductions.

Hence (\*) is impossible. This proves the claim.  $\square$

6.4.1. REMARK. The use of the Standardization theorem is not essential here; it could be replaced by 'Postponement of  $\eta$ -reductions' (Lemma 4.13.1) and Standardization for  $\lambda\beta$ .

#### 6.5. KNUTH-GROSS-REDUCTIONS IN $\lambda\beta\eta$ -CALCULUS?

While the definition of Knuth-Gross reduction in  $\lambda\beta$ -calculus (in I.12) is perfectly natural, it is no longer so in  $\lambda\beta\eta$ -calculus. For consider the following naive definition:

"Let  $\mathcal{R} = M_0 \longrightarrow M_1 \longrightarrow \dots \longrightarrow M_n$  be a reduction such that

- (i) in every step a residual (in the usual sense) of a  $\beta$ -or  $\eta$ -redex in  $M_0$  is contracted, and
- (ii)  $\mathcal{R}$  is maximal with this property, i.e.  $M_n$  contains no residual of a

redex  $R$  in  $M_0$ .

Then we say  $M \xrightarrow[G_{\beta\eta}]{} N$ , in words:

" $N$  is the Knuth-Gross reduct of  $M$ ."

However,  $N$  is not uniquely determined now. Example:

$$\mathcal{R}_1 = \lambda x. (\lambda y. ay)x \xrightarrow[\eta]{\lambda y} \lambda x. ax \xrightarrow[\eta]{\lambda x} a$$

$$\mathcal{R}_2 = \lambda x. (\lambda y. ay)x \xrightarrow[\eta]{\lambda y} \lambda x. ax.$$

Both  $\mathcal{R}_1, \mathcal{R}_2$  are complete  $\beta\eta$ -developments of the total set of redexes of  $\lambda x. (\lambda y. ay)x$ .

It is possible, using  $\beta\eta$ -terms (see 5.05), to define Knuth-Gross-reduction for  $\lambda\beta\eta$ -calculus with the required properties. But the definition is not entirely straightforward; it is not immediately clear what, in that treatment, the 'total set of redexes of  $M_0$ ' (= 'total  $\beta\eta$ -underlining of  $M_0$ ') is. This is worked out in BARENDREGT, BERGSTRA, KLOP, VOLKEN [76] Chapter II.

Turning to  $\lambda$ -residuals does not help here, since FD fails for them, as shown in 2.4.1.(iv).

Therefore we will not consider Knuth-Gross-reductions in  $\lambda\beta\eta$ -calculus here. We will however consider an alternative concept, which might be just as useful.

#### 6.5.1. DEFINITION.

- (i)  $M \xrightarrow[G_{\beta}]{} N$  iff  $N$  is the Knuth-Gross reduct (w.r.t.  $\lambda\beta$ ) of  $M$ .
- (ii)  $M \xrightarrow[G_{\eta}]{} N$  iff  $N$  is the  $\eta$ -normal form of  $M$ .
- (iii)  $M \xrightarrow[G_{\beta\eta}]{} N$  iff  $\exists L \ M \xrightarrow[G_{\beta}]{} L \xrightarrow[G_{\eta}]{} N$ .

REMARK. In (ii),  $N$  is uniquely determined, by CR for  $\eta$ -reductions.

Now we will prove the following theorem; before giving the proof an immediate Corollary is mentioned.

6.5.2. THEOREM. Let  $\mathcal{R}$  be an infinite  $\beta\eta$ -reduction in which infinitely many  $\xrightarrow[G_{\beta}]{} -$ 'steps' occur and infinitely many  $\xrightarrow[G_{\eta}]{} -$ 'steps'. Then  $\mathcal{R}$  is cofinal.

6.5.3. COROLLARY. (i) Let  $\mathcal{R} = M_0 \xrightarrow{G_{\beta\eta}} M_1 \xrightarrow{G_{\beta\eta}} M_2 \xrightarrow{G_{\beta\eta}} \dots$ . Then  $\mathcal{R}$  is cofinal.

(ii) Quasi- $G_{\beta\eta}$  reductions, i.e. reductions in which infinitely many  $G_{\beta\eta}$ -steps occur, are cofinal.

PROOF of theorem 6.5.2. Let  $\mathcal{R}$  be as in the theorem. Note that replacing an initial segment of  $\mathcal{R}$  by an arbitrary reduction, yields a similar reduction.

(\*)

Let  $R \subseteq M_0$  be a  $\beta$ - or  $\eta$ -redex. We claim that  $R$  is absorbed in  $\mathcal{R}$  (see def. 5.11, or the figure.)

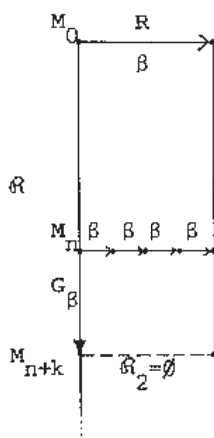

CASE 1.  $R$  is a  $\beta$ -redex. Let  $M_n \xrightarrow{G_\beta} M_{n+k} = M_n \xrightarrow{\beta} M_{n+1} \xrightarrow{\beta} \dots \xrightarrow{\beta} M_{n+k}$  be the first  $G_\beta$ -step in  $\mathcal{R}$ . Then  $\mathcal{R}_1 = \{R\}/M_0 \rightarrow \dots \rightarrow M_n$  is a complete  $\beta$ -development, by Propositions 5.1 and 5.3.(i); and it is a well-known fact that therefore  $\mathcal{R}_1$  is 'absorbed' by  $M_n \xrightarrow{G_\beta} M_{n+k}$ , i.e. that

$$\mathcal{R}_1/M_n \xrightarrow{G_\beta} M_{n+k} = \emptyset.$$

(For a proof of this fact see BARENDREGT, BERGSTRA, KLOP, VOLKEN [76], Chapter II.)

CASE 2.  $R$  is an  $\eta$ -redex. Replace  $\beta$  by  $\eta$  in the figure above. Now  $\mathcal{R}_2 = \emptyset$  because  $M_{n+k}$  is an  $\eta$ -normal form by definition of  $\xrightarrow{G_\eta}$ .

This proves the claim.

The remainder of the proof follows from (\*) and is similar to the proof of Theorem I.12.3.

□

## REFERENCES

- ACZEL, P., [78] (cit.122,123,126,130,131,132,133,141), *A General Church-Rosser Theorem*, Preprint, Manchester, July 1978.
- BAETEN, J. & M. BOERBOOM, [79] (cit.243),  *$\Omega$  can be anything it shouldn't be*, *Indag. Math.* 41 (1979) p.111-120.
- BARENDREGT, H.P. [71] (cit.4,8), *Some Extensional Term Models for Combinatory Logics and  $\lambda$ -calculi*, Ph.D. Thesis, University of Utrecht (1971).
- BARENDREGT, H.P., [74] (cit.195), *Pairing without conventional restraints*, *Z. Math. Logik Grundlag. Math.* 20 (1974) p.289-306.
- BARENDREGT, H.P., [75] (cit.197), *Open Problems,  $\lambda$ -Calculus and Computer Science Theory*, Proc. Rome Conf. 1975 (ed. C. Böhm) *Lecture Notes in Computer Science* 37, Springer p.367-370.
- BARENDREGT, H.P., [76] (cit.9,46), *A global representation of the recursive functions in the  $\lambda$ -calculus*, *Theoretical Computer Science* 3 (1976) p.225-242.
- BARENDREGT, H.P. [77] (cit.24,141), *The type free lambda calculus*, *Handbook of Math. Logic*, Barwise (ed.) North Holland, Amsterdam (1977) p.1092-1132.
- BARENDREGT, H.P., [80] (cit.17,86,108,114,141,175,216), *The Lambda Calculus, its Syntax and Semantics*, North-Holland, Amsterdam. To be published 1980.
- BARENDREGT, H.P.; J. BERGSTRA; J.W. KLOP and H. VOLKEN, [76] (cit.30,32,75, 116,256,283,296,297), *Some notes on lambda reduction*, in: *Degrees, reductions and representability in the lambda calculus*, Preprint nr.22, Univ. of Utrecht 1976, p.13-53.
- BARENDREGT, H.P.; J. BERGSTRA; J.W. KLOP and H. VOLKEN, [76'], *Representability in lambda algebras*, *Indag. Math.*, series A, vol. 79(5), Dec. 1976, p.377-387.
- BARENDREGT, H.P.; J. BERGSTRA; J.W. KLOP and H. VOLKEN, [77] (cit.116), *Degrees of sensible lambda theories*, *J. Symbolic Logic* 43 (1978) p.45-55.

- BERGSTRA, J.A. and J.W. KLOP, [77], *Invertible terms in the lambda calculus*, Preprint 58, Univ. of Utrecht 1977. To be published in *Theor. Comp. Sci.* 1980
- BERGSTRA, J.A. and J.W. KLOP, [78] (cit.75), *Strong Normalization and perpetual reductions in the lambda calculus*, Preprint Nr.99, Univ. of Utrecht 1978.
- BERGSTRA, J.A. and J.W. KLOP, [79], *Church-Rosser strategies in the lambda calculus*, *Theoretical Computer Science* 9 (1979) p.27-38.
- BERRY, G. and J.J. LÉVY, [79] (cit.11,93,104,216), *Minimal and Optimal Computations of Recursive Programs*, *JACM* 26,1 (1979).
- BÖHM, C., [66] (cit.8), *The CUCH as a Formal and Description Language*, in: *Formal Language Description Languages for Computer Programming* (ed. T.B. Steel), North-Holland, Amsterdam (1966).
- DE BRUIJN, N.G. [72] (cit.4), *Lambda calculus notation with nameless dummies, a tool for automatic formula manipulation*, *Indag. Math.* 34 (1972) p.381-392.
- CHURCH, A., [41] (cit.72,131), *The calculi of Lambda Conversion*, Princeton University Press, Princeton 1941.
- CHURCH, A., [56] (cit.135), *Introduction to Mathematical Logic*, Princeton University Press, Princeton 1956.
- CROSSLEY, J.N. (ed.), [75] (cit. vii), *Reminiscences of logicians*, (reported by J.N. Crossley) in: *Algebra and Logic, Lecture Notes in Mathematics* 450, Springer, p.1-63.
- CURRY, H.B. & R. FEYS, [58] (cit.17,113,135,136,252), *Combinatory Logic*, Vol. I, North-Holland, Amsterdam 1958.
- CURRY, H.B.; J.R. HINDLEY and J.P. SELDIN, [72] (cit.8,17), *Combinatory Logic*, Vol. II, North-Holland, Amsterdam 1972.
- VAN DAALEN, D.T., [80], *The language theory of Automath*, Ph.D. Thesis, Eindhoven 1980.
- FEFERMAN, S., [80] (cit.197), *Constructive theories of functions and classes*, in: *Logic Colloquium 1978* (eds. Boffa, van Dalen, McAloon) North-Holland, Amsterdam. To appear 1980.

- HINDLEY, J.R., [69] (cit.44), *An abstract form of the Church-Rosser theorem, I*, J. Symbolic Logic 34 (1969) p.545-560.
- HINDLEY, J.R., [74] (cit.44), *An abstract Church-Rosser theorem, II: applications*, J. Symbolic Logic 39 (1974) p.1-21.
- HINDLEY, J.R., [77] (cit.253), *The equivalence of complete reductions*, Trans. Amer. Math. Soc. 229 (1977), p.227-248.
- HINDLEY, J.R., [78] (cit.84,131,133,174,191,249,264), *Standard and normal reductions*, Trans. Amer. Math. Soc. (1978).
- HINDLEY, J.R., [78'] (cit.93,141), *Reductions of residuals are finite*, Trans. Amer. Math. Soc. 240 (1978), p.345-361.
- HINDLEY, J.R., [78''] (cit. ix), *The Church-Rosser theorem and Schroer's Finite Developments theorem*, unpublished typed notes, Swansea 1978.
- HINDLEY, J.R.; B. LERCHER and J.P. SELDIN, [72] (cit.17), *Introduction to Combinatory Logic*, Cambridge University Press, London 1972.
- HUET, G., [78] (cit.44,46,47,52,121,129,131,133,165,195,240), *Confluent Reductions: Abstract Properties and Applications to Term Rewriting Systems*, 18th IEEE Symposium on Foundations of Computer Science (1977), p.30-45. Revised version: IRIA report, Jan. 1978.
- HUET, G. & J.J. LÉVY, [79] (cit.141,174,175,190), *Call by Need Computations in Non-ambiguous Linear Term Rewriting Systems*, Rapport Laboria 359, IRIA, Août 1979.
- HUET, G. & D.C. OPPEN, [80] (cit. x), *Equations and rewrite rules: a survey*, Technical Report CSL-111 (Jan. 1980), SRI International.
- HYLAND, J.M.E., [73] (cit.38,40,43), *A simple proof of the Church-Rosser theorem*, Type script, Oxford University 1973.
- HYLAND, J.M.E., [76] (cit.24), *A syntactic characterization of the equality in some models of the  $\lambda$ -calculus*, J. London Math. Soc. (2) 12 (1976) p.361-370.
- KLOP, J.W., See also BARENDREGT et alii, and BERGSTRA-KLOP.
- KLOP, J.W., [75], *On solvability by  $\lambda$ I-terms*, Proc. Rome Conf. 1975 (see LÉVY [75]), p.342-345.

- KLOP, J.W., [77] (cit.202), *A counterexample to the Church-Rosser property for  $\lambda$ -calculus + DMM  $\rightarrow$  M*, Typed note, University of Utrecht 1977.
- KLOP, J.W., [79], *A counterexample to the Church-Rosser property for lambda calculus with Surjective Pairing*, Preprint 102, Univ. of Utrecht 1979.
- KLOP, J.W., [80], *Reduction cycles in Combinatory Logic*, in: Festschrift in honour of H.B. Curry, eds. Hindley, Seldin; Academic Press. To appear 1980.
- LÉVY, J.J., [75] (cit.27,75,88), *An algebraic interpretation of the  $\lambda\beta\kappa$ -calculus and a labelled  $\lambda$ -calculus*,  $\lambda$ -Calculus and Computer Science Theory, Proc. Rome Conf. 1975 (ed. C. Böhm) Lecture Notes in Computer Science 37, Springer Verlag 1975, p.147-165.
- LÉVY, J.J., [78] (cit.27,58,75,84,89,90,92,93,94,95,97,98,103,104), *Réductions correctes et optimales dans le lambda-calcul*, Thèse d'Etat, U. de Paris VII, Jan. 1978.
- MANNA, Z., [74] (cit.11,117), *Mathematical Theory of Computation*, McGraw-Hill 1974.
- MICALI, S., [78] (cit.116), *The characterization of cofinal strategies in  $\lambda\beta$ -calculus*, Preprint, Istituto Matematico Guido Castelnuovo-Roma, May 1978.
- MITSCHEKE, G., [76],  *$\lambda$ -Kalkül,  $\delta$ -Konversion und axiomatische Rekursionstheorie*, Habilit. Schr., Preprint Nr.274, Technische Hochschule Darmstadt 1976.
- MITSCHEKE, G., [77] (cit.224,225), *Discriminators in Combinatory Logic and  $\lambda$ -calculus*, Preprint Nr.336, Technische Hochschule Darmstadt 1977.
- MITSCHEKE, G., [79], *The standardization theorem for the  $\lambda$ -calculus*, Z. Math. Logik Grundlag. Math. 25 (1979) p.29-31.
- MORRIS, J.H., [68] (cit. v), *Lambda calculus models of programming languages*, Ph.D. Thesis, M.I.T., Cambridge (1968).
- NEDERPELT, R.P., [73] (cit.53,75,76,144,157,158,159), *Strong normalization for a typed lambda calculus with lambda structured types*, Ph.D. Thesis, Eindhoven 1973.



- NEWMAN, M.H.A., [42] (cit.46,169), *On theories with a combinatorial definition of "equivalence"*, *Annals of Math.* 43, Nr.2 (1942) p.223-243.
- O'DONNELL, M., [77] (cit.116,140,172,197,232), *Computing in Systems Described by Equations*, *Lecture Notes in Computer Science* 58, Springer Verlag, 1977.
- POTTINGER, G., [78], *Proofs of the Normalization and Church-Rosser Theorems for the typed  $\lambda$ -calculus*, *Notre Dame Journal of Formal Logic*, Vol.XIX, Nr.3, July 1978, p.445-451.
- POTTINGER, G., [79], *The Church-Rosser Theorem for the Typed  $\lambda$ -calculus with Extensional Pairing*, Preprint, March 1979, Carnegie-Mellon University, Pittsburgh.
- PRAWITZ, D., [71] (cit.127,128), *Ideas and results in Proof Theory*, in: *Second Scand. Logic Symp.*, Fenstad (ed.), North-Holland, Amsterdam 1971, p.235-307.
- ROSEN, B.K., [73] (cit.133), *Tree-Manipulating Systems and Church-Rosser Theorems*, *JACM* 20: 1 (1973), p.160-187.
- SCHÖNFINKEL, M., [24], *Über die Bausteine der mathematischen Logik*, *Math. Annalen* 92 (1924) p.305-316. Translated as: *On the building blocks of mathematical logic*, in: *From Frege to Gödel*, ed. J. van Heyenoort, Harvard Univ. Press, 1967, p.355-366.
- SCHÜTTE, K., [77] (cit.75), *Proof Theory*, Springer-Verlag 1977.
- SCOTT, D., [77] (cit.227), *Logic and programming languages*, *Comm. ACM.* vol.20 (1977), p.634-641.
- SCOTT, D., [79] (cit. vi,vii), *Lambda calculus: some models, some philosophy*, Preprint, Oxford University 1979.
- STAPLES, J., [75] (cit.44,47,50,197), *Church-Rosser theorems for replacement systems*, in: *Algebra and Logic* (ed. J.N. Crossley) *Lecture Notes in Mathematics* 450, Springer 1975, p.291-307.
- STAPLES, J., [77] (cit.45), *A class of replacement systems with simple optimality theory*, *Bull. Austral. Math. Soc.* Vol.17 (1977) Nr.3, p.335-350.
- STENLUND, S., [72] (cit.17,133), *Combinators,  $\lambda$ -terms and proof theory*, Reidel, Dordrecht 1972.

- TAIT, W., [71] (cit.172,173), *Normal form theorem for barrecursive functions of finite type*, in: *Second. Scand. Logic Symp.*, Fenstad (ed.), North-Holland, Amsterdam 1971 p.353-367.
- TROELSTRA, A.S. (ed.) [73] (cit.75), *Metamathematical Investigations of Intuitionistic Arithmetic and Analysis*, *Lecture Notes in Mathematics* 344, Springer Verlag 1973.
- DE VRIJER, R.C., [75] (cit.75), *Big trees in a  $\lambda$ -calculus with  $\lambda$ -expressions as types*, *Proc. Rome Conf. 1975* (see LÉVY [75]), p.252-271.
- DE VRIJER, R.C., [80] (cit.227), *Ph.D. Thesis*, Eindhoven, To appear 1980.
- WADSWORTH, C.P., [76] (cit.24), *The relation between computational and denotational properties for Scott's  $D_{\infty}$ -models of the lambda-calculus*, *SIAM Jour. Comput.* 5 (1976) p.488-521.
- WELCH, P.H., [75] (cit.88), *Continuous semantics and inside-out reductions*, *Proc. Rome Conf. 1975* (see LÉVY [75]) p.122-146.

## LIST OF NOTATIONS

The list of notations is divided in

(1) Abbreviations(2) Notations concerning terms

- (2.1) *Variables and metavariables*
- (2.2) *Constants*  
*Frequently occurring constants*
- (2.3) *Symbols*
- (2.4) *Terms*  
*Frequently occurring terms*
- (2.5) *Contexts*
- (2.6) *Subterms*
- (2.7) *Redexes*
- (2.8) *Labels*
- (2.9) *Trees*
- (2.10) *'Norms'*

(3) Notations concerning reductions

- (3.1) *Reductions*  
*Reduction arrows*
- (3.2) *Reduction systems*  
*related to  $\lambda$  and CL*  
*related to CRS's*

(1) Abbreviations

ARS	Abstract Reduction Systems	44
CL	Combinatory Logic	11
CP, CP'	Cofinality property	51
CR	Church-Rosser property (or Theorem)	45,150
CR <sup>+</sup>	strong version of CR	63,68,163,225, 251
CRS	Combinatory Reduction Systems	120
DL, DL', DL''	Decreasing labels (and versions)	177
DP	Disjointness property	38
DR	Decreasing redexes	180

FB	Finitely branching	52
FD	(Theorem of) Finite Developments	30,32,37,38,144
f.p.	finitely presented	165
Inc	Increasing	52
Ind	Inductive	52
NE	Non-erasing	164,170
NF	Normal Form property	47
	Set of normal forms	6
n.f.	normal form	6,46
PM	(Lemma of) Parallel Moves	69,163,254,262
PP <sub><math>\alpha, \beta</math></sub>	Postponement of $\beta$ -steps after $\alpha$ -steps	45
RPS	Recursive Program Schemes	11
SN	Strong Normalization	6,46
TRS	Term Rewriting System	121,131,133
UN	Unicity of Normal forms	46
WCR	Weak Church-Rosser property	45
WCR <sup>+</sup>	strong version of WCR	142
WCR <sup>1</sup>	restricted variant of WCR	169
WCR <sup><math>\geq 1</math></sup>	restricted variant of WCR	169
WCR <sup><math>\leq 1</math></sup>	Subcommutative	45
WCR <sub>n, <math>\mathbb{N}</math></sub>	restricted variant of WCR	47
WF	Well-foundedness property	52
WIN	Weak Innermost Normalization	172
WN	Weak Normalization	6,46
WN <sub>  </sub>	Weak Normalization w.r.t.	178

## (2) Notations concerning terms

### (2.1) *Variables and metavariables*

$v_i, a, b, c, \dots, x, y, z$	variables	1
Var	set of variables	1,121
$A, B, C, \dots, M, N, \dots,$	(informal) metavariables, ranging	1
$X, Y, Z$	over set of terms	
$Z_i^n$	formal metavariables	121
Mvar	set of metavariables	121
[x]	abstraction of variable x	121
FV(M)	set of occurrences of free variables of	
	M	164

$[x := N]$	substitution of N for x	2
$H, H', H_1, \dots$	vary over meta-terms	123
(2.2) Constants		
$A, B, C, D, \dots; P, P_1,$ $Q, R, S$	constants	1
Frequently occurring constants:		
$P_i$	constants in definable extensions of $\lambda$	9,10
$I, K, S$	basic combinators in CL	12
$P$	pairing constant	79
$[, ]$	pairing operation	77,79,151
$Q_i$	constants in CRS's	121
$R$	recursor	126
$J$	iterator	130
$0, S$	zero, successor	126,130
$\delta$	Church's $\delta$ -rules	131,132
$D$	used for non-left-linear rules	197
$D_h, D_k, D_s$ $(D, D_0, D_1)$	versions of non-left-linear constants (Surjective) Pairing	197 127,130,195
$E$	inert constant	198
<u>if .. then .. else ..</u>	branching operation	131,197,210,248
$\bar{B}$	Bar recursion operator	172
$B, \bar{B}(-, -, -)$	branching operation	209,248
$\lambda^*$	head- $\lambda$ of frozen redex	84
$Q^*$	head-constant of frozen redex	151
$^*H$	H with marked head-constant	151
$*$	marker denoting frozen redex	264
(2.3) Symbols		
$s \in M$	symbol s occurs in term M	3
$\text{Symb}(M)$	set of symbols occurring in M	18
$s, t$	vary over symbol occurrences	19
$s \dashv\vdash \rightarrow t$	descendant relation for symbols	19
$s < t$	s is to the left of t	88,113,264
$[ ]$	abstraction brackets	121

(2.4) *Terms*

$\text{Ter}(\lambda), \text{Ter}(\lambda I)$	set of $\lambda$ -terms, $\lambda I$ -terms	1
$\text{Ter}(\Sigma)$	set of $\Sigma$ -terms	121
$\text{Mter}(\Sigma)$	set of meta-terms of $\Sigma$	123
$MN^{\sim n}$	$MN \dots N$ ( $n$ times $N$ )	106
$MN \xrightarrow{\rightarrow}$	$MN_1 \dots N_m$ (for $\vec{N} \equiv N_1 \dots N_m$ )	1
$M \xrightarrow{N}$	$[M, \vec{N}]$	151
$M^I$	term $M$ plus labeling $I$	18
$\infty(M)$	$M$ has an infinite reduction	107
$\text{CR}(M)$	$M$ is CR	233
<i>Frequently occurring terms</i>		
$Y$	Curry's fixed point combinator	7
$Y_T$	Turing's fixed point combinator	7
$\omega$	$\lambda x.xx$	6
$\Omega$	$\omega\omega$	6
$I$	$\lambda x.x$	6
$K$	$\lambda xy.x$	6
$KM$	$\lambda y.M$ ( $y \notin \text{FV}(M)$ )	107
$\langle M \rangle$	$\lambda x.xM$ ( $x \notin \text{FV}(M)$ )	200
$\langle M, N \rangle$	$\lambda x.xMN$ ( $x \notin \text{FV}(MN)$ )	9

(2.5) *Contexts*

$\mathcal{C}[ \ ]$	context having one 'hole' $\square$	3
$\mathcal{C}[M]$	result of substituting $M$ in $\square$	3
$\square$	trivial context	2
$\mathcal{C}[ \dots, \ ]$	$n$ -ary context (i.e. having $n$ holes)	213, 240
$\mathcal{C}_h[ \dots, \ ]$	the head-context of a term	213

(2.6) *Subterms*

$M \subseteq N$	$M$ is a subterm of $N$	3
$H \subseteq H'$	$H$ is a submetaterm of $H'$	182
$M \subsetneq N$	$M$ is a proper subterm of $N$ (i.e. $M \subseteq N$ & $M \neq N$ )	213
$M \equiv N$	syntactical equality	4
$M \subseteq_{\sigma} N$	$M$ occurs at place $\sigma$ in $N$	128
$M \subseteq_{[ \ ]} N$	$M \in \text{Sub}_{[ \ ]}(N)$	176
$M \subseteq_{\ell} N$	$M$ is a left subterm of $N$	182
$M \subseteq_{\text{e}} N$	$M$ is an exterior subterm of $N$	186

$M \subseteq_i N$	$M$ is an interior subterm of $N$	186
$H_1 \triangleleft H_2$	$H_1$ interferes with $H_2$	130
$\text{Sub}(M)$	set of subterm occurrences in $M$	18
$\text{Sub}[\_,\_](M)$	set of memorized subterms of $M$	176
$S_1 \tau \dashv \dashv \rightarrow S_2$	descendant relation for subterms	19
$S_1 < S_2$	the headsymbol of $S_1$ is to the left of that of $S_2$	113
$M \in G_\beta(N)$	$M$ is a subterm of a $\beta$ -reduct of $N$	213

## (2.7) Redexes

$R, R', R_1, \dots, S$	redexes	4, 252
$\xrightarrow{R}$	contraction of redex $R$	4
$\text{Arg}(R)$	argument of redex $R$	59
$\mathbb{R}, \mathbb{R}(M)$	set of redex occurrences (in $M$ )	66, 179
$\text{lmc}(\mathcal{R})$	leftmost contracted redex in $\mathcal{R}$	85, 265
$\text{lmc}_\beta(\mathcal{R})$	leftmost contracted $\beta$ -redex in $\mathcal{R}$	278
$\rho(H)$	$r$ -redex, if $r = H \rightarrow H'$ and $\rho$ is some valuation	126
$R \dashv \dashv \rightarrow R'$	descendant relation for redexes ( $R'$ is a residual of $R$ )	180
$R \rightsquigarrow R'$	$R'$ is created by the contraction of $R$	180

## (2.8) Labels

$M^I$	term $M$ plus labeling $I$	18
$\langle \beta_1, \dots, \beta_n \rangle$	multiset of ordinals	63
$\mathcal{R}^I$	labeled reduction $M^I \rightarrow \dots$	99
$\lambda$	well-ordering of multisets	178
$\#$	ordinal labeling	180
(I)	concatenation of all labels in $I$ (degree of redex $\rho(H^I)$ )	183
$\alpha \times H$	$H$ in which every subterm has label $\alpha$	183
$\lambda_\alpha$ ( $\alpha \in \mathbb{N}$ )	labeled $\lambda$ in $\beta\eta$ -diagram	257
$\text{Ind}(\mathcal{R})$	union of labels of $\lambda$ 's contracted in $\mathcal{R}$	260

## (2.9) Trees

$t(M)$	term formation tree of $M$	78
$\tau(M), \tau'(M)$	alternative term formation trees of $M$ (not to be confused with the $\tau$ - (or $\tau'$ -) translation of $M$ )	123, 184

BT(M) Böhm Tree of M 216

$\Delta$

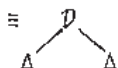

(2.10) 'Norms'

$ M $	weight of $M \in \text{Ter}(\underline{\Sigma}_w)$	34
	ordinal assigned to M	177
	length of M	203
$\ M\ $	multiset assigned to M	178
$\mathcal{L}(M)$	length of M	179
$ \mathcal{R} $	total number of symbols in $\mathcal{R}$	203
$ \Gamma $	total number of symbols in $\Gamma$	203
$ M _{\mathcal{D}}$	max. length of $\mathcal{D}$ -chains in M	233
$\ M\ _{\mathcal{D}}$	$\mathcal{D}$ -norm of M	233
$d(H)$	depth of H	238
$\ \mathcal{R}\ $		282

(3) Notations concerning reductions

(3.1) Reductions

$\mathcal{R}$	reduction (i.e. finite or infinite sequence of reduction steps)	4
$\emptyset$	empty reduction	61
$\mathcal{D}$	reduction diagram	58
$\mathcal{D}(\mathcal{R}_1, \mathcal{R}_2)$	reduction diagram determined by $\mathcal{R}_1, \mathcal{R}_2$	63
$\mathcal{R}_1 * \mathcal{R}_2$	concatenation of (appropriate) reductions	69
$\mathcal{R}_1 / \mathcal{R}_2$	projection of $\mathcal{R}_1$ by $\mathcal{R}_2$	69
$\{R\}$	reduction consisting of the contraction of redex R	69
$\mathcal{R}_s, \mathcal{R}_{st}$	standard reduction for $\mathcal{R}$	85, 265
$p(\mathcal{R})$	$\mathcal{R} / \{\text{lmc}(\mathcal{R})\}$	85, 265
$\mathcal{R}_1 \approx_L \mathcal{R}_2$	$\mathcal{R}_1, \mathcal{R}_2$ are Lévy-equivalent	89
$\mathcal{R}_1 \sim \mathcal{R}_2$	$\mathcal{R}_1, \mathcal{R}_2$ have the same first and last term	93
$\mathcal{R}_1 \approx \mathcal{R}_2$	$\mathcal{R}_1, \mathcal{R}_2$ are permutation equivalent	93
$\sim_s, \sim_S, \sim_{R'}, \approx_B$	other equivalences between reductions	93, 94
RED(M)	set of finite reductions starting with M	92



$\rightleftarrows$	'meta-reduction' of reductions	93, 190
$[\mathcal{R}]^{\uparrow}$	$\{\mathcal{R}'/\mathcal{R}' \Longrightarrow \mathcal{R}\}$	107
$\mathcal{R}^I$	labeled reduction $M^I \rightarrow \dots$	99
$\Gamma$ (AAAAAAAA)	conversion	102, 203, 232
$\mathcal{R}(n)$	n-th term in $\mathcal{R}$	113
$n(\mathcal{R})$	initial segment (of length n) of $\mathcal{R}$	113
$(\mathcal{R})_n$	$\mathcal{R}_n(\mathcal{R})$	113
$\text{Red}(\Sigma)$	set of reduction rules of $\Sigma$	120
$r$	reduction rule	126
$r_A$	labeled versions of $r$	138
$\underline{r}$	underlined version of $r$	139
$r_{[r]}$	$r$ plus memory	154
$r^{-1}$	converse of $r$	203
$G(a)$	reduction graph of $a$	50, 115
$G_{\beta}(M)$	$\beta$ -reduction graph of $M$	115
$G_{\Sigma}(M)$	$\Sigma$ -reduction graph of $M$	162
$G_{\beta}^c(M)$	condensed $\beta$ -reduction graph of $M$	213

### Reduction arrows

$\xrightarrow{\alpha}$	$\alpha$ -reduction	3
$\equiv_{\alpha}, \equiv$	syntactical equality	3, 4
$\xrightarrow{\beta}$	$\beta$ -reduction	3
$\overset{=}{\beta}$	$\beta$ -convertibility	4
$\longrightarrow$	transitive reflexive closure of $\longrightarrow$	4, 44
$\xrightarrow{\equiv}$	reflexive closure of $\longrightarrow$	44
$\xrightarrow{R}$	contraction of redex $R$	4
$\xrightarrow{CL}$	reduction in CL	13
$\xrightarrow{\tau}, \xrightarrow{\tau'}$	translation from $\lambda$ to CL	13
$\tau(M), \tau'(M)$	$\tau, \tau'$ -normal form of $M$ (i.e. $\tau, \tau'$ -translation of $M$ )	13
$\dashv\dashv\rightarrow$	descendant relation	19, 139, 180
$\xrightarrow{\beta_A}$	labeled $\beta$ -reduction	19
$\xrightarrow{\underline{\beta}}$	underlined $\beta$ -reduction	23
$\xrightarrow{\beta_{HW}}$	Hyland-Wadsworth labeled $\beta$ -reduction	24
$\xrightarrow{\beta_L}$	Lévy-labeled $\beta$ -reduction	28
$\xrightarrow{\beta_n}$	n-ary $\beta$ -reduction ('fast' $\beta$ -reduction]	37

$\xrightarrow{\alpha^{-1}}$ or $\xleftarrow{\alpha}$	converse of $\xrightarrow{\alpha}$	44
$\dashrightarrow$ , $\dashrightarrow$	in a diagram: existential meaning	45
$\dashrightarrow$	empty step in a diagram	61
$\xrightarrow{k}$	k-reduction ('forgetful' reduction)	79,153
$\kappa(M)$	k-normal form of M	79,176
$\rightsquigarrow$ or $\xrightarrow{\text{shift}}$	shift reduction	79,152,154
$\rightleftharpoons$	meta-reduction	93,190
$\xrightarrow{\text{l.m.}}$	leftmost reduction	113,204
$\xrightarrow{\text{KG}}$	Knuth-Gross reduction	117
$\rightsquigarrow$	creation of redexes	180
$\xrightarrow{\text{i.m.}}$	innermost reduction	180
$M \downarrow N$	M, N have a common reduct	198
$\xrightarrow{h}$	head reduction	213
$\dashrightarrow$ der	derivation	213
$\xrightarrow{n}$ , $\xrightarrow{n}$	reductions in $\text{CL}\square$	241,242
$\xrightarrow{\eta}$	$\eta$ -reduction	249
$\xrightarrow{\beta\eta}$	$\beta\eta$ -reduction	249
$\rightsquigarrow$	propagation of reduction steps in a diagram	257
$\xrightarrow{G_\beta}, \xrightarrow{G_\eta}, \xrightarrow{G_{\beta\eta}}$	Knuth-Gross reductions in $\lambda\beta\eta$	296

### (3.2) Reduction systems

A, B	Abstract Reduction Systems	44
$A \subseteq B$	A is a substructure of B	50
<i>related to <math>\lambda</math> and CL</i>		
$\lambda, \lambda\beta$	$\lambda$ - (or $\lambda\beta$ -) calculus	5
$\lambda\text{I}$	$\lambda\text{I}$ -calculus	5
$\lambda\text{P}$	definable extension of $\lambda$	10
CL	Combinatory Logic	11
$\lambda_A$	indexed (or labeled) $\lambda$ -calculus	18
$\underline{\lambda}, \underline{\lambda\beta}$	underlined $\lambda$ -calculus	23
$\underline{\lambda\text{P}}$	underlined $\lambda\text{P}$ -calculus	23
$\lambda^{\text{HW}}$	Hyland-Wadsworth $\lambda$ -calculus	24
$\lambda^{\text{L}}$	Lévy's $\lambda$ -calculus	27
$\lambda^{\tau}$	typed $\lambda$ -calculus	27
$\lambda^{\text{L,P}}$	restricted $\lambda^{\text{L}}$	29

$\lambda\beta_m$	fast $\lambda\beta$ -calculus	37
$\underline{\lambda\beta}_m$	underlined version of $\lambda\beta_m$	38
$\lambda IP$	definable extension of $\lambda I$	72
$\lambda_{[ , ]}$	$\lambda$ -calculus plus pairing	79
$\lambda I_{[ , ]}$	$\lambda I$ -calculus plus pairing	81
$CL^T$	typed CL	172
$CL\Box$	CL plus black boxes	241
$\lambda\eta, \lambda\beta\eta$	$\lambda\eta$ - (or $\lambda\beta\eta$ -) calculus	250
$\underline{\lambda\beta\eta}$	double underlined version of $\lambda\beta\eta$	283
<i>related to CRS's</i>		
$\Sigma \models P$	$\Sigma$ has the property $P$ ( $P$ is true in $\Sigma$ )	25
$\underline{\Sigma}$	underlined version of $\Sigma$	32,139
$\underline{\Sigma}_w$	$\Sigma$ plus underlining and weights	33
$\Sigma$	Combinatory Reduction System	120
$\Sigma_1 \subseteq \Sigma_2$	$\Sigma_1$ is a substructure of $\Sigma_2$	121
$\Sigma_1 \oplus \Sigma_2$	direct sum of CRS's $\Sigma_1, \Sigma_2$	134
$\Sigma_A$	labeled version of $\Sigma$	138
$\Sigma_f$	$\Sigma$ where substitution is 'frozen'	142
$\Sigma^f$	version of $\Sigma$ in function notation	240
$\Sigma_{f\beta}$	$\Sigma_f$ plus fast $\beta$ -reduction	142
$\Sigma_{[ , ]}$	$\Sigma$ plus memory	151
$\Sigma' [ , ]$	variant of $\Sigma_{[ , ]}$	175
$T$	Gödel's $T$	179
$\Delta_i$ ( $i = k, s, h$ )	non-left-linear CRS's	233
$\Delta_i^{(2)}$ ( $i = k, s, h$ )	binary versions of $\Delta_i$ ( $i = k, s, h$ )	239

## INDEX

- Absorbed 291
- absorption 251
- Abstract Reduction System (ARS) 44
- abstraction ( $\lambda$ -) 1
- abstractor 3
- adequate labeling 99
- alphabet of CRS 121
- $\alpha$ -conversion 3
- ancestor 19, 139
- anti standard pair 96, 190
- $\alpha$ -reduction 3
- application 1, 121
- argument 5
- arity 10, 120, 121
- associate 160
- association to the left 1
  
- Bar recursion operator 172
- bar recursive terms 172
- $\beta_A$ -reduction 19
- $\beta_{HW}$ -reduction 24
- $\beta_L$ -reduction 28
- $\beta$ -normal 288
- branching operation 197, 209, 246
- $\beta$ -redex 3
- $\beta$ -reduction 3
- black box 240
- Böhm tree 216
- bound 2
- bounded predicate P (for  $\lambda^L$ ) 29
  
- Church-Rosser property 45
- Church-Rosser Theorem 57, 68, 150, 163, 224, 225, 251
- Church-Rosser, weakly (WCR) 45
  
- closed
  - diagram 164
  - meta-term 123
  - rule 166
  - term 2
  - under projections 168, 281
  - under reduction, substitution 224
- cofinal 51, 293
- cofinality property (CP) 51
- coincidence 251
- color degree 39
- colors 39
- Combinatorial Completeness (CC)
  - 7, 16, 247
- combinators 11
- Combinatory Logic (CL) 11
- Combinatory Reduction Systems (CRS)
  - 119, 120, 121
- commutes 45
- commutes weakly 44
- complete development (c. dev.)
  - 66, 140, 252
- concatenation 69
- condensed reduction graph 213, 215
- confluent 46
- conservative extension 50, 220
- consistent 50
- constants 1, 126
- construction of reduction diagrams 58
- context 2
- contracted in  $\mathcal{R}$  84
- contraction 4
- contractum 4
- contraction scheme 126, 131, 132

- convertibility 4
- conversion 102, 203
  - ( $\alpha$ -) 3
- creation of redexes 25, 140
- creator redex 188, 191
- Curry's fixed point combinator ( $\Upsilon$ ) 7
- $\mathcal{D}$ -chain 233
- decreasing labeling (DL) 177
- decreasing redex labeling (DR) 180
- definable extensions 9
- definable extension of  $\lambda I$  72
- definition by cases 130
- degree 180, 185
  - of  $\beta_{HW}$ -redex 24
  - of  $\beta_L$ -redex 28
- $\delta$ -rules of Church 131, 132
- depth 238
- derived terms 213
- descendant 19, 139
- developments
  - complete 66
  - fast 37
  - Finite 30, 37, 39, 163, 256
  - in CRS 140
  - in  $\lambda, \lambda^P$
- diminishing 239
- direct sum  $\oplus$  134
- $\mathcal{D}$ -norm 233
- $\mathcal{D}$ -preredex 233
- Elementary diagram (e.d.) 59
- empty step 59
- equivalence of reductions 89, 93
- erasing step 107
- erasure 72, 251
- expansion 274
- extension 50
- external label 186
- external subterm 186
- Fast development 38
- Finite Developments 30, 37, 39, 163, 256
- finitely branching (FB) 52
- finitely presented (f.p.) 165
- fixed points 7
- fixed point combinator
  - Curry's 7
  - Turing's 7
  - with parameters 8
- Fixed Point Theorem 7, 224
  - multiple 9
- flat combinator 12
- forgetful reduction rule 153
- formation tree 78
  - $t(M)$  78
  - $\tau(M)$  123
  - $\tau'(M)$  184
- free variables 2
- frozen 91, 152
- function notation 122, 240
- function part 5
- FV(M) 2
- FV(M) 164
- Gödel's  $T$  75, 179
- good 34
- graph, reduction - 50
- Head normal form (h.n.f.) 213
- head reduction 16, 213
- height of Lévy-label 29
- Hindley-Rosen Lemma 47
- homomorphisms from  $\lambda^L$  29

- Increasing (Inc) 52
- index(ing) 18
- induced concept of descendant 22
- inductive (Ind) 52
- inert 10
- infinite term 107
- initial labeling 19, 138
- innermost redex 76
- inside-out reduction 88
- interdefinabilities 200
- interference 129, 130
- internal label 186
- internal labeling 140, 141
- internal subterm 186
- Iterator ( $J$ ) 130, 179
- k-expansion 153
- k-normal form 79
- Knuth-Gross reduction 117, 295
- k-reduction 79
- labeling 18
  - adequate 99
  - initial 138
  - strongly adequate 108
- labeled  $\beta$ -reduction 18
- labeled CRS 137
- labels 18
  - Hyland-Wadsworth (HW) 24
  - Lévy- 27, 182
  - multiple 24
- left-linear 119, 126
- leftmost redex 16, 113
- left-normal 189
- Lévy-equivalent 89
- leftmost contracted redex
  - (lmc) 85, 265
- Lévy's  $\lambda$ -calculus ( $\lambda^L$ ) 27
- L-labeled CRS 183
- lmc( $\mathcal{R}$ ) 85, 265
- $\lambda$ -abstraction 1
- $\lambda(a)$ -reductions 131, 132, 133, 136
- $\lambda$ - (or  $\lambda\beta$ -) calculus 5
- $\underline{\lambda}$ - (or  $\underline{\lambda}\beta$ -) calculus 23
- $\lambda$ II-calculus 215
- $\lambda$ I-terms 1
- $\lambda^L$ -calculus 27
- $\lambda$ -path 257, 258
- $\lambda P$ -calculus 10
- $\underline{\lambda P}$ -calculus 23
- $\lambda$ -residuals 254
- $\lambda$ -secured 290
- $\lambda$ -standard 264
- $\lambda^T$ -calculus 27
- Marker \* 84
- memory part 151
- meta-metavariables 123
- meta-reduction 96, 190
- meta-terms 123
- metavariables 12, 120
- multiple fixed point theorem 9
- multiplicity 33
- multiset 63
- Nederpeit's Lemma 47
- Newman's Lemma 47
- noetherian 46
- non-ambiguous 119, 130
- non-erasing 164, 170
- normal form (n.f.) 6
- normal form property (NF) 220, 228
- normal redex 113, 279
- normal reduction 113, 280
- Normalization Theorem 114, 194, 290
- normalizing

- weakly 6, 46
- strongly 6, 46
- Pairing 130
  - Surjective 127, 133, 195
- Parallel Moves Lemma (PM) 69, 163
  - for  $\lambda\beta\eta$  254, 262
- permutation equivalence 96
- $P_i$ -redexes 10
- Postponement of  $\beta$  after  $\alpha$  (PP $_{\alpha, \beta}$ ) 45
- P-normal form 78
- Postponement of  $\eta$ -reductions 278
- projection 69
- Proof Theory 127, 133
- propagation 61, 257
- proper indexing 182
- proper rule 21
- Quasi-Knuth-Gross reduction 118
- quasi-normal reduction 113
- Quasi-normalization Theorem ( $\lambda\beta\eta$ ) 293
- Recursive Program Schemes (RPS) 11, 133
- recursor (R) 75, 122, 126, 133
- redex
  - $\beta$ - 3
  - contracted in  $\mathcal{R}$  84
  - creation of 25
  - frozen 91
  - head 213
  - I-, K-, S- 12
  - leftmost 113
  - normal 113
  - $P_i$ - 10
  - safe 14
  - secured 114
- reduction
  - $\alpha$ - 3
  - $\beta$ - 3
  - $\underline{\beta}$ - 23
  - $\beta_A$ - 19
  - $\beta_{HW}$ - 24
  - $\beta_L$ - 28
  - equivalence of 89
  - eventually leftmost 113
  - head 16
  - inside-out 88
  - k- 79
  - Knuth-Gross 117
  - labeled  $\beta$ - 18
  - leftmost 16
  - maximal 113
  - normal 113
  - quasi-normal 113
  - secured 115
  - special 108
  - standard 84
  - reduction by cases 224, 225
  - reduction diagram 58
  - reduction graph 50
  - reduction relation 126
  - reduction rule 120, 126
  - regular 129, 131, 133,
  - replacement system 44
  - residuals 19, 139
    - for  $\lambda\beta\eta$  252
    - $\lambda$ - 254
  - Safe  $\beta$ -redex 4
  - safe
    - redex 14
    - reduction 14
  - secured

- redex 114, 290
- reduction 115, 290
- shift normal form 154
- shift rule 152
- simultaneous substitution 5
- singleton redex 182
- special 203
- special reduction 108
- standard reduction 84, 190, 264
- standardization diagram 85
- Standardization Theorem 87, 90, 101, 103, 193, 276
- strongly normalizing (SN) 6
- subcommutative ( $WCR^{\leq 1}$ ) 45
- Sub(M) 18
- Sub<sub>[,]</sub>(M) 176
- submetaterm 182
- substitution operator 2
- substructure 50
- subterm 3
- subword 34
- Surjective Pairing (SP) 127, 133, 195
- syntactical accident 92
- syntactical equality 4
  
- Term formation tree  $t(M)$  78
  - $\tau(M)$  123
  - $\tau'(M)$  184
- Term Rewriting Systems (TRS) 121, 131, 133
- "too close together" 253
- tracing in diagrams 258
- tracing subterms 18, 257
- transfinite induction 62
- translation  $\tau, \tau'$  13
- tree 78, 184, 123, 216
- trivial context 3
- trivial e.d. 62
- trivial step 59
- Turing's fixed point combinator ( $Y_T$ ) 7
- typed  $\lambda$ -calculus 27
- tracing subterms 18, 257
  
- Underlined reduction system 32
- Underlining 22
  - reduced 23
- Unicity of normal forms (UN) 46, 231, 220
  
- Variables 1
- Valuation 125
  
- Weak Innermost Normalization (WIN) 172
- weakly Church-Rosser (WCR) 45
- weakly normalizing (WN) 6
- weakly normalizing w.r.t.  $\|\cdot\|$ 
  - $(WN_{\|\cdot\|})$  177
- weight 33



## SAMENVATTING

In de volgende bladzijden wil ik proberen de achtergrond en de inhoud van dit proefschrift te schetsen; daarbij richt ik me vooral tot degenen die niet bekend zijn met het onderwerp. (Een nauwkeuriger beeld wordt gegeven in de 'Introduction and Summary'.)

Er zijn ruwweg twee ingangen tot het onderwerp, de eerste van filosofische aard ('Grondslagen van de Wiskunde') en de tweede van praktisch-toegepaste aard ('Computer Science').

Laten we beginnen met het grondslagen-aspect. Zoals bekend, kan de hele wiskunde (in zekere zin) beschreven worden d.m.v. de Verzamelingentheorie (bijvoorbeeld het systeem ZF van Zermelo en Fraenkel), onder het motto 'alles is een verzameling'. Een concurrerende visie (qua aantal aanhangers veruit in de minderheid) propageert als fundamenteel begrip niet 'verzameling', maar 'functie'. Een voorbeeld: de functie  $f: \mathbb{N} \rightarrow \mathbb{N}$  met  $f(x) = (x^2+1)x$  wordt genoteerd als  $\lambda x. (x^2+1)x$ , waarmee dus  $f(3) = (\lambda x. (x^2+1)x)^3 = (3^2+1)3$  (het argument 3 wordt voor alle  $x$ -en gesubstitueerd). In de "pure"  $\lambda$ -calculus komen in eerste instantie geen natuurlijke getallen of operaties als 'kwadraat' voor; de enige objecten in kwestie zijn de functies zelf, en de enige operatie is applicatie van een functie  $f$  op zijn argument  $x$ ; resultaat  $fx$ . Daarbij zijn we zeer liberaal: het domein van zo'n functie is 'alles' en zelf-applicatie wordt dus niet geschuwd. Zo is er bijv. een functie  $F = \lambda xy.yx$  die zijn twee argumenten omkeert:  $Fab = (\lambda xy.yx)ab = ba$ . Merk op dat we zuinig zijn met haakjes en niet  $F(a,b)$  schrijven;  $n$ -aire functies worden namelijk teruggebracht tot unaire functies, via een simpele identificatie. (Bijv. de binaire functie  $+$  =  $\lambda(x,y). x+y \in (\mathbb{N} \times \mathbb{N}) \rightarrow \mathbb{N}$  kan geïdentificeerd worden met de unaire functie  $f = \lambda x. (\lambda y.x+y)$ , afgekort tot  $\lambda xy.x+y$ , d.w.z. de functie  $f \in \mathbb{N} \rightarrow (\mathbb{N} \rightarrow \mathbb{N})$  met  $f(x) = \lambda y.x+y \in \mathbb{N} \rightarrow \mathbb{N}$ . Hierbij staat  $A \rightarrow B$  voor de verzameling functies van  $A$  naar  $B$ .)

Een ander voorbeeld is de functie  $D = \lambda x.xx$  die zijn argument verdubbelt:  $Da = (\lambda x.xx)a = aa$ . Dit leidt tot een merkwaardig object, namelijk  $DD$ ; bij 'uitrekenen' komen we in een cykel:  $DD = (\lambda x.xx)D = DD$ . Natuurlijk hebben we ook de 'gewone' compositie  $C$  van functies  $f, g$ ; in plaats van  $f \circ g$  schrijven we  $Cfg$ . In feite is dus  $C = \lambda xyz. x(yz)$ ; want dan inderdaad  $Cfgx (= (f \circ g)x) = f(gx)$ .



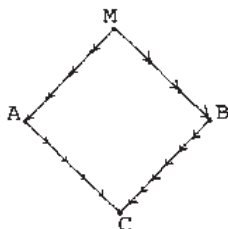

Een van de opmerkelijkste feiten bij dit rekenen met ' $\lambda$ -termen' is dat

elke functie  $F$  een vast punt  $p$  heeft, dus  $Fp = p$ . Namelijk, neem bij gegeven  $F$  eenvoudig  $p = D(F \circ D)$ . Dan immers  $p = D(F \circ D) = (F \circ D)(F \circ D) = F(D(F \circ D)) = Fp$ ! Deze zo eenvoudig af te leiden Fixed Point stelling in de  $\lambda$ -calculus hangt samen met Gödel's Onvolledigheidsstelling en met een fundamentele stelling in de Recursietheorie.

Bij de genoemde voorbeelden is het duidelijk dat er een zekere asymmetrie zit in de gelijkheid (=); er is sprake van uitrekenen, *reduceren* genaamd. Bijvoorbeeld,  $Da$  wordt gereduceerd tot  $aa$ ; notatie:  $Da \rightarrow aa$ . Meestal bevat een  $\lambda$ -term  $M$  verschillende onderdelen die gereduceerd kunnen worden (zoals bijvoorbeeld ook de berekening van  $(3+2) \cdot (5+7)$  op verschillende manieren begonnen kan worden) en we kunnen de term  $M$  dus op verschillende manieren uitrekenen. A priori is het mogelijk dat er dan ook verschillende 'uitkomsten' gevonden worden, waarbij een 'uitkomst' (officieel: normaalvorm) een term is die niet verder gereduceerd kan worden. Dat zou, intuïtief gesproken, niet in de haak zijn. Gelukkig zegt een fundamentele stelling (van Church en Rosser) dat wanneer een term  $M$  op twee manieren een aantal stappen gereduceerd wordt, zeg tot  $A$  en  $B$ , er verdere reducties zijn die tot een gemeenschappelijk reduct  $C$  van  $A, B$  leiden:



En deze stelling garandeert (na nog een kort argument) de uniciteit van de uitkomst, als die er tenminste is. (Bijv. de berekening van  $DD$  leidt niet tot een uitkomst:  $DD \rightarrow DD \rightarrow \dots$ )

Het probleem bij het bewijzen van deze Church-Rosser eigenschap is als volgt. Als elk tweetal reductiestappen  aangevuld zou kunnen worden tot een 'tegel' , zou het niet moeilijk zijn het gemeenschappelijk reduct  $C$  te vinden; in bovenstaande figuur door 12 tegels te leggen. Helaas zijn de tegels meestal van de vorm  of , bijvoorbeeld; en dan kan het plaveien om  $C$  te vinden gemakkelijk uit de hand lopen:

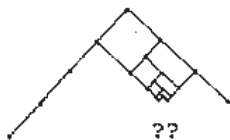

Deze 'Church-Rosser' problematiek, en het al of niet eindigen ('normaliseren') van reducties, hangen nauw met elkaar samen en vormen het centrale thema van dit proefschrift.

De  $\lambda$ -calculus werd in de dertiger jaren ontwikkeld. Er is een verwant systeem, genaamd Combinatorische Logica (in 1924 ontdekt), dat even sterk is als de  $\lambda$ -calculus; de twee systemen zijn in zekere zin vertalingen van elkaar. Alles wat  $\lambda$ -calculus kan, voor de Grondslagen van de Wiskunde, kan CL ook. Bovendien heeft CL het voordeel dat er geen gebonden variabelen zijn (zoals de  $x$  in  $\lambda x.xx$ ); filosofisch prettig want het is problematisch wat gebonden variabelen eigenlijk 'betekenen'. In CL zijn er drie basis combinatoren  $I$ ,  $K$ ,  $S$  met als regels voor reductie:

$$\begin{aligned}Ix &\rightarrow x \\Kxy &\rightarrow x \\Sxyz &\rightarrow (xz)(yz).\end{aligned}$$

Dus  $I$  is de Identieke 'functie',  $K$  is de functie die Konstante functies 'maakt' (immers  $Kx$  is een functie met  $y \mapsto x$  voor all  $y$ ), en  $S$  doet iets dat in feite op hetzelfde blijkt neer te komen als Substitutie in de  $\lambda$ -calculus. Substitutie in  $\lambda$ -calculus wordt a.h.w. geëlimineerd ten gunste van *concatenatie* (simpelweg achter elkaar zetten) in CL, en het laatste is natuurlijk een eenvoudiger operatie.

Een voorbeeld. De 'combinator'  $SII$  doet hetzelfde als de verdubbelaar  $D$  boven:

$$SIIx \rightarrow (Ix)(Ix) \rightarrow x(Ix) \rightarrow xx.$$

CL heeft ook weer zijn nadelen: de beschrijving door een  $\lambda$ -term van een 'rekenproces' is veel directer; de corresponderende combinator is veel ingewikkelder. Een voorbeeld van een typisch verschil in syntactisch gedrag: het is niet moeilijk  $\lambda$ -termen  $M$  te vinden zodat  $M$  met al zijn 'reducten' precies een reductie-'loop' vormt:

( $DD$  was al zo'n loop.)



In CL daarentegen genereert de aan-

wezigheid van een cyclische reductie er meteen oneindig veel in de reductie-graph. (Dit is goed te zien bij de CL-vertaling ( $SII$ ) ( $SII$ ) van  $DD$ .)

We zouden kunnen zeggen dat CL en  $\lambda$ -calculus een analyse geven van rekenprocessen. Een CL- of  $\lambda$ -term is eigenlijk een 'programma', maar dan

één in pure vorm, ontdaan van alle 'syntactic sugar' waaronder de essentie van echte programma's soms schuil gaat. De  $\lambda$ -calculus (of CL) is te zien als een 'oer-programmeertaal', waarin veel van de essentiële aspecten van echte programmeertalen in pure vorm bestudeerd kunnen worden. (Zo bezien is zelf-applicatie (FF) niet vreemd: een programma kan zichzelf als input hebben.) Reductie-stappen zijn atomaire berekeningen, zoals in Turing machines het opschuiven van de band, het veranderen van inwendige toestand, het drukken van een symbool, etc., de atomaire handelingen zijn. (Alles wat een Turing machine kan, kan CL of  $\lambda$ -calculus ook.)

Hiermee zijn we terecht gekomen van het Grondslagenaspect op dat van de Computer Science. Het reductiesysteem CL is een voorbeeld van een Term Reductie Systeem (TRS). TRS'en komen al in elementaire wiskunde voor, bijvoorbeeld

$$\left\{ \begin{array}{l} x+0 \rightarrow x \\ x+(y+1) \rightarrow (x+y)+1 \\ x.0 \rightarrow 0 \\ x.(y+1) \rightarrow x.y+x, \end{array} \right.$$

de definitie 'vergelijkingen' voor + en . , vormen een TRS. Gegeven de term  $(2+3).(5+7)$  dan kan deze, op verschillende manieren, m.b.v. de reductie-regels uitgerekend worden. Ook hier dus de 'Church-Rosser problematiek' en de vraag of de berekening eindigt. Voor deze TRS zijn die vragen niet zo moeilijk positief te beantwoorden; de regels vertonen de prettige omstandigheid (net als die voor CL boven), dat de variabelen  $x,y,z$  aan de linkerkant van de regels paarsgewijs verschillend zijn (rechts niet). Zulke TRS-en heten *lineair*. Een simpel voorbeeld van een niet-lineaire TRS krijgen we door aan bovenstaande regels de volgende reductie-regel voor de inverse toe te voegen:

$$x+(-x) \rightarrow 0.$$

Het dubbel voorkomen van de  $x$  aan de linkerkant is lastig om de volgende reden. Stel  $x \rightarrow x'$ , en beschouw de 'divergente' bereken-stappen

$$\begin{array}{c} x + (-x) \longrightarrow 0 \\ \downarrow \\ x' + (-x) \end{array}$$

dan moeten we om een gemeenschappelijk reduct te vinden eerst de verstoreng van de a.h.w. in evenwicht verkerende term  $x+(-x)$  compenseren:

$$\begin{array}{ccc} x+(-x) & \longrightarrow & 0 \\ \downarrow & & \downarrow \\ x'+(-x) & \rightarrow x'+(-x') & \longrightarrow 0 \end{array}$$

Het hoofdresultaat van dit proefschrift is nu, dat door die non-lineariteit van reductie-regels de Church-Rosser eigenschap (CR) beslissend verstoord wordt, als het reductie-systeem in kwestie tenminste 'sterk genoeg' is. Voor de eenvoudige niet-lineaire TRS  $\Sigma$  van boven geldt CR nog wel. Maar als we een 'mixture' zouden bekijken van  $\lambda$ -calculus plus  $\Sigma$  (met termen zoals  $\lambda z.((\lambda xy.x+(-y)+z))$ ), dan geldt CR niet langer!

Overigens: het falen van CR impliceert nog niet dat een term dan tot verschillende uitkomsten gereduceerd kan worden. Inderdaad blijkt in de onderzochte systemen dat daar de uniciteit van normaalvormen blijft gelden, ook al geldt CR niet.

Zulke non-lineaire systemen komen in verschillende gebieden tevoorschijn; behalve in 'pure'  $\lambda$ -calculus en als TRS-en die samenhangen met algebraïsche structuren (zoals het voorbeeld boven), ook in de Bewijstheorie en in de Theoretische Informatica, bij een stel regels als:

$$\begin{array}{ll} (\underline{\text{if true then } x \text{ else } y}) \rightarrow x \\ (\underline{\text{if false then } x \text{ else } y}) \rightarrow y \\ (\underline{\text{if } z \text{ then } x \text{ else } x}) \rightarrow x \quad (*) \end{array}$$

waar het venijn van de niet-lineariteit in regel (\*) zit.

Uit bovenstaande zal het duidelijk zijn dat al deze problemen een 'syntactisch karakter' hebben. Dit proefschrift beperkt zich tot die kant van de zaak; semantische aspecten ('wat betekent een  $\lambda$ -term? Is er een *model* voor de  $\lambda$ -calculus?') komen hier niet aan bod.

Curriculum vitae

Op 19 december 1945 ben ik in Gorinchem geboren. Van 1957 tot 1963 bezocht ik het Stedelijk Gymnasium te 's-Hertogenbosch, waarna ik begon met de Wis- en Natuurkundestudie aan de Rijksuniversiteit Utrecht. Na een studie-onderbreking, o.a. voor een part-time Leraarschap aan een MAVO-school gedurende twee jaar en het vervullen van de militaire dienstplicht (van januari 1970 tot juli 1971; het kandidaatsexamen Wis- en Natuurkunde met bijvak Sterrekunde behaalde ik in juli 1970), heb ik de Wiskundestudie in 1972 hervat.

In mijn afstudeerjaar (1974-1975) was ik assistent bij Van Dalen en Barendregt. Onder leiding van laatstgenoemde bestudeerde ik de  $\lambda$ -calculus (ook wel Combinatorische Logica geheten). Dit gebeurde in een seminarium met als verdere deelnemers Jan Bergstra en Henri Volken; de doelstelling was niet alleen receptief  $\lambda$ -calculus te beoefenen, maar met ons vieren ook actief onderzoek te doen. Dat heeft geleid tot enkele publicaties, waarop ik samen met Jan Bergstra na mijn doctoraalexamen (juni 1975) ben doorgedaan, toen ik inmiddels een vierjarige promotie-aanstelling gekregen had (half bij de Subfaculteit Wiskunde en half bij de Centrale Interfaculteit van de R.U. Utrecht).

Na dit gezamenlijke werk ben ik vanaf 1976 doorgedaan op hetzelfde onderzoeksgebied: de syntactische kant van  $\lambda$ -calculus en Combinatorische Logica, wat geleid heeft tot het onderhavige proefschrift en een publicatie in het aanstaande Festschrift voor de nestor van de Combinatorische Logica, H.B. Curry.

Vanaf augustus 1979 ben ik in tijdelijke betrekking bij de Stichting Opleiding Leraren te Utrecht.

Jan Willem Klop.

